

# Standard

## STANDARD MAG BALLAST (1) F20T12 PH 120V

Available for many fluorescent lamp types sold today, including Preheat, Rapid Start, 2-pin CFL, Slimline, High Output, Very High Output and Circline. Magnetic ballasts can be used in any application where these lamps are used.

### Product data

General Information		Rated Lamp Watts	
Lamp Type	F20T12		20W W
Number of Lamps	1 piece/unit	<b>Wiring</b>	
Lamp Footage	-	Wire Striplength	0.50/0.375 mm
Ballast Type	Magnetic Fluorescent	Lamp Connection	Series
Base Model	LC1420C	Wire Length By Color	See data sheet
Suitable For Outdoor Use	Yes	Wire Gauge (Nom)	18AWG mm
Automatic Restart	Yes	Wire Type	Solid
<b>Operating and Electrical</b>		Remote Wiring Configuration Allowed	Yes
Input Voltage	120 V	Tandem Wiring Configuration Allowed	No
Input Frequency	60 Hz	Through Wiring Configuration Allowed	No
Max THD	10 %	Max Ballast-Lamp Distance Remote Wiring	30'
Power (Rated) (Nom)	20 W	Max Ballast-Lamp Distance Tandem Wiring	-
Starting Method	Preheat	Max Ballast-Lamp Distance Through Wiring	-
Lamp Current Crest Factor (Nom)	1.5	<b>Mechanical and Housing</b>	
Ignition Time (Nom)	1 s	Housing Material	Metal
Inp. Current (Open Circuit)	0	Housing	C2
Input Current (Starting)	0.36	Housing Dimensions	1.06" x 1.59" x 1.81"
Ballast Factor (Nom)	0.93	<b>Approval and Application</b>	
Power Factor (Nom)	0.52	EMC Immunity Standard	FCC Non-Consumer
Input Current (Operating) (Nom)	0.33 A	Sound Rating	A
Input Power (Nom)	21 W		

## Standard

UL Recognized	No
<b>Product Data</b>	
Order product name	STANDARD LC1420CI
EAN/UPC - Product	781087101308
Order code	LC1420CI
Local order code	196584

Numerator - Quantity Per Pack	1
Numerator - Packs per outer box	12
Material Nr. (12NC)	913710305701
Net Weight (Piece)	0.350 kg

## Dimensional drawing

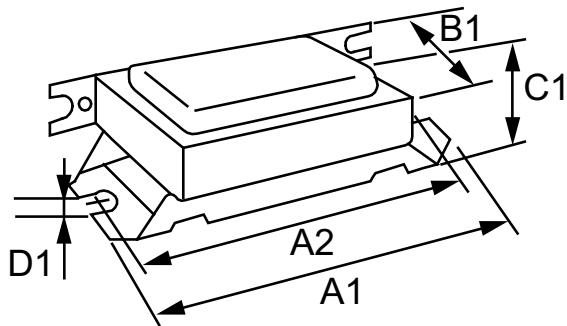

MAG BALLAST (1) F20T12 PH 120V

Product	A1	A2	B1	C1	D1
---------	----	----	----	----	----

