

# Bulletin 931 Signal Conditioners



Technical Data



LISTEN.  
THINK.  
SOLVE.®

**Introduction to Signal Conditioners . . . . .4**  
**Catalog Number Explanation . . . . .6**  
**Product Overview . . . . .7**  
**Product Selection . . . . .11**  
**Accessories . . . . .37**  
**Dimensions . . . . .38**  
**Glossary . . . . .41**

**Product Line Overview**

			
<b>Bulletin</b>	<b>931-H</b>	<b>931-S</b>	<b>931-U</b>
<b>Type</b>	<b>High-Density Signal Conditioners</b>	<b>Standard Signal Conditioners</b>	<b>Universal Signal Conditioners</b>
<b>Features</b>	<ul style="list-style-type: none"> <li>• Cost-effective analog signal conditioning in a high-density (6 mm wide) housing</li> </ul>	<ul style="list-style-type: none"> <li>• Provide solutions for a wide variety of analog signals</li> <li>• Available in compact sizes ranging from 12.5 mm to 22.5 mm wide.</li> </ul>	<ul style="list-style-type: none"> <li>• Programmable— allowing the devices to be used on a wide variety of analog signals</li> <li>• Two models are available, one housing is 12.5 mm wide, the other is 45 mm wide</li> </ul>
<b>Product Selection by Function Type</b>			
<b>Current/Voltage</b>	<b>Page 11</b>	<b>Page 14</b>	<b>Page 35</b>
<b>RTD</b>	<b>Page 21</b>	<b>Page 23</b>	<b>Page 35</b>
<b>Thermocouple</b>	<b>Page 24</b>	<b>Page 26</b>	<b>Page 35</b>
<b>Line-Monitoring</b>	—	<b>Page 27</b>	—
<b>Bridge</b>	—	<b>Page 32</b>	—
<b>Frequency</b>	—	<b>Page 33</b>	<b>Page 35</b>
<b>HART</b>	<b>Page 34</b>	—	—

### Analog Signal Conditioner Functionality

Analog Signal Conditioners are designed for use with Rockwell Automation I/O systems to provide reduced installation and maintenance costs in process applications. The products are available with two way isolation (between input and output) or three way isolation (between input, output and power).

- Isolation of analog measurement and control signals with 2 way isolation (between input and output) or 3 way isolation (between input, output and power).
- Conversion of analog signals from voltage to current. (i.e. 0...10V to 4...20 mA, etc.)
- Amplification, linearization, and transmission of low level sensor signals (i.e., mV signals from thermocouples, etc.).
- Transmission of analog signals over long distances
- Provides local display using a splitter or remote status indications and alarms via relay contact closures based on the analog signals.



### Typical Applications

Analog Signal Conditioners are used wherever temperature, pressure, level, flow, weight, speed, etc. is measured and controlled as part of a continuous or batch production process. Analog Signal Conditioners help to prevent these measurements from being degraded on their way from the field to the control room by providing protection from external influences or problems that result from the installation methods used. Typical industries include power plants, steel production, water and wastewater plants, oil and gas production, and chemical processing.



### Integrated Architecture

#### Scalable . . . Multi-disciplined . . . Information Enabled

The Rockwell Automation Integrated Architecture™ system improves your productivity and reduces total cost of ownership by providing unparalleled functionality, flexibility and scalability. Using sophisticated control, networking, visualization and information technologies, the Integrated Architecture addresses a full range of control and information needs for discrete, motion, process and batch control, drive control, and safety applications.

### Analog Signal Processing

Analog signals involve the measurement of constantly changing physical operating characteristics which come in many different forms, the most common of which are temperature and pressure. These signals are often found in processes that involve harsh industrial environments or are exposed to the elements. Such environmental conditions can significantly affect the quality of the transmitted signal and are also constantly changing themselves. Additionally, such industrial processes often require that these signals are able to be accurately transmitted over long distances. For these and a variety of other reasons, analog signal conditioning is often required between the measuring instrumentation and the control system. Analog signal conditioning is a long established practice in many process industries such as oil and gas processing, pharmaceutical and chemicals industries and standardized electrical signals are normally used. Currents of 0...20 mA or 4...20 mA and voltages of 0...10 V DC are the most often specified by controls engineers.

## Bulletin 931 Signal Conditioners Product Range

Rockwell Automation offers a wide range of products to condition analog signals according to industry standards. The Bulletin 931 Analog Signal Conditioners also provide the necessary isolation of the field measurement device from the controller as well as from any external power supplies. Such isolation prevents interference that can occur due to ground loops or common mode noise. The wide range of Allen-Bradley Bulletin 931 Analog Signal Conditioners completely covers the functions involved in analog signal conversion, isolation, and monitoring. The product range addresses nearly all applications in industrial measuring technology and safeguards the elementary functions between field signals and control systems. The products are easily mounted on 35 mm DIN rail and come in standard electronic housings with widths of 6, 12.5, 17.5, 22.5, or 45 mm.

### Analog Signal Conditioners

#### Problem solvers for process automation.

Given the wide variety of analog I/O available with today's modern industrial and process control systems, some may question why Analog Signal Conditioners are used. Here are a few examples of why an Analog Signal Conditioner might be desirable or required in an installation.

- **Local Alarm/Indication**

Many analog signals are passed to local indicators and alarms, which then need to be isolated from each other.

- **Long Distance Transmission**

Instead of running expensive cable to the control system (e.g., thermocouples for temperature), Analog Signal Conditioners can isolate and convert to a high level signal that is easier to transmit (e.g., 4...20 mA).

- **Non-Isolated Analog I/O**

If the existing control system does not provide isolated analog inputs, a separate Analog Signal Conditioner will often be used to provide signal isolation when required e.g., if the control system needs to be protected from electrical noise pulses on its analog inputs.

- **Isolation of the Power Source**

Where the control system cannot provide power for the sensor / transmitter, it is often convenient to provide isolation of the power source using an Analog Signal Conditioner.

- **Local Display and Linearization**

When a dedicated local display is required, the analog signal can be split using an Analog Signal Conditioner. For example, where a liquid volume indicator is needed for filling a bulk storage tank, but the measurement is level (level to volume conversion depends on the shape of the tank).

- **The remaining I/O available in an existing system does not provide for the input type of the sensor required.**

Example: The remaining I/O in the control system requires a 4...20mA analog inputs and the sensors provide less common signals – e.g., 0...20mV, 2...10V, 0...10V , 0...1mA, 4...12 mA, 0...5 A (AC), etc.



Standard



High-Density



Universal

**Analog Signal Processing**

Analog signals involve the measurement of constantly changing physical operating characteristics which come in many different forms, the most common of which are temperature and pressure. These signals are often found in processes that involve harsh industrial environments or are exposed to the elements. Such environmental conditions can significantly affect the quality of the transmitted signal and are also constantly changing themselves. Additionally, such industrial processes often require that these signals are able to be accurately transmitted over long distances.

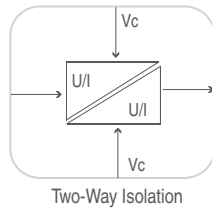

Two-Way Isolation

Analog signal conditioners with 2-way isolation separate the input and output signals from each other electrically and decouple the measuring circuits. Potential differences caused by long line lengths and common reference points are eliminated. The electrical separation also protects against irreparable damage caused by over voltages as well as inductive and capacitive interference.

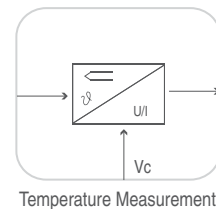

Temperature Measurement  
Thermocouples

Analog signal conditioners for connecting conventional thermocouples are fitted with cold trap compensation as standard. These devices amplify and linearize the voltage signal provided by the thermocouple. This guarantees accurate analog signal conditioning while eliminating sources of interference or error.

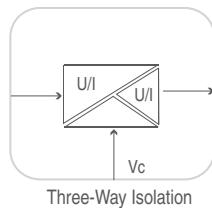

Three-Way Isolation

Analog signal conditioners with three-way isolation separate the supply voltage from the input and output circuits as well and enables the analog circuit to operate with just one operating voltage.

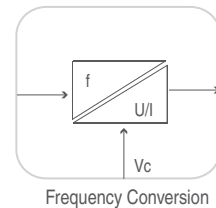

Frequency Conversion

Analog signal conditioners are available to convert frequencies into standard analog signals. Downstream controls can therefore directly process pulse strings for measuring rpm or speed.

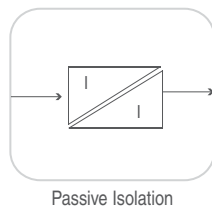

Passive Isolation

Analog signal conditioners with passive isolation offer an additional advantage in that they do not require an additional voltage supply. The power supply to the analog signal conditioner can be provided either by the input or output circuit. This current loop feed is characterized by very low power consumption.

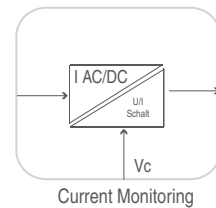

Current Monitoring

Analog signal conditioners are available for current monitoring for currents up to 60A AC or DC. These devices cause a switched output to be triggered by currents above or below the set value and may also provide analog outputs for continuous monitoring of the load current.

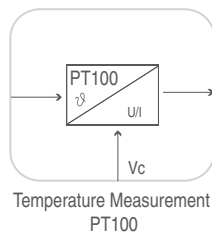

Temperature Measurement  
PT100

A number of analog signal conditioners are available for temperature measurements. For example, PT100 signals in 2-, 3- and 4-wire systems are converted into standard 0...20 mA, 4...20 mA and 0...10V signals.

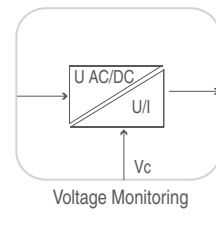

Voltage Monitoring

Analog signal conditioners are available for voltage monitoring of both AC and DC voltages. Voltage fluctuations due to switching processes or overload conditions can be detected for voltages above or below the user-defined switching threshold.

**Catalog Number Explanation**

**Note:** Examples given in this section are for reference purposes. This basic explanation should not be used for product selection; some combinations may not produce a valid catalog number.

931 **S** - **A1** **A1** **N** - **IP** **N**  
*a* *b* *c* *d* *e* *f*

*a*

Code	Description
H	High-density
S	Standard
U	Universal

*b*

Input Type	
Code	Description
Current	
A1	0(4)...20 mA
A2	4...20 mA
A3	0...1 A, 0...5 A or 0...10 A AC
A4	0...20 A, 0...25 A or 0...30 A AC/DC
Bridge	
B1	-500 mV...+500 mV
Voltage or Current	
C1	0...5V or 0...1V DC
	0...20 mA or 4...20 mA
C2	0...10V DC
	0...20 mA or 4...20mA
C3	0...10V DC
	0...22 mA
C4	±20mV...±200V
	±0.1 mA...100 mA
C9	Universal Inputs
Frequency	
F1	2-,3-wire PNP/NPN, namar initiator, push/pull step
Potentiometer	
P1	PT 100/2/3/4-Conductor or Ni 100/2/3/4-Conductor
P2	PT 100/2/3-Conductor
P3	PT 100/2/3/4-Conductor
Thermocouple	
T1	Type J
T2	Type K
T9	Types K,J,T,E,N,R,S,B
Voltage	
V1	24...70V, 70...140V, 140...210V or 210...260V AC/DC

*c*

Output Type	
Code	Description
Current	
A1	0(4)...20 mA
A2	4...20 mA
A5	(2) 4...20 mA
Voltage or Current	
C1	0...5V or 0...1 VDC
	0...20 mA or 4...20 mA
C2	0...10V DC
	0...20 mA or 4...20mA
C3	0...10V DC
	0...22mA
C5	0...±10V
	0...±20 mA
C6	0...5V, 5...0V DC or 10...0V, 0...10V DC
	0...20 mA, 20...0 mA or 4...20 mA, 20...4 mA
C7	0...±10V
	0...±20 mA
R1	3 A relay contact closure digital output

*d*

Configuration Setting	
Code	Description
N	Non-configurable
D	DIP Switch
J	Jumper
C	Computer

*e*

Power Type	
Code	Description
IP	Input Loop Power
OP	Output Loop Power
BC	Aux AC or DC Power
DC	DC Aux Power
MC	from the Measuring Circuit

*f*

Miscellaneous	
Code	Description
1	One Channel
2	Two Channels
Hall	Hall Effect Sensor
Hart	Hart Communication Protocol
Cable	Cable
1R	One Relay
2R	Two Relays

**Bulletin 931**  
**Signal Conditioners**  
**Product Overview**

**Bulletin 931H - High-Density Series**

The modules in the High-Density series provide cost-effective analog signal conditioning in a very small package.

- Extreme high-density mounting (6 mm wide modules)
- Provide isolation and conversion solutions for a variety of signals
  - Current
  - Voltage
  - Temperature (thermocouples and RTDs)
- The DIP switches can be accessed from outside the housing
- Capability to jumper incoming power from unit to unit using standard Bulletin 1492 terminal block jumpers on most Bulletin 931H devices
- Wiring diagrams printed on outside of housing for ease of use in commissioning and maintenance activities
- End barrier is required for Cat Nos: 931H-P2A2N-OP and 931H-A1A1N-IP.



**Power Connections**

Standard Bulletin 1492 jumpers can be used to connect units to the same Bulletin 1606 power supply. These jumpers provide a fast and easy way to provide power to a series of Bulletin 931 analog signal conditioners mounted together on a DIN Rail.

**DIP Switch Programmable**

The Bulletin 931H products are easily programmable with the DIP switches located on the outside of the housing along with the printed tables of the possible input and output combinations.

**High-Density Housing**

The Bulletin 931H product line offers a wide range of functionality in the high-density 6mm housing.

**Wiring Diagrams**

Bulletin 931H products have the wiring diagrams printed on the outside of the housing to reduce complexity during installation and maintenance.



**Cat. No. 931H-P2A2N-OP**



**Cat. No. 931H-A1A1N-1P**



**End Barrier, Cat. No. 931H-EB1**

## Bulletin 931S - Standard Series

The Bulletin 931S Standard Series of analog signal conditioners provide solutions for a wide variety of analog signals. They are available in compact sizes ranging from 12.5... 22.5 mm in width.

- Provide isolation and conversion solutions for a wide variety of signals:
  - Current
  - Voltage
  - Temperature (thermocouples and RTDs)
  - Frequency
  - Load Cells (bridge transducers)
  - Potentiometers
- Removable, plug-in terminal blocks are coded to eliminate wiring errors.
- The printed circuit board can be removed and re-installed without tools providing ease-of-use when accessing the internal DIP switches.
- Capability to jumper incoming power from unit to unit using standard Bulletin 1492 terminal block jumpers on some 931S devices.
- Jumper settings printed on outside of housing for ease-of-use in commissioning and maintenance activities.

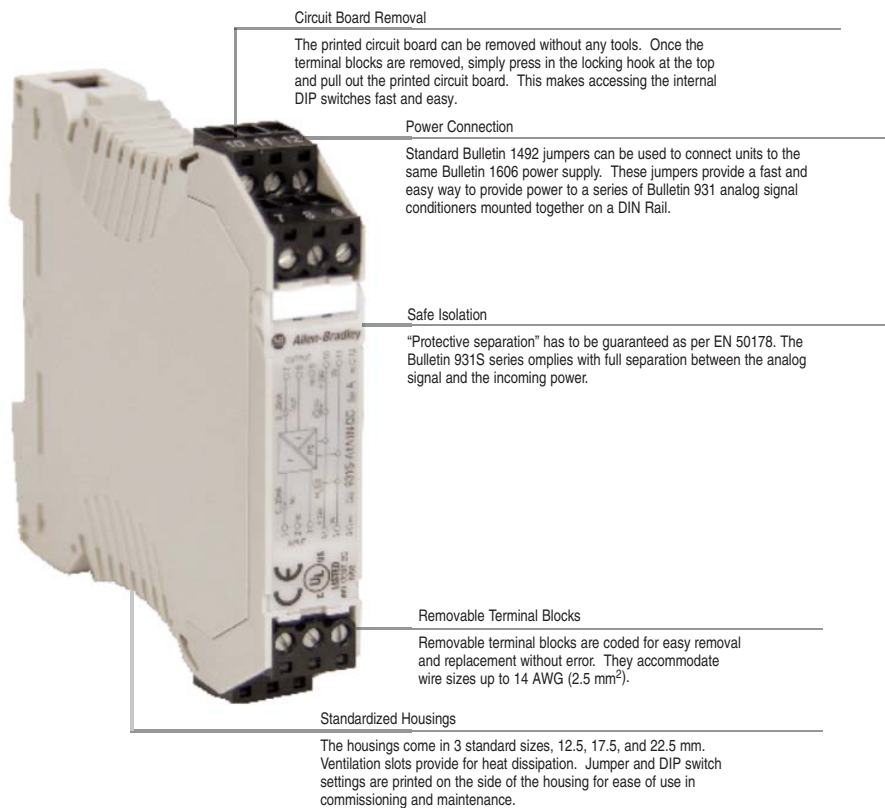



**Bulletin 931**  
**Signal Conditioners**  
**Product Overview**

**Bulletin 931U- Universal Series**

The Bulletin 931U Universal Series of analog signal conditioners are programmable, allowing the devices to be used on a wide variety of analog signals. Two models are available, one in a 12.5mm wide housing and one in a 45mm wide housing. Both are programmable using software.

- Provide isolation and conversion solutions for a wide variety of signals:
  - Current
  - Voltage
  - Temperature (thermocouples and RTDs)
  - Potentiometers
  - AC and DC current monitoring
- Removable, plug-in terminal blocks are coded to eliminate wiring errors.
- Programmable using software, which is bundled with the programming cable - Cat. No. 931U-CABLE.



**Bulletin 931U Programming Software**



**Universal Inputs**

The Bulletin 931U products can input a wide range of analog signals (current, voltage, thermocouple, RTD, resistance, frequency, etc).

**Software Programmable**

The Bulletin 931-U products are programmed using the software and cable included in 931U-CABLE product. The cable connects from the front of the signal conditioner unit to your computer's USB port.

**Certifications**

Allen-Bradley's Bulletin 931U product line has been certified to global certifications. These products not only have cULus – Class 1, Div. 2, Groups A, B, C, and D ratings, but also the European CE and ATEX markings.



**Analog/Digital Outputs**

The Bulletin 931U products have the capability to output both analog and digital signals. Using the programming software you can have the unit output a current or voltage signal and also dual digital signals from two CO contacts.

**Passive Isolator, 1 Channel**

- Passive isolator for electrical isolation of standard 0...20 mA or 4...20 mA signals
- No need for auxiliary power supply
- Low power consumption

**931H-A1A1N-IP**

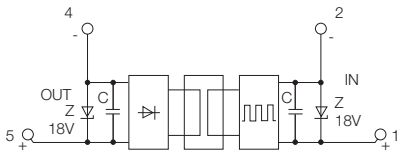
					
Specifications	<b>Passive Isolator, 1-Channel</b>				
Wiring Diagram					
Standards Compliance	UL 508, CSA C22.2 No. 142-M1987, CSA C22.2 No. 0-10, CSA C22.2 No. 14-10, EN 50178:1997, EN 61000-6-1:2007, EN 61000-6-2: 2005, EN 61000-6-3:2007, EN 61000-6-4:2007				
Certifications	cURus (NRAQ2/8.E113724), CSA, CE				
<b>Input Ratings</b>					
Current	0(4)...20 mA				
Max Voltage	15V				
Max Current	50 mA				
Pick-up Current	< 100 $\mu$ A				
Voltage Drop	2.5...3 V at 20 mA				
Input	Passive				
<b>Output Ratings</b>					
Current	0(4)...20 mA				
Voltage	—				
Load Impedance (voltage/current)	— / $\leq$ 500 $\Omega$				
Step Response Time	approx. 1.2 ms				
Accuracy	< 0.1% of final value				
Temperature Coefficient	$\leq$ 50 ppm/K of measurement value at 0 $\Omega$ load resistance				
Residual Ripple	< 10 mV				
Cut-off Frequency	approx. 200 kHz				
Output	Active				
<b>General Specifications</b>					
Power Type	Input Loop Powered				
Operating Temperature	-25 $^{\circ}$ C...+60 $^{\circ}$ C				
Storage Temperature	-40 $^{\circ}$ C...+85 $^{\circ}$ C				
Isolation Voltage Input - Output	500V <sub>eff</sub>				
Rated Isolation Voltage	50V				
Connection Type	Tension clamp				
L x W x H (mm)	91 x 6 x 63.2				
<b>Signal Conditioner</b>	<table border="1" style="width: 100%; border-collapse: collapse;"> <tr> <td style="text-align: center;">Cat. No.</td> <td style="text-align: center;">Pkg. Quantity</td> </tr> <tr> <td style="text-align: center;"><b>931H-A1A1N-IP</b></td> <td style="text-align: center;">1</td> </tr> </table>	Cat. No.	Pkg. Quantity	<b>931H-A1A1N-IP</b>	1
Cat. No.	Pkg. Quantity				
<b>931H-A1A1N-IP</b>	1				
End Barrier (required)	<b>931H-EB1</b> 10				

# Signal Conditioners

## Current/Voltage Signal Conditioners

### Active Isolator, 3-Way

- Two conductor system
- Three port isolation
- Power supply can be cross-connected using center jumpers

### 931H-A2A2N-DC

		
Specifications	<b>Active Isolator, 3-Way</b>	
Wiring Diagram		
Standards Compliance	UL 508, CSA C22.2 No. 0-10, CSA C22.2 No. 14-10, EN 50178:1997, EN 61000-6-1:2007, EN 61000-6-2: 2005, EN 61000-6-3:2007, EN 61000-6-4:2007	
Certifications	cURus (NMTR2/8.E56639), CE	
<b>Input Ratings</b>		
Current	4...20mA	
Sensor	2-conductor	
Supply Voltage	16.5V / constant for 3...22 mA	
Input	Active	
<b>Output Ratings</b>		
Current	4...20 mA	
Load Impedance (voltage/current)	$\geq 10 \text{ k}\Omega / \leq 500 \Omega$	
Accuracy	$< 0.1 \%$	
Temperature Coefficient	$\leq 50 \text{ ppm/K}$	
Step Response Time	$\leq 2\text{ms}$	
Offset Current	$< 30 \mu\text{A}$	
Residual Ripple	$< 10\text{mV}$	
Output	Active	
<b>General Specifications</b>		
Supply Voltage	24V DC $\pm 15\%$	
Power Consumption	approx. 1 W	
Current Carrying Capacity of Cross Connect	$\leq 2 \text{ A}$	
Operating Temperature	0 °C...+55 °C	
Storage Temperature	-25 °C...+85 °C	
Rated Insulation Voltage	300V	
Isolation Voltage Input - Output	1.5kV <sub>eff</sub>	
Surge Category	II	
Pollution Severity	2	
Connection Type	Screw	
L x W x H (mm)	88 x 6.1 x 97.8	
<b>Signal Conditioner</b>	Cat. No.	Pkg. Quantity
	931H-A2A2N-DC	1

**Active Converter, 3-Way**

- Three way isolation
- Calibrated change over via DIP switch
- Power supply can be cross-connected using plug-in jumpers
- Low power loss

**931H-C2C2D-DC**

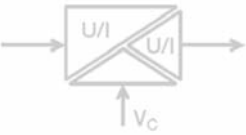
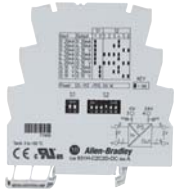
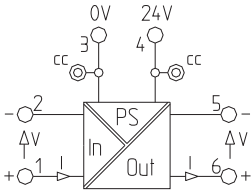
					
Specifications	<b>Active Converter, 3 Way</b>				
Wiring Diagram					
Standards Compliance	UL 508, CSA C22.2 No. 0-10, CSA C22.2 No. 14-10, EN 50178:1997, EN 61000-6-1:2007, EN 61000-6-2: 2005, EN 61000-6-3:2007, EN 61000-6-4:2007				
Certifications	cURus (NMTR2/8.E56639), CE				
<b>Input Ratings</b>					
Voltage	0...10V				
Max. Voltage	30V				
Current	0...20 mA / 4...20 mA				
Max. Current	< 100 mA				
Input Resistance (voltage/current)	100 kΩ / ≤ 5 Ω				
Voltage Drop	< 0.1V at I <sub>IN</sub> = 20 mA (current input)				
Input	Passive				
<b>Output Ratings</b>					
Voltage	0...10V				
Current	0...20 mA / 4...20 mA				
Load Impedance (voltage/current)	≥ 10 kΩ / ≤ 500 Ω				
Step Response Time	10 ms				
Accuracy	< 0.5% of final value				
Temperature Coefficient	≤ 150 ppm/K of final value				
Cut-off Frequency (-3 dB)	> 100 Hz				
Output	Active				
<b>General Specifications</b>					
Supply Voltage	24V DC ± 15%				
Power Consumption	approx. 0.6 W				
Current Carrying Capacity of Cross Connect	≤ 2 A				
Operating Temperature	0 °C...+55 °C				
Storage Temperature	-25 °C...+85 °C				
Default Settings	0...20 mA / 0...20 mA				
Rated Insulation Voltage	50V				
Isolation Voltage Input - Output	500V <sub>eff</sub> / 1 s				
Surge Category	II				
Pollution Severity	2				
L x W x H (mm)	88 x 6.1 x 97.8				
Signal Conditioner	<table border="1"> <tr> <td>Cat. No.</td> <td>Pkg. Quantity</td> </tr> <tr> <td>931H-C2C2D-DC</td> <td>1</td> </tr> </table>	Cat. No.	Pkg. Quantity	931H-C2C2D-DC	1
Cat. No.	Pkg. Quantity				
931H-C2C2D-DC	1				

**Setting options/switch position**

Input	Output	Switch							
		S1		S2					
		1	2	1	2	3	4	5	6
0 ... 20 mA	0 ... 20 mA	■	□	□	□	□	■	□	□
0 ... 20 mA	4 ... 20 mA	■	□	□	□	■	■	□	□
0 ... 20 mA	0 ... 10 V	■	□	□	□	□	□	■	■
4 ... 20 mA	0 ... 20 mA	■	■	■	■	□	□	□	□
4 ... 20 mA	4 ... 20 mA	■	□	□	□	□	□	□	□
4 ... 20 mA	0 ... 10 V	■	■	■	■	■	■	■	■
0 ... 10 V	0 ... 20 mA	□	■	□	□	□	■	□	□
0 ... 10 V	4 ... 20 mA	□	□	□	□	■	■	□	□
0 ... 10 V	0 ... 10 V	□	■	□	□	□	□	■	■

■ = on  
 □ = off

**Connection**

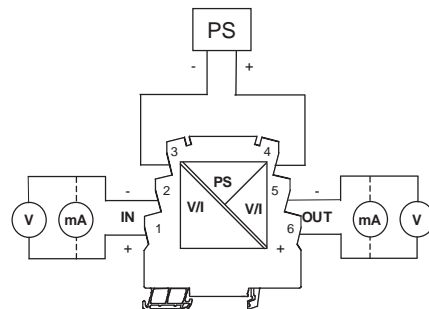



# Signal Conditioners

## Current/Voltage Signal Conditioners

### Active Converter, 3-Way

- Signal conversion
- Electrical isolation between input/output signal and power supply
- Power supply can be cross-connected using center jumpers

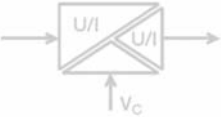
### 931S-A1A1N-DC

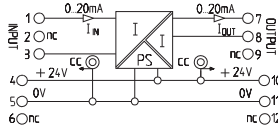

		
Specifications	<b>Active Isolator, 3-Way</b>	
Wiring Diagram		
Standards Compliance	UL 508, CSA C22.2 No. 142-M1987, EN 50178:1997, EN 61000-6-1:2007, EN 61000-6-2: 2005, EN 61000-6-4:2007	
Certifications	cULus (NRAQ/7.E113724), CE	
<b>Input Ratings</b>		
Current	0(4)...20 mA	
Max Current	25 mA	
Input	Passive	
<b>Output Ratings</b>		
Current	0(4)...20 mA	
Load Impedance (voltage/current)	— / $\leq 600 \Omega$	
Step Response Time	$\leq 45$ ms	
Accuracy	0.2%	
Temperature Coefficient	$\leq 250$ ppm/K of final value	
Cut-off Frequency (-3 dB)	10 Hz	
Output	Active	
<b>General Specifications</b>		
Supply Voltage	24V DC $\pm 25\%$	
Power Consumption	$< 1.5$ W at $I_{OUT} = 20$ mA	
Current-Carrying Capacity of Cross-Connect	$\leq 2$ A	
Operating Temperature	0 °C...+55 °C	
Storage Temperature	-20 °C...+85 °C	
Rated Insulation Voltage	300V	
Impulse Withstand Voltage	4kV	
Isolation Voltage Input/Output	2kV <sub>eff</sub> /5 s	
Surge Category	III	
Pollution Severity	2	
Connection Type	Screw	
L x W x D (mm)	92.4 x 17.5 x 112.4	
Signal Conditioner	Cat. No.	Pkg. Quantity
	931S-A1A1N-DC	1

**Passive Isolator**

- Reliable isolation
- Very low power consumption

**931S-A1A1N-IP1**

**931S-A1A1N-IP2**

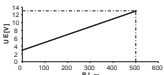
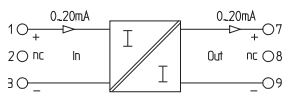
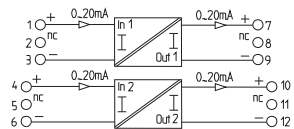
				
				
<b>Specifications</b>	<b>Passive Isolator, 1-channel</b>	<b>Passive Isolator, 2-channel</b>		
Wiring Diagram				
Standards Compliance	UL 508, UL 1604, CSA C22.2 No. 142-M1987, CSA C22.2 No. 213-1987, EN 50178:1997, EN 61000-6-1:2007, EN 61000-6-2: 2005, EN 61000-6-3:2007, EN 61000-6-4:2007	UL 508, UL 1604, CSA C22.2 No. 142-M1987, CSA C22.2 No. 213-1987, EN 50178:1997, EN 61000-6-1:2007, EN 61000-6-2: 2005, EN 61000-6-3:2007, EN 61000-6-4:2007		
Certifications	cULus (Class 1, Div. 2, Groups A, B, C and D, NRAG/7.E10314), CSA, CE	cULus (Class 1, Div. 2, Groups A, B, C and D, NRAG/7.E10314), CE		
<b>Input Ratings</b>				
Voltage	—	—		
Current	0(4)...20 mA	0(4)...20 mA		
Pick-up Current	<100 $\mu$ A	<100 $\mu$ A		
Voltage Drop	approx. 3V at $R_L = 0 \Omega$ , approx. 13V at $R_L = 500 \Omega$ ( $I_{IN} = 20\text{mA}$ )	approx. 3V at $R_L = 0 \Omega$ , approx. 13V at $R_L = 500 \Omega$ ( $I_{IN} = 20\text{mA}$ )		
Max Voltage	18V	18V		
Max Current	50 mA	50 mA		
Input	Passive	Passive		
<b>Output Ratings</b>				
Voltage	—	—		
Current	0(4)...20 mA	0(4)...20 mA		
Load Impedance (voltage/current)	— / $\leq 500 \Omega$	— / $\leq 500 \Omega$		
Temperature Coefficient	$\leq 50$ ppm/K of final value	$\leq 50$ ppm/K of final value		
Residual Ripple	<20 mV	<20 mV		
Step Response Time	4.5 ms	4.5 ms		
Accuracy	< 0.1% of final value	< 0.1% of final value		
Output	Active	Active		
<b>General Specifications</b>				
Power Type	Input Loop Powered	Input Loop Powered		
Operating Temperature	-25 °C...+70 °C	-25 °C...+70 °C		
Storage Temperature	-40 °C...+80 °C	-40 °C...+80 °C		
Rated Insulation Voltage	300V	300V		
Impulse Withstand Voltage	6kV	6kV		
Isolation Voltage Input - Output	4kV/1 s	4kV/1 s		
Surge Category	III	III		
Pollution Severity	2	2		
Connection Type	Screw	Screw		
L x W x D (mm)	92.4 x 17.5 x 112.4	92.4 x 17.5 x 112.4		
<b>Signal Conditioner</b>	Cat. No. <b>931S-A1A1N-IP1</b>	Pkg. Quantity <b>1</b>	Cat. No. <b>931S-A1A1N-IP2</b>	Pkg. Quantity <b>1</b>



# Signal Conditioners

## Current/Voltage Signal Conditioners

### Active Isolator

- Signal conversion
- Electrical isolation between input and output signals
- Power supply can be cross-connected using center jumpers

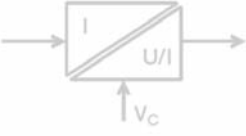

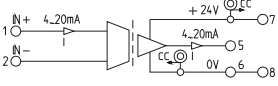
#### 931S-A2A2N-DC

		
Specifications	<b>Active Isolator</b>	
Wiring Diagram		
Standards Compliance	UL 508, UL 1604, CSA C22.2 No. 142-M1987, CSA C22.2 No. 213-1987, EN 50178:1997, EN 61000-6-1:2007, EN 61000-6-2:2005, EN 61000-6-3:2007, EN 61000-6-4:2007	
Certifications	cULus (Class 1, Div. 2, Groups A, B, C and D, NRAG/7.E10314), CE	
<b>Input Ratings</b>		
Current	4...20 mA	
Max Current	25 mA	
Max Voltage	7V	
Input	Passive	
<b>Output Ratings</b>		
Current	4...20 mA	
Load Impedance (voltage/current)	— \ ≤ 500 Ω	
Accuracy	± 0.2% of final value	
Temperature Coefficient	≤ 250 ppm/K	
Step Response Time	< 30 ms	
Cut-off Frequency (-3 dB)	≥ 15 Hz	
Output	Active	
<b>General Specifications</b>		
Supply Voltage	24V DC ± 20%	
Current Consumption	<32 mA at I=20 mA	
Current Carrying Capacity of Cross-Connect	≤ 2 A	
Operating Temperature	0 °C...+55 °C	
Storage Temperature	-20 °C...+85 °C	
Rated Insulation Voltage	300V	
Impulse Withstand Voltage	4kV	
Isolation Voltage Input - Output	1.2kV <sub>eff</sub> /1 s	
Surge Category	III	
Pollution Severity	2	
Connection Type	Screw	
L x W x D (mm)	92.4 x 12.5 x 112.4	
Signal Conditioner	Cat. No.	Pkg. Quantity
	931S-A2A2N-DC	1

**Passive Isolator, Splitter**

- Electrical isolation
- Input and output current loop feed
- Very low power consumption
- No calibration necessary

**931S-A2A5N-OP**

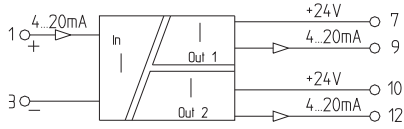
	
Specifications	<b>Passive Isolator, Splitter</b>
Wiring Diagram	
Standards Compliance	UL 508, UL 1604, UL 60079-15, CSA E60079-15:02, CSA C22.2 No. 213-1987, CSA C22.2 No. 142-M1987, EN 50178:1997, EN 60079-0:2006, EN 60079-15:2005, EN 61000-6-1:2007, EN 61000-6-2: 2005, EN 61000-6-3:2007, EN 61000-6-4:2007
Certifications	cULus (Class 1, Div. 2/Zone 2, Groups A, B, C and D, NRAG/7.E10314 and NWGD/7.E10314 ), CE, ATEX (Class 1, Zone 2, Demko 09ATEX 0929065X)

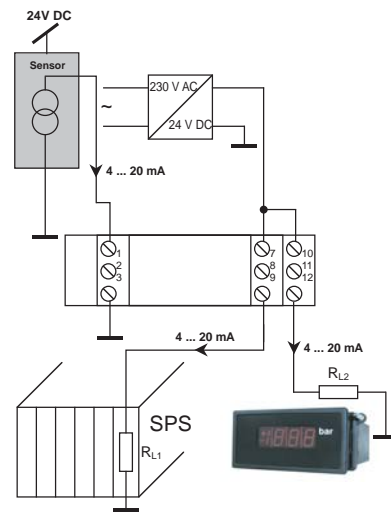

Input Ratings					
Current	4...20 mA				
Max Current	40 mA				
Voltage Drop	3.8V				
Input	Passive				
Output Ratings					
Current	2 x 4...20 mA				
Output Signal Limit	approx. 31 mA				
Load Impedance (voltage/current)	— / $R_L = (U_B - 12 V) / 20 \text{ mA}$ e.g. 600 $\Omega$ at 24 V				
Accuracy	Typical 0.1%, max. 0.2%				
Temperature Coefficient	$\leq 150 \text{ ppm/K}$				
Step Response Time	< 20 ms				
Cut-off Frequency (-3 dB)	30 Hz				
Output	Passive				
General Specifications					
Supply Voltage	min. 12V DC, max. 30V DC				
Power Type	Output Loop Powered				
Operating Temperature	0 °C...+55 °C				
Storage Temperature	-20 °C...+85 °C				
Rated Insulation Voltage	300V				
Impulse Withstand Voltage	4kV				
Isolation Voltage Input - Output	4kV <sub>eff</sub> /5s				
Surge Category	III				
Pollution Severity	2				
Connection Type	Screw				
L x W x D (mm)	92.4 x 17.5 x 112.4				
Signal Conditioner	<table border="1" style="width: 100%; border-collapse: collapse;"> <tr> <td style="text-align: center;">Cat. No.</td> <td style="text-align: center;">Pkg. Quantity</td> </tr> <tr> <td style="text-align: center;">931S-A2A5N-OP</td> <td style="text-align: center;">1</td> </tr> </table>	Cat. No.	Pkg. Quantity	931S-A2A5N-OP	1
Cat. No.	Pkg. Quantity				
931S-A2A5N-OP	1				



### Passive Converter

- Electrical isolation
- Very low power consumption
- Input range selected via DIP switch
- No calibration necessary

### 931S-C1A2D-OP

Specifications	<i>Passive Converter</i>				
Wiring Diagram					
Standards Compliance	UL 508, CSA C22.2 No. 142-M1987, EN 50178:1997, EN 61000-6-1:2007, EN 61000-6-2: 2005, EN 61000-6-3:2007, EN 61000-6-4:2007				
Certifications	cULus (NRAQ/7.E113724), CE				
Input Ratings					
Voltage	0...5V / 0...10V				
Current	0...20 mA / 4...20 mA				
Max Voltage	30V DC				
Max Current	40 mA				
Input Resistance (voltage/current)	0...5V: 210 kΩ; 0...10V: 430 kΩ / 51 Ω				
Input	Passive				
Output Ratings					
Current	4...20 mA				
Output Signal Limit	approx. 24 mA				
Load Impedance (current)	$R_L = (U_B - 12 V) / 20 \text{ mA}$ e.g. 600 Ω at 24 V				
Accuracy	0.2% of measuring range final value				
Temperature Coefficient	≤ 150 ppm/K				
Residual Ripple	50 mV at 500 Ω				
Step Response Time	< 10 Hz: 80 ms; 100 Hz: 50 ms				
Cut-off Frequency (-3 dB)	< 10 Hz/ 100 Hz switchable				
Output	Passive				
General Specifications					
Supply Voltage	min. 12V DC, max. 30V DC				
Power Type	Output Loop Powered				
Operating Temperature	0 °C...+55 °C				
Storage Temperature	-20 °C...+85 °C				
Default Settings	0...20 mA, 10Hz				
Rated Insulation Voltage	300V				
Impulse Withstand Voltage	4 kV				
Isolation Voltage Input - Output	4 kV <sub>eff</sub> / 5 s				
Surge Category	III				
Pollution Severity	2				
Connection Type	Screw				
L x W x D (mm)	92.4 x 17.4 x 112.4				
Signal Conditioner	<table border="1" style="width: 100%;"> <tr> <th style="text-align: center;">Cat. No.</th> <th style="text-align: center;">Pkg. Quantity</th> </tr> <tr> <td style="text-align: center;"><b>931S-C1A2D-OP</b></td> <td style="text-align: center;">1</td> </tr> </table>	Cat. No.	Pkg. Quantity	<b>931S-C1A2D-OP</b>	1
Cat. No.	Pkg. Quantity				
<b>931S-C1A2D-OP</b>	1				

Setting options/switch position

Input	SW 1			
	1	2	3	4
0...20 mA	<input type="checkbox"/>	<input type="checkbox"/>	<input type="checkbox"/>	<input type="checkbox"/>
4...20 mA	<input checked="" type="checkbox"/>	<input type="checkbox"/>	<input type="checkbox"/>	<input type="checkbox"/>
0...5 V	<input checked="" type="checkbox"/>	<input checked="" type="checkbox"/>	<input checked="" type="checkbox"/>	<input type="checkbox"/>
0...10 V	<input type="checkbox"/>	<input checked="" type="checkbox"/>	<input type="checkbox"/>	<input type="checkbox"/>
Transmission frequency				
10 Hz	<input type="checkbox"/>	<input type="checkbox"/>	<input type="checkbox"/>	<input checked="" type="checkbox"/>
100 Hz	<input type="checkbox"/>	<input type="checkbox"/>	<input type="checkbox"/>	<input type="checkbox"/>

■ = on  
□ = off

Example of application

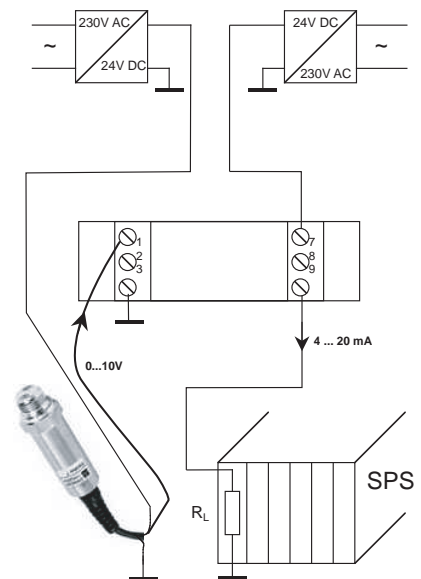

**Active Converter, 3-Way**

- Auxiliary power supply, 12...60V DC
- Current or voltage input configurable with DIP switch
- Input or output scaling

**931S-C3C3J-DC**



Specifications	<b>Active Converter, 3-Way</b>	
Standards Compliance	UL 61010B-1, CSA C22.2 No. 61010-1-2004, EN 50178:1997, EN 61000-6-1:2007, EN 61000-6-2: 2005, EN 61000-6-4:2007	
Certifications	cULus (PICQ/7.E345550), CE	
<b>Input Ratings</b>		
Type	Current or voltage input ★	
Input Signal Limits	0...22 mA / 0...10V	
Sensor Supply	20 mA @ 24V DC output	
Input Resistance (voltage/current)	1 MΩ / 100 Ω	
Input	Active or Passive ★	
<b>Output Ratings</b>		
Type	Current or voltage output ★	
Output Signal Limits	0...22 mA / 0...10V	
Accuracy	± 0.1% of end value	
Load Resistance (voltage/current)	≥ 500 Ω / ≤ 1 kΩ	
Step Response Time	< 220 ms (10...90%)	
Residual Ripple	< 20 mV	
Temperature Coefficient	≤ 0.05 % / °C	
Resolution	3.5 μA/1.76 mV per bit	
Output	Active	
<b>General Specifications</b>		
Supply Voltage	12...60V DC	
Power Consumption	< 2.5 W	
Operating Temperature	0 °C...+60 °C	
Storage Temperature	-25° C...+70° C	
Impulse Withstand Voltage	4kV (1.2/50 μs)	
Rated Voltage	300V <sub>eff</sub>	
Isolation Voltage Input-Output	2 kV	
Surge Category	III	
Pollution Severity	2	
L x W x D (mm)	92.4 x 12.5 x 112.4	
Connection Type	Screw	
<b>Signal Conditioner</b>	Cat. No.	Pkg. Quantity
	<b>931S-C3C3J-DC</b>	1

★ Configurable with jumpers

**Wiring possibility A (input passive)**

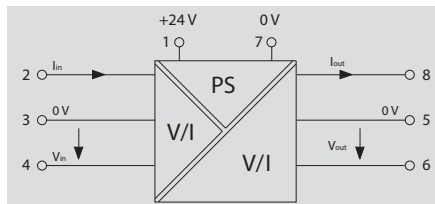

**Wiring possibility B (input active)**

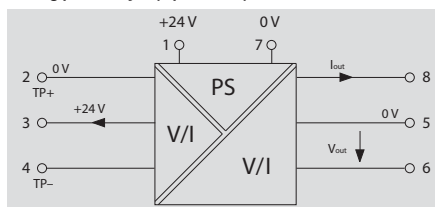

**Connections**

Terminal	Signal	
1	Signal +	Supply voltage
7	Signal -	
4	Signal +	Voltage input
3	Signal -	
2	Signal +	Current input
3	Signal -	
3	Signal +	Loop Powered Input
2	Signal -	
6	Signal +	Voltage output
5	Signal -	
8	Signal +	Current output
5	Signal -	

# Signal Conditioners

## Current/Voltage Signal Conditioners

### Active Converter, 3-Way

- Universally adjustable using DIP switch
- 931S Configurator to assist with DIP switch selection, download at [www.ab.com](http://www.ab.com)
- Voltage supply 20...230V AC/DC
- Low power loss
- Adjustable transmission frequency

### 931S-C4C5D-BC

Specifications	<b>Active Converter, 3 Way</b>	
Wiring Diagram		
Standards Compliance	UL 508, CSA C22.2 No. 142-M1987, EN 50178:1997, EN 61000-6-1:2007, EN 61000-6-2: 2005, EN 61000-6-3:2007, EN 61000-6-4:2007	
Certifications	cULus (NRAQ/7.E113724), CE	
<b>Input Ratings</b>		
Voltage	± 20mV...± 200V	
Current	± 0.1 mA...± 100 mA	
Input Resistance (voltage/current)	1 MΩ / < 5 mA: approx. 100 Ω; > 5 mA: approx. 5 Ω	
Input	Passive	
<b>Output Ratings</b>		
Voltage	0...±10V	
Current	0...±20 mA	
Load Impedance (voltage/current)	≥ 1 kΩ / ≤ 600 Ω	
Accuracy	< 0.1% of final value	
Temperature Coefficient	≤ 60 ppm/K end value	
Offset Current/Voltage	20 μA / 10 mV	
Step Response Time	1 ms/ 100 ms (switchable)	
Adjustment Range, Zero Point	± 25% of measuring range of chosen output range	
Adjustment Range, Amplification	0.33...3.30 x final value of selected output range	
Offset Potentiometer	100%, -50%, 0%, 50%, 100% of measuring range	
Cut-off Frequency (-3 dB)	> 10 kHz/ < 10 Hz	
Output	Active	
<b>General Specifications</b>		
Supply Voltage	22...230V AC/DC +10 %/ 48...62 Hz	
Power Consumption	approx. 1 W	
Operating Temperature	-10 °C...+70 °C	
Storage Temperature	-40 °C...+85 °C	
Default Settings	0...10V / 0...10V / 10Hz	
Rated Insulation Voltage	600V	
Impulse Withstand Voltage	5kV, 1.2/50 μs (IEC 255-4)	
Isolation Voltage Input - Output	4kV <sub>eff</sub>	
Surge Category	III	
Pollution Severity	2	
Connection Type	Screw	
L x W x D (mm)	92.4 x 12.5 x 112.4	
Signal Conditioner	Cat. No.	Pkg. Quantity
	931S-C4C5D-BC	1

### Switch position/setting options

Input	Switch							
	S1				S2			
Input range	1	2	3	4	1	2	3	4
0 ... ±60 mV	<input type="checkbox"/>	<input type="checkbox"/>	<input type="checkbox"/>	<input type="checkbox"/>	<input type="checkbox"/>	<input type="checkbox"/>	<input type="checkbox"/>	<input checked="" type="checkbox"/>
0 ... ±100 mV	<input checked="" type="checkbox"/>	<input type="checkbox"/>	<input type="checkbox"/>	<input type="checkbox"/>	<input type="checkbox"/>	<input type="checkbox"/>	<input type="checkbox"/>	<input checked="" type="checkbox"/>
0 ... ±150 mV	<input type="checkbox"/>	<input checked="" type="checkbox"/>	<input type="checkbox"/>	<input type="checkbox"/>	<input type="checkbox"/>	<input type="checkbox"/>	<input type="checkbox"/>	<input checked="" type="checkbox"/>
0 ... ±300 mV	<input checked="" type="checkbox"/>	<input type="checkbox"/>	<input type="checkbox"/>	<input type="checkbox"/>	<input type="checkbox"/>	<input type="checkbox"/>	<input type="checkbox"/>	<input checked="" type="checkbox"/>
0 ... ±500 mV	<input type="checkbox"/>	<input type="checkbox"/>	<input checked="" type="checkbox"/>	<input type="checkbox"/>	<input type="checkbox"/>	<input type="checkbox"/>	<input type="checkbox"/>	<input checked="" type="checkbox"/>
0 ... ±1 V	<input checked="" type="checkbox"/>	<input type="checkbox"/>	<input type="checkbox"/>	<input type="checkbox"/>	<input type="checkbox"/>	<input type="checkbox"/>	<input type="checkbox"/>	<input checked="" type="checkbox"/>
0 ... ±5 V	<input type="checkbox"/>	<input type="checkbox"/>	<input type="checkbox"/>	<input checked="" type="checkbox"/>	<input type="checkbox"/>	<input type="checkbox"/>	<input type="checkbox"/>	<input checked="" type="checkbox"/>
0 ... ±10 V	<input checked="" type="checkbox"/>	<input type="checkbox"/>	<input type="checkbox"/>	<input type="checkbox"/>	<input type="checkbox"/>	<input type="checkbox"/>	<input type="checkbox"/>	<input checked="" type="checkbox"/>
0 ... ±100 V	<input type="checkbox"/>	<input type="checkbox"/>	<input type="checkbox"/>	<input checked="" type="checkbox"/>	<input type="checkbox"/>	<input type="checkbox"/>	<input type="checkbox"/>	<input checked="" type="checkbox"/>
0 ... ± ~0.3 mA	<input checked="" type="checkbox"/>	<input type="checkbox"/>	<input type="checkbox"/>	<input type="checkbox"/>	<input checked="" type="checkbox"/>	<input type="checkbox"/>	<input type="checkbox"/>	<input checked="" type="checkbox"/>
0 ... ±1 mA	<input type="checkbox"/>	<input checked="" type="checkbox"/>	<input type="checkbox"/>	<input type="checkbox"/>	<input checked="" type="checkbox"/>	<input type="checkbox"/>	<input type="checkbox"/>	<input checked="" type="checkbox"/>
0 ... ±5 mA	<input checked="" type="checkbox"/>	<input type="checkbox"/>	<input type="checkbox"/>	<input type="checkbox"/>	<input type="checkbox"/>	<input type="checkbox"/>	<input type="checkbox"/>	<input checked="" type="checkbox"/>
0 ... ±10 mA	<input type="checkbox"/>	<input type="checkbox"/>	<input checked="" type="checkbox"/>	<input type="checkbox"/>	<input checked="" type="checkbox"/>	<input type="checkbox"/>	<input type="checkbox"/>	<input checked="" type="checkbox"/>
0 ... ±20 mA	<input checked="" type="checkbox"/>	<input type="checkbox"/>	<input type="checkbox"/>	<input type="checkbox"/>	<input checked="" type="checkbox"/>	<input type="checkbox"/>	<input type="checkbox"/>	<input checked="" type="checkbox"/>
0 ... ±50 mA	<input type="checkbox"/>	<input type="checkbox"/>	<input type="checkbox"/>	<input checked="" type="checkbox"/>	<input type="checkbox"/>	<input type="checkbox"/>	<input type="checkbox"/>	<input checked="" type="checkbox"/>
4 ... ±20 mA*	<input checked="" type="checkbox"/>	<input checked="" type="checkbox"/>	<input checked="" type="checkbox"/>	<input checked="" type="checkbox"/>	<input checked="" type="checkbox"/>	<input checked="" type="checkbox"/>	<input checked="" type="checkbox"/>	<input checked="" type="checkbox"/>

\*Offset conversion not calibrated

Switch S2		4
calibrated ranges		<input checked="" type="checkbox"/>
Span-pot. activated: input x 0.33 ... x 3.30		<input type="checkbox"/>

Output	Switch				
	S1			S3	
Output range	5	6	7	1	2
0 ... ±10 V	<input type="checkbox"/>	<input type="checkbox"/>	<input type="checkbox"/>	<input checked="" type="checkbox"/>	<input checked="" type="checkbox"/>
2 ... 10 V	<input checked="" type="checkbox"/>	<input type="checkbox"/>	<input type="checkbox"/>	<input type="checkbox"/>	<input checked="" type="checkbox"/>
0 ... ±5 V	<input type="checkbox"/>	<input checked="" type="checkbox"/>	<input type="checkbox"/>	<input checked="" type="checkbox"/>	<input checked="" type="checkbox"/>
1 ... 5 V	<input checked="" type="checkbox"/>	<input checked="" type="checkbox"/>	<input checked="" type="checkbox"/>	<input checked="" type="checkbox"/>	<input checked="" type="checkbox"/>
0 ... ±20 mA	<input type="checkbox"/>	<input type="checkbox"/>	<input checked="" type="checkbox"/>	<input type="checkbox"/>	<input type="checkbox"/>
4 ... 20 mA	<input checked="" type="checkbox"/>	<input type="checkbox"/>	<input checked="" type="checkbox"/>	<input type="checkbox"/>	<input type="checkbox"/>

Offset (in % of output voltage)	S1			S2
	8	9	10	5
0 %	<input type="checkbox"/>	<input type="checkbox"/>	<input type="checkbox"/>	<input checked="" type="checkbox"/>
-100 %	<input checked="" type="checkbox"/>	<input type="checkbox"/>	<input type="checkbox"/>	<input checked="" type="checkbox"/>
-50 %	<input type="checkbox"/>	<input checked="" type="checkbox"/>	<input type="checkbox"/>	<input checked="" type="checkbox"/>
+50 %	<input type="checkbox"/>	<input type="checkbox"/>	<input checked="" type="checkbox"/>	<input checked="" type="checkbox"/>
+100 %	<input type="checkbox"/>	<input type="checkbox"/>	<input checked="" type="checkbox"/>	<input checked="" type="checkbox"/>

Zero pot. activated: additional ±25 %

Switch S3		3
Bandwidth 10 kHz		<input type="checkbox"/>
Bandwidth 10 Hz		<input checked="" type="checkbox"/>
Set range can be documented on side of housing.		<input type="checkbox"/>

■ = on  
□ = off

**Active Converter, PT100/RTD**

- Two way isolation between input and output/power supply
- PT100 two or three conductor
- Power supply can be cross-connected using center jumpers
- Low power loss

**931H-P2C1D-DC**

Specifications	<b>Active Converter, PT100/RTD</b>	
Wiring Diagram		
Standards Compliance	UL 508, UL 1604, UL 60079-15, CSA E60079-15:02, CSA C22.2 No. 213-1987, CSA C22.2 No. 142-M1987, EN 50178:1997, EN 60079-0:2006, EN 60079-15:2005, EN 61000-6-1:2007, EN 61000-6-2: 2005, EN 61000-6-3:2007, EN 61000-6-4:2007	
Certifications	cULus (Class 1, Div. 2/Zone 2, Groups A, B, C and D, NRAG/7.E10314 and NWGD/7.E10314 ), CE, ATEX (Class 1, Zone 2, Demko 09ATEX 147279X)	
<b>Input Ratings</b>		
Sensor	PT100/2-/3-conductor (to IEC 751)	
Supply Current	0.8 mA	
Temperature Input Rating	0...100 °C	
Input	Passive	
<b>Output Ratings</b>		
Voltage	0...10V / 0...5V	
Current	0...20 mA / 4...20 mA	
Load Impedance (voltage/current)	≥ 10 kΩ / ≤ 300 Ω, ≤ 400 Ω @ 24V	
Accuracy	< 0.5% of measuring range	
Temperature Coefficient	≤ 250 ppm/K of final value	
Step Response Time	< 0.7 s	
Output	Active	
<b>General Specifications</b>		
Supply Voltage	24V DC ± 10 %	
Power Consumption	approx. 0.6 W	
Operating Temperature	0 °C...+55 °C	
Storage Temperature	-20 °C...+85 °C	
Default Settings	0...20 mA	
Rated Insulation Voltage	100V	
Impulse Withstand Voltage	1.5kV	
Isolation Voltage Input - Output	500V <sub>eff</sub> / 1 s	
Surge Category	III	
Pollution Severity	2	
Connection Type	Screw	
L x W x H (mm)	88 x 6.1 x 97.8	
<b>Signal Conditioner</b>	<b>Cat. No.</b>	<b>Pkg. Quantity</b>
	<b>931H-P2C1D-DC</b>	<b>1</b>

**Setting options/switch position**

Output	Switch			
	1	2	3	4
0 ... 10 V	■	■	■	□
0 ... 20 mA	□	□	□	□
4 ... 20 mA	□	□	□	■
0 ... 5 V	■	■	■	■

■ = on  
 □ = off

**Connection**

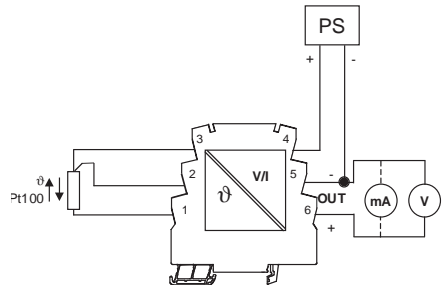



Bulletin 931  
**Signal Conditioners**  
 RTD Signal Conditioners

**Passive Converter, PT100/RTD**

- For two or three conductor PT100 sensors
- Loop-fed output current
- High accuracy and linearity

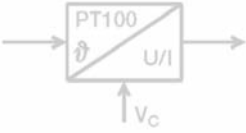
**931H-P2A2N-OP**

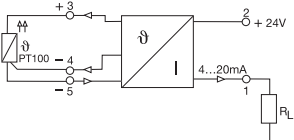
					
Specifications	<b>Passive Converter, PT100/RTD</b>				
Wiring Diagram					
Standards Compliance	UL 508, CSA C22.2 No. 142-M1987, CSA C22.2 No. 0-10, CSA C22.2 No. 14-10, EN 50178:1997, EN 61000-6-1:2007, EN 61000-6-2: 2005, EN 61000-6-3:2007, EN 61000-6-4:2007				
Certifications	cURus (NRAQ2/8.E113724), CSA, CE				
<b>Input Ratings</b>					
Sensor	PT100/2-/3-conductor (to IEC 751)				
Temperature Input Range	0 °C...+200 °C				
Input	Passive				
<b>Output Ratings</b>					
Current	4...20 mA				
Load Impedance (voltage/current)	— / ≤ 600 Ω				
Accuracy	typical 0.2%, max. 0.5% of FSR				
Step Response Time	10 ms				
Output	Passive				
<b>General Specifications</b>					
Supply Voltage	9...30V DC				
Power Type	Output Loop Powered				
Operating Temperature	0 °C...+50 °C				
Storage Temperature	-20 °C...+85 °C				
Connection Type	Tension Clamp				
L x W x H (mm)	91 x 6 x 93.2				
Signal Conditioner	<table border="1" style="width: 100%;"> <tr> <th style="width: 50%;">Cat. No.</th> <th style="width: 50%;">Pkg. Quantity</th> </tr> <tr> <td><b>931H-P2A2N-OP</b></td> <td>1</td> </tr> </table>	Cat. No.	Pkg. Quantity	<b>931H-P2A2N-OP</b>	1
	Cat. No.	Pkg. Quantity			
<b>931H-P2A2N-OP</b>	1				
End Barrier (required)	<table border="1" style="width: 100%;"> <tr> <th style="width: 50%;">Cat. No.</th> <th style="width: 50%;">Pkg. Quantity</th> </tr> <tr> <td><b>931H-EB1</b></td> <td>10</td> </tr> </table>	Cat. No.	Pkg. Quantity	<b>931H-EB1</b>	10
Cat. No.	Pkg. Quantity				
<b>931H-EB1</b>	10				

### Active Converter, 3-Way, RTD

- Universally adjustable using DIP switch
- Bul. 931S Configurator to assist with DIP switch selection, download at [www.ab.com](http://www.ab.com)
- Three way isolation
- Linearization
- Power supply can be cross-connected using center jumpers

#### 931S-P1C2D-DC

Specifications	<b>Active Converter, 3 Way, RTD</b>	
Wiring Diagram		
Standards Compliance	UL 508, UL 1604, CSA C22.2 No. 142-M1987, CSA C22.2 No. 213-1987, EN 50178:1997, EN 61000-6-1:2007, EN 61000-6-2:2005, EN 61000-6-3:2007, EN 61000-6-4:2007	
Certifications	cULus (Class 1, Div. 2, Groups A, B, C and D, NRAG/7.E10314), CE	
<b>Input Ratings</b>		
Sensor	PT100/2-/3-/4-cond., Ni100/2-/3-/4-cond., potentiometer: min. 0...100 Ω, max. 0...100 kΩ, resistor: 0...450 Ω	
Temperature Range	Configurable	
Input	Passive	
<b>Output Ratings</b>		
Voltage	0...10V	
Current	0...20 mA / 4...20 mA	
Load Impedance (voltage/current)	≥ 1 kΩ / ≤ 600 Ω	
Step Response Time	fast/ slow: 2-, 3-, 4-conductor: 1.2 / 2.2 s; potentiometer: 0.5 / 1.1 s	
Line resistance in measuring	50 Ω for 3- and 4- conductor	
Offset Current/ Voltage	max 100 μA/max. 0.05V	
Wire Break Detection	LED flashed (output value > 20 mA, >10V)	
Fine Adjustment	≥ ± 5 %, Version 1: > = 12.5% / Poti: 12.5...25%	
Status Indicator	Active: LED On; Wire broken: LED Flashing; Error: LED Off	
Output	Active	
<b>General Specifications</b>		
Supply Voltage	24V DC ± 25 %	
Power Consumption	830...880...980 mW at I <sub>OUT</sub> = 20 mA	
Current-carrying Capacity of Cross-Connect	≤ 2 A	
Operating Temperature	0 °C...+55 °C	
Storage Temperature	-20 °C...+85 °C	
Default Settings	PT100/3-cond./ 0...100°C / 4...20 mA / man. fine calib.: off / slow step response	
Rated Insulation Voltage	300V	
Impulse Withstand Voltage	4 kV	
Isolation Voltage Input - Output	2 kV <sub>eff</sub> / 5 s	
Surge Category	III	
Pollution Severity	2	
Connection Type	Screw	
L x W x D	92.4 x 17.5 x 112.4	
Signal Conditioner	Cat. No.	Pkg. Quantity
	<b>931S-P1C2D-DC</b>	1

#### Switch positions/setting options

Input	Switch 1		
	1	2	3
PT100 2-conductor	■	■	■
PT100 3-conductor	□	■	■
PT100 4-conductor	■	□	■
R 2-conductor	□	□	■
Ni100 2-conductor	■	■	□
Ni100 3-conductor	□	■	■
Ni100 4-conductor	■	□	□
Potentiometer	□	□	□

Selection of minimum input size						
θ <sub>min</sub>	R <sub>min</sub>	Poti <sub>min</sub>	Switch 1			
			4	5	6	7
0 °C	0 Ω	0 %	■	■	■	■
-10 °C	10 Ω	10 %	□	■	■	■
-20 °C	20 Ω	20 %	■	■	□	■
-25 °C	20 Ω	25 %	■	■	□	□
-30 °C	30 Ω	30 %	■	□	■	■
-40 °C	40 Ω	40 %	■	□	■	□
-50 °C	50 Ω	50 %	■	□	□	■
-60 °C	60 Ω	60 %	■	□	□	□
-70 °C	70 Ω	70 %	□	■	■	■
-80 °C	80 Ω	80 %	□	■	■	□
-90 °C	90 Ω	90 %	□	□	■	■
-100 °C	100 Ω	100 %	□	□	■	■
-150 °C	150 Ω	---	□	□	■	■
-200 °C	200 Ω	---	□	□	■	□
Special range	---	---	□	□	□	■

#### Activating the manual fine calibration

Man. Cal.	Switch 1
	8
On	□
Off	■

Choice of measuring range							
T	R	Potentiometer	Switch 2				
			1	2	3	4	5
40K	20 Ω	20 %	■	■	■	■	■
50K	25 Ω	25 %	■	■	■	■	□
60K	30 Ω	30 %	■	■	■	■	□
70K	35 Ω	35 %	■	■	■	□	□
80K	40 Ω	40 %	■	■	□	■	□
90K	45 Ω	45 %	■	■	■	■	□
100K	50 Ω	50 %	■	■	□	□	■
110K	55 Ω	55 %	■	■	□	□	v
120K	60 Ω	60 %	■	□	■	■	■
125K	62.5 Ω	62.5 %	■	□	■	■	□
130K	65 Ω	65 %	■	□	■	■	□
140K	70 Ω	70 %	■	□	■	□	□
150K	75 Ω	75 %	■	□	□	■	■
160K	80 Ω	80 %	■	□	■	■	□
170K	85 Ω	85 %	■	□	□	■	■
180K	90 Ω	90 %	■	□	□	□	□
190K	95 Ω	95 %	□	■	■	■	■
200K	100 Ω	100 %	□	■	■	■	□
250K	125 Ω	---	□	■	■	□	■
300K	150 Ω	---	□	■	■	□	□
350K	175 Ω	---	□	■	□	■	■
400K	200 Ω	---	□	■	■	■	■
450K	225 Ω	---	□	■	□	■	■
500K	250 Ω	---	□	■	□	■	□
550K	275 Ω	---	□	□	■	■	■
600K	300 Ω	---	□	□	■	■	□
650K	325 Ω	---	□	□	■	□	■
700K	350 Ω	---	□	□	■	■	□
750K	375 Ω	---	□	□	□	■	■
800K	400 Ω	---	□	□	□	■	■
850K	425 Ω	---	□	□	□	■	■
900K	450 Ω	---	□	□	□	□	■

Output	Switch 2	
	6	7
0...10V	■	□
0...20 mA	□	□
4...20 mA	□	■



Step Response	Switch 2	
	8	8
Slow	■	□
Quick *	□	□

\* less exact measuring

### Thermocouple, Type J

- Two-way isolation between input and output/power supply
- Cold junction compensation
- Linearization
- Output can be switched via DIP switch

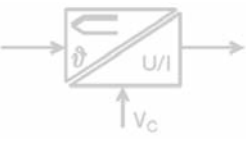
### 931H-T1C1D-DC

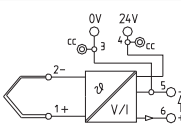
		
Specifications	<b>Thermocouple, Type J</b>	
Wiring Diagram		
Standards Compliance	UL 508, UL 1604, UL 60079-15, CSA E60079-15:02, CSA C22.2 No. 213-1987, CSA C22.2 No. 142-M1987, EN 50178:1997, EN 60079-0:2006, EN 60079-15:2005, EN 61000-6-1:2007, EN 61000-6-2: 2005, EN 61000-6-3:2007, EN 61000-6-4:2007	
Certifications	cULus (Class 1, Div. 2/Zone 2, Groups A, B, C and D, NRAG/7.E10314 and NWGD/7.E10314 ), CE, ATEX (Class 1, Zone 2, Demko 09ATEX 147279X)	
<b>Input Ratings</b>		
Sensor	Thermo element to IEC 584, type: J	
Temperature Input Rating	0...700 °C	
Input	Passive	
<b>Output Ratings</b>		
Voltage	0...10V / 0...5V	
Current	0...20 mA / 4...20 mA	
Load Impedance (voltage/current)	≥ 10 kΩ / ≤ 300 Ω, ≤ 400 Ω @ 24V	
Accuracy	< 0.7% of measuring range	
Temperature Coefficient	≤ 250 ppm/K of final value	
Step Response Time	< 0.7 s	
Wire Break Detection	output value: > 20 mA, >10V	
Residual Ripple	< 20 mV <sub>eff</sub>	
Output	Active	
<b>General Specifications</b>		
Supply Voltage	24V DC ± 10 %	
Power Consumption	approx. 0.6 W	
Current Carrying Capacity of Cross Connect	≤ 2 A	
Operating Temperature	0 °C...+55 °C	
Storage Temperature	-20 °C...+85 °C	
Default Settings	0...20 mA	
Rated Insulation Voltage	100V	
Impulse Withstand Voltage	1.5 kV	
Isolation Voltage Input - Output	500V <sub>eff</sub> / 1 s	
Surge Category	III	
Pollution Severity	2	
Connection Type	Screw	
L x W x D (mm)	88 x 6.1 x 97.8	
Signal Conditioner	Cat. No.	Pkg. Quantity
	931H-T1C1D-DC	1

#### Setting options/switch position

Output	Switch			
	1	2	3	4
0 ... 10 V	■	■	■	□
0 ... 20 mA	□	□	□	□
4 ... 20 mA	□	□	□	■
0 ... 5 V	■	■	■	■

■ = on  
□ = off

#### Setting options/switch position

Output	Switch			
	1	2	3	4
0 ... 10 V	■	■	■	□
0 ... 20 mA	□	□	□	□
4 ... 20 mA	□	□	□	■
0 ... 5 V	■	■	■	■

■ = on  
□ = off

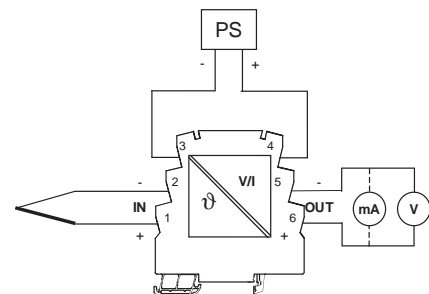

#### Connection



**Thermocouple, Type K**

- Two-way isolation between input and output/power supply
- Cold junction compensation
- Linearization
- Output can be switched via DIP switch

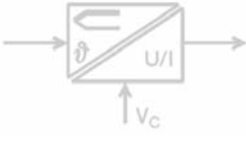
**931H-T2C1D-DC**

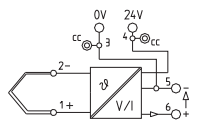
					
Specifications	<b>Thermocouple, Type K</b>				
Wiring Diagram					
Standards Compliance	UL 508, UL 1604, UL 60079-15, CSA E60079-15:02, CSA C22.2 No. 213-1987, CSA C22.2 No. 142-M1987, EN 50178:1997, EN 60079-0:2006, EN 60079-15:2005, EN 61000-6-1:2007, EN 61000-6-2: 2005, EN 61000-6-3:2007, EN 61000-6-4:2007				
Certifications	cULus (Class 1, Div. 2/Zone 2, Groups A, B, C and D, NRAG/7.E10314 and NWGD/7.E10314 ), CE, ATEX (Class 1, Zone 2, Demko 09ATEX 147279X)				
<b>Input Ratings</b>					
Sensor	Thermo element to IEC 584, type: K				
Temperature Input Rating	0...1000 °C				
Input	Passive				
<b>Output Ratings</b>					
Voltage	0...10V / 0...5V				
Current	0...20 mA / 4...20 mA				
Load Impedance (voltage/current)	≥ 10 kΩ / ≤ 300 Ω, ≤ 400 Ω @ 24V				
Accuracy	< 0.6% of measuring range				
Temperature Coefficient	≤ 250 ppm/K of final value				
Step Response Time	< 0.7 s				
Wire Break Detection	output value: .> 20 mA, >10V				
Residual Ripple	< 20 mV <sub>eff</sub>				
Output	Active				
<b>General Specifications</b>					
Supply Voltage	24V DC ± 10 %				
Power Consumption	approx. 0.6 W				
Current Carrying Capacity of Cross Connect	≤ 2 A				
Operating Temperature	0 °C...+55 °C				
Storage Temperature	-20 °C...+85 °C				
Default Settings	0...20 mA				
Rated Insulation Voltage	100V				
Impulse Withstand Voltage	1.5 kV				
Isolation Voltage Input - Output	500V <sub>eff</sub> / 1 s				
Surge Category	III				
Pollution Severity	2				
Connection Type	Screw				
L x W x D (mm)	88 x 6.1 x 97.8				
<b>Signal Conditioner</b>	<table border="1" style="width: 100%;"> <tr> <td style="text-align: center;">Cat. No.</td> <td style="text-align: center;">Pkg. Quantity</td> </tr> <tr> <td style="text-align: center;">931H-T2C1D-DC</td> <td style="text-align: center;">1</td> </tr> </table>	Cat. No.	Pkg. Quantity	931H-T2C1D-DC	1
Cat. No.	Pkg. Quantity				
931H-T2C1D-DC	1				

Setting options/switch position

Output	Switch			
	1	2	3	4
0 ... 10 V	■	■	■	□
0 ... 20 mA	□	□	□	□
4 ... 20 mA	□	□	□	■
0 ... 5 V	■	■	■	■

■ = on  
 □ = off



# Signal Conditioners

## Thermocouple Signal Conditioners

### Universal Thermocouple, 3-Way

- Universally adjustable using DIP switch
- 931S Configurator to assist with DIP switch selection, download at [www.ab.com](http://www.ab.com)
- Three way isolation
- Internal cold-junction compensation
- Power supply can be cross-connected using center jumpers

### 931S-T9C2D-DC

Specifications	<b>Universal Thermocouple, 3 Way</b>	
Wiring Diagram		
Standards Compliance	UL 508, UL 1604, CSA C22.2 No. 142-M1987, CSA C22.2 No. 213-1987, EN 50178:1997, EN 61000-6-1:2007, EN 61000-6-2: 2005, EN 61000-6-3:2007, EN 61000-6-4:2007	
Certifications	cULus (Class 1, Div. 2, Groups A, B, C and D, NRAG/7.E10314), CE	
<b>Input Ratings</b>		
Sensor	Thermo element (IEC 584) type: K,J,T,E,N,R,S,B	
Temperature Range	-200...+1820 °C	
Input	Passive	
<b>Output Ratings</b>		
Voltage	0...10V	
Current	0...20 mA / 4...20 mA	
Load Impedance (voltage/current)	≥ 1 kΩ / ≤ 600 Ω	
Step Response Time	max. 1.4 s; with filter, max. 7.5 s	
Line resistance in measuring circuit	50 Ω for 3- and 4-conductor	
Offset Current/Voltage	≥ 1 kΩ / ≤ 600 Ω	
Wire Break Detection	LED Flashes (output value > 20 mA, >10V)	
Fine Adjustment	± 5 % (switchable)	
Status Indicator	Active: LED On; Wire Broken: LED Flashes; Error: LED Off	
Output	Active	
<b>General Specifications</b>		
Supply Voltage	24V DC ± 25 %	
Power Consumption	830...880...980mW at I <sub>OUT</sub> = 20 mA	
Current-carrying Capacity of Cross-Connect	≤ 2 A	
Operating Temperature	0 °C...+55 °C	
Storage Temperature	-20 °C...+85 °C	
Default Settings	Type K/ 0...1000 °C / 4...20 mA / filter off / man. calibration off	
Rated Insulation Voltage	300V	
Impulse Withstand Voltage	4 kV	
Isolation Voltage Input - Output	2 kV <sub>eff</sub> / 5 s	
Surge Category	III	
Pollution Severity	2	
Connection Type	Screw	
L x W x D (mm)	92.4 x 17.5 x 112.4	
Signal Conditioner	Cat. No.	Pkg. Quantity
	<b>931S-T9C2D-DC</b>	1



Typ	Select of thermocoupler			Selection of minimum temperature						
	SW1 1	SW1 2	SW1 3	min	SW1					
K	<input checked="" type="checkbox"/>	<input checked="" type="checkbox"/>	<input checked="" type="checkbox"/>	0°C	<input checked="" type="checkbox"/>	<input checked="" type="checkbox"/>	<input checked="" type="checkbox"/>	<input checked="" type="checkbox"/>	<input checked="" type="checkbox"/>	<input checked="" type="checkbox"/>
J	<input type="checkbox"/>	<input type="checkbox"/>	<input type="checkbox"/>	-10°C	<input checked="" type="checkbox"/>	<input checked="" type="checkbox"/>	<input checked="" type="checkbox"/>	<input checked="" type="checkbox"/>	<input checked="" type="checkbox"/>	<input checked="" type="checkbox"/>
T	<input type="checkbox"/>	<input type="checkbox"/>	<input type="checkbox"/>	-20°C	<input checked="" type="checkbox"/>	<input checked="" type="checkbox"/>	<input checked="" type="checkbox"/>	<input checked="" type="checkbox"/>	<input checked="" type="checkbox"/>	<input checked="" type="checkbox"/>
E	<input type="checkbox"/>	<input type="checkbox"/>	<input type="checkbox"/>	-30°C	<input checked="" type="checkbox"/>	<input checked="" type="checkbox"/>	<input checked="" type="checkbox"/>	<input checked="" type="checkbox"/>	<input checked="" type="checkbox"/>	<input checked="" type="checkbox"/>
N	<input type="checkbox"/>	<input type="checkbox"/>	<input type="checkbox"/>	-40°C	<input checked="" type="checkbox"/>	<input checked="" type="checkbox"/>	<input checked="" type="checkbox"/>	<input checked="" type="checkbox"/>	<input checked="" type="checkbox"/>	<input checked="" type="checkbox"/>
R	<input type="checkbox"/>	<input type="checkbox"/>	<input type="checkbox"/>	-50°C	<input checked="" type="checkbox"/>	<input checked="" type="checkbox"/>	<input checked="" type="checkbox"/>	<input checked="" type="checkbox"/>	<input checked="" type="checkbox"/>	<input checked="" type="checkbox"/>
S	<input type="checkbox"/>	<input type="checkbox"/>	<input type="checkbox"/>	-100°C	<input checked="" type="checkbox"/>	<input checked="" type="checkbox"/>	<input checked="" type="checkbox"/>	<input checked="" type="checkbox"/>	<input checked="" type="checkbox"/>	<input checked="" type="checkbox"/>
B	<input type="checkbox"/>	<input type="checkbox"/>	<input type="checkbox"/>	-150°C	<input checked="" type="checkbox"/>	<input checked="" type="checkbox"/>	<input checked="" type="checkbox"/>	<input checked="" type="checkbox"/>	<input checked="" type="checkbox"/>	<input checked="" type="checkbox"/>
				-200°C	<input type="checkbox"/>	<input checked="" type="checkbox"/>	<input checked="" type="checkbox"/>	<input checked="" type="checkbox"/>	<input checked="" type="checkbox"/>	<input checked="" type="checkbox"/>
				+50°C	<input type="checkbox"/>	<input type="checkbox"/>	<input checked="" type="checkbox"/>	<input checked="" type="checkbox"/>	<input checked="" type="checkbox"/>	<input checked="" type="checkbox"/>
				+100°C	<input type="checkbox"/>	<input type="checkbox"/>	<input type="checkbox"/>	<input checked="" type="checkbox"/>	<input checked="" type="checkbox"/>	<input checked="" type="checkbox"/>
				+150°C	<input type="checkbox"/>	<input type="checkbox"/>	<input type="checkbox"/>	<input type="checkbox"/>	<input checked="" type="checkbox"/>	<input checked="" type="checkbox"/>
				+200°C	<input type="checkbox"/>	<input type="checkbox"/>	<input type="checkbox"/>	<input type="checkbox"/>	<input type="checkbox"/>	<input checked="" type="checkbox"/>
				+250°C	<input type="checkbox"/>	<input type="checkbox"/>	<input type="checkbox"/>	<input type="checkbox"/>	<input type="checkbox"/>	<input checked="" type="checkbox"/>
				500°C	<input type="checkbox"/>	<input type="checkbox"/>	<input type="checkbox"/>	<input type="checkbox"/>	<input type="checkbox"/>	<input checked="" type="checkbox"/>
				Special range	<input type="checkbox"/>	<input type="checkbox"/>	<input type="checkbox"/>	<input type="checkbox"/>	<input type="checkbox"/>	<input type="checkbox"/>

Span	Selection of temperature span					Selection of output	
	SW2 1	SW2 2	SW2 3	SW2 4	SW2 5	Output 6	SW2 7
100°C	<input checked="" type="checkbox"/>	<input checked="" type="checkbox"/>	<input checked="" type="checkbox"/>	<input checked="" type="checkbox"/>	<input checked="" type="checkbox"/>	0...10V	<input type="checkbox"/>
150°C	<input checked="" type="checkbox"/>	<input checked="" type="checkbox"/>	<input checked="" type="checkbox"/>	<input checked="" type="checkbox"/>	<input type="checkbox"/>	0...20mA	<input type="checkbox"/>
200°C	<input checked="" type="checkbox"/>	<input checked="" type="checkbox"/>	<input checked="" type="checkbox"/>	<input checked="" type="checkbox"/>	<input type="checkbox"/>	4...20mA	<input type="checkbox"/>
250°C	<input checked="" type="checkbox"/>	<input checked="" type="checkbox"/>	<input checked="" type="checkbox"/>	<input checked="" type="checkbox"/>	<input type="checkbox"/>		
300°C	<input checked="" type="checkbox"/>	<input checked="" type="checkbox"/>	<input checked="" type="checkbox"/>	<input checked="" type="checkbox"/>	<input type="checkbox"/>		
350°C	<input checked="" type="checkbox"/>	<input checked="" type="checkbox"/>	<input checked="" type="checkbox"/>	<input checked="" type="checkbox"/>	<input type="checkbox"/>		
400°C	<input checked="" type="checkbox"/>	<input checked="" type="checkbox"/>	<input checked="" type="checkbox"/>	<input checked="" type="checkbox"/>	<input type="checkbox"/>		
450°C	<input checked="" type="checkbox"/>	<input checked="" type="checkbox"/>	<input checked="" type="checkbox"/>	<input checked="" type="checkbox"/>	<input type="checkbox"/>		
500°C	<input checked="" type="checkbox"/>	<input checked="" type="checkbox"/>	<input checked="" type="checkbox"/>	<input checked="" type="checkbox"/>	<input type="checkbox"/>		
550°C	<input checked="" type="checkbox"/>	<input checked="" type="checkbox"/>	<input checked="" type="checkbox"/>	<input checked="" type="checkbox"/>	<input type="checkbox"/>		
600°C	<input checked="" type="checkbox"/>	<input checked="" type="checkbox"/>	<input checked="" type="checkbox"/>	<input checked="" type="checkbox"/>	<input type="checkbox"/>		
650°C	<input checked="" type="checkbox"/>	<input checked="" type="checkbox"/>	<input checked="" type="checkbox"/>	<input checked="" type="checkbox"/>	<input type="checkbox"/>		
700°C	<input checked="" type="checkbox"/>	<input checked="" type="checkbox"/>	<input checked="" type="checkbox"/>	<input checked="" type="checkbox"/>	<input type="checkbox"/>		
750°C	<input checked="" type="checkbox"/>	<input checked="" type="checkbox"/>	<input checked="" type="checkbox"/>	<input checked="" type="checkbox"/>	<input type="checkbox"/>		
800°C	<input checked="" type="checkbox"/>	<input checked="" type="checkbox"/>	<input checked="" type="checkbox"/>	<input checked="" type="checkbox"/>	<input type="checkbox"/>		
850°C	<input checked="" type="checkbox"/>	<input checked="" type="checkbox"/>	<input checked="" type="checkbox"/>	<input checked="" type="checkbox"/>	<input type="checkbox"/>		
900°C	<input checked="" type="checkbox"/>	<input checked="" type="checkbox"/>	<input checked="" type="checkbox"/>	<input checked="" type="checkbox"/>	<input type="checkbox"/>		
950°C	<input checked="" type="checkbox"/>	<input checked="" type="checkbox"/>	<input checked="" type="checkbox"/>	<input checked="" type="checkbox"/>	<input type="checkbox"/>		
1000°C	<input checked="" type="checkbox"/>	<input checked="" type="checkbox"/>	<input checked="" type="checkbox"/>	<input checked="" type="checkbox"/>	<input type="checkbox"/>		
1050°C	<input checked="" type="checkbox"/>	<input checked="" type="checkbox"/>	<input checked="" type="checkbox"/>	<input checked="" type="checkbox"/>	<input type="checkbox"/>		
1100°C	<input checked="" type="checkbox"/>	<input checked="" type="checkbox"/>	<input checked="" type="checkbox"/>	<input checked="" type="checkbox"/>	<input type="checkbox"/>		
1150°C	<input checked="" type="checkbox"/>	<input checked="" type="checkbox"/>	<input checked="" type="checkbox"/>	<input checked="" type="checkbox"/>	<input type="checkbox"/>		
1200°C	<input checked="" type="checkbox"/>	<input checked="" type="checkbox"/>	<input checked="" type="checkbox"/>	<input checked="" type="checkbox"/>	<input type="checkbox"/>		
1250°C	<input checked="" type="checkbox"/>	<input checked="" type="checkbox"/>	<input checked="" type="checkbox"/>	<input checked="" type="checkbox"/>	<input type="checkbox"/>		
1300°C	<input checked="" type="checkbox"/>	<input checked="" type="checkbox"/>	<input checked="" type="checkbox"/>	<input checked="" type="checkbox"/>	<input type="checkbox"/>		
1350°C	<input checked="" type="checkbox"/>	<input checked="" type="checkbox"/>	<input checked="" type="checkbox"/>	<input checked="" type="checkbox"/>	<input type="checkbox"/>		
1400°C	<input checked="" type="checkbox"/>	<input checked="" type="checkbox"/>	<input checked="" type="checkbox"/>	<input checked="" type="checkbox"/>	<input type="checkbox"/>		
1450°C	<input checked="" type="checkbox"/>	<input checked="" type="checkbox"/>	<input checked="" type="checkbox"/>	<input checked="" type="checkbox"/>	<input type="checkbox"/>		
1500°C	<input checked="" type="checkbox"/>	<input checked="" type="checkbox"/>	<input checked="" type="checkbox"/>	<input checked="" type="checkbox"/>	<input type="checkbox"/>		
1600°C	<input checked="" type="checkbox"/>	<input checked="" type="checkbox"/>	<input checked="" type="checkbox"/>	<input checked="" type="checkbox"/>	<input type="checkbox"/>		
1700°C	<input checked="" type="checkbox"/>	<input checked="" type="checkbox"/>	<input checked="" type="checkbox"/>	<input checked="" type="checkbox"/>	<input type="checkbox"/>		
1800°C	<input checked="" type="checkbox"/>	<input checked="" type="checkbox"/>	<input checked="" type="checkbox"/>	<input checked="" type="checkbox"/>	<input type="checkbox"/>		

Temperature coefficient	
K -200°C...-150°C	± (5K + 0,1% of set range)
-150°C...1200°C	± (3K + 0,1% of set range)
1200°C...1372°C	± (4K + 0,1% of set range)
J -200°C...-150°C	± (4K + 0,1% of set range)
-150°C...1200°C	± (3K + 0,1% of set range)
T -200°C...-150°C	± (5K + 0,1% of set range)
-150°C...400°C	± (3K + 0,1% of set range)
E -200°C...-150°C	± (4K + 0,1% of set range)
-150°C...1000°C	± (3K + 0,1% of set range)
N -200°C...-150°C	± (6K + 0,1% of set range)
-150°C...1300°C	± (3K + 0,1% of set range)
R -50°C...200°C	± (10K + 0,1% of set range)
200°C...1760°C	± (6K + 0,1% of set range)
S -50°C...200°C	± (10K + 0,1% of set range)
200°C...1760°C	± (6K + 0,1% of set range)
B 50°C...250°C	± (25K + 0,1% of set range)
250°C...500°C	± (10K + 0,1% of set range)
500°C...1820°C	± (6K + 0,1% of set range)

Passive Converter, Current Monitoring - Loop Powered

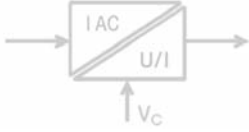
**931S-A3A2D-OP**

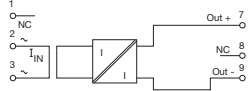
					
<b>Specifications</b>	<b>Passive Converter, Monitoring - Loop Powered</b>				
<b>Wiring Diagram</b>					
<b>Standards Compliance</b>	UL 508, UL 1604, UL 60079-15, CSA E60079-15:02, CSA C22.2 No. 213-1987, CSA C22.2 No. 142-M1987, EN 50178:1997, EN 60079-0:2006, EN 60079-15:2005, EN 61000-6-1:2007, EN 61000-6-2: 2005, EN 61000-6-3:2007, EN 61000-6-4:2007				
<b>Certifications</b>	cULus (Class 1, Div. 2/Zone 2, Groups A, B, C and D, NRAG/7.E10314 and NWGD/7.E10314 ), CE, ATEX (Class 1, Zone 2, Demko 09ATEX 0929065X)				
<b>Input Ratings</b>					
Current	0...1 A AC/ 0...5 A AC/ 0...10 A AC				
Frequency	50...60 Hz				
Max Current	100 A for 1 s				
Voltage of Measuring Circuit	250 V AC				
Sensor	Transforming (internally)				
Input	Passive				
<b>Output Ratings</b>					
Voltage	—				
Current	4...20 mA				
Load Impedance (voltage/current)	— / ≤ 600 Ω				
Step Response Time	Typically 700 ms				
Temperature Coefficient	≤ 200 ppm/ K				
Accuracy	0.5% FSR				
Offset Current/Voltage	max. 100 μA/ —				
Status Indicator	LED ON: OK; FLASHING: signal out of range; LED OFF: Error				
Output	Passive				
<b>General Specifications</b>					
Supply Voltage	13...30V DC				
Power Type	Output Loop Powered				
Operating Temperature	0 °C...+50 °C				
Storage Temperature	-20 °C...+70 °C				
Default Settings	0...5 A AC, 4...20 mA				
Rated Insulation Voltage	300V				
Impulse Withstand Voltage	6kV				
Isolation Voltage Input - Output	4kV <sub>eff</sub> / 5 s				
Surge Category	III				
Pollution Severity	2				
Connection Type	Screw				
L x W x D (mm)	72 x 22.5 x 92.4				
<b>Signal Conditioner</b>	<table border="1" style="width: 100%; border-collapse: collapse;"> <tr> <td style="text-align: center;">Cat. No.</td> <td style="text-align: center;">Pkg. Quantity</td> </tr> <tr> <td style="text-align: center;">931S-A3A2D-OP</td> <td style="text-align: center;">1</td> </tr> </table>	Cat. No.	Pkg. Quantity	931S-A3A2D-OP	1
Cat. No.	Pkg. Quantity				
931S-A3A2D-OP	1				

Input	Switch			
	1	2	3	4
1 Aa	<input type="checkbox"/>	<input type="checkbox"/>	<input type="checkbox"/>	<input checked="" type="checkbox"/>
5 Aa	<input type="checkbox"/>	<input checked="" type="checkbox"/>	<input type="checkbox"/>	<input type="checkbox"/>
10 Aa	<input checked="" type="checkbox"/>	<input type="checkbox"/>	<input type="checkbox"/>	<input type="checkbox"/>

Frequency	Switch			
	1	2	3	4
50 Hz	<input type="checkbox"/>	<input type="checkbox"/>	<input type="checkbox"/>	<input type="checkbox"/>
60 Hz	<input type="checkbox"/>	<input type="checkbox"/>	<input type="checkbox"/>	<input checked="" type="checkbox"/>

■ = on  
 □ = off

Active Converter, Monitoring

931S-A3C2D-DC

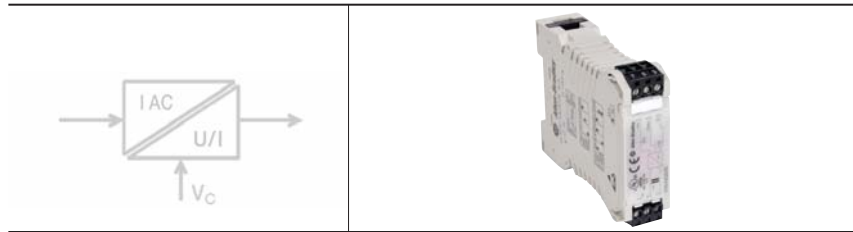

Specifications **Active Converter, Monitoring**

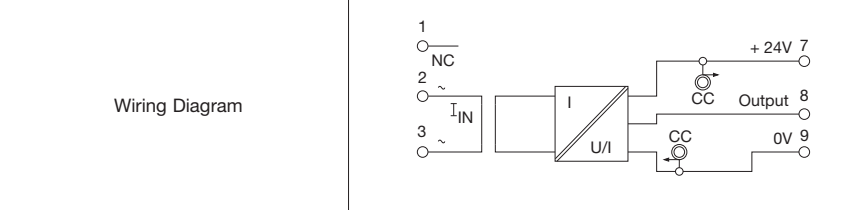

Standards Compliance  
 UL 508, CSA C22.2 No. 142-M1987, EN 50178:1997, EN 61000-6-1:2007, EN 61000-6-2: 2005, EN 61000-6-3:2007, EN 61000-6-4:2007

Certifications  
 cULus (NRAQ/7.E113724), CE

Input	Switch							
	1	2	3	4	5	6	7	8
1 Aa	<input type="checkbox"/>	<input type="checkbox"/>	<input checked="" type="checkbox"/>					
5 Aa	<input checked="" type="checkbox"/>	<input checked="" type="checkbox"/>	<input type="checkbox"/>					
10 Aa	<input checked="" type="checkbox"/>	<input type="checkbox"/>	<input type="checkbox"/>					

Output	Switch							
	1	2	3	4	5	6	7	8
0...10V				<input checked="" type="checkbox"/>	<input type="checkbox"/>	<input checked="" type="checkbox"/>	<input checked="" type="checkbox"/>	<input type="checkbox"/>
0...20 mA				<input type="checkbox"/>	<input type="checkbox"/>	<input type="checkbox"/>	<input type="checkbox"/>	<input checked="" type="checkbox"/>
4...20 mA				<input type="checkbox"/>	<input checked="" type="checkbox"/>	<input type="checkbox"/>	<input type="checkbox"/>	<input checked="" type="checkbox"/>



■ = on  
 □ = off

Input Ratings		
Current	0...1 A AC/ 0...5 A AC/ 0...10 A AC	
Frequency	50...60 Hz	
Max Current	100 A for 1 s	
Voltage of Measuring Circuit	250 V AC	
Sensor	Transforming (internally)	
Input	Passive	
Output Ratings		
Voltage	0...10V	
Current	0...20 mA / 4...20 mA	
Load Impedance (voltage/current)	≥ 1 kΩ / ≤ 600 Ω	
Step Response Time	Typically 700 ms	
Temperature Coefficient	≤ 200 ppm/ K	
Accuracy	0.5% FSR	
Offset Current / Voltage	max. 100 μA/ max. 0.05V	
Status Indicator	LED ON: OK; FLASHING: signal out of range; LED OFF: Error	
Output	Active	
General Specifications		
Supply Voltage	24V DC ± 10 %	
Current Consumption	40 mA at I <sub>OUT</sub> =20 mA	
Current-carrying Capacity of Cross-Connect	≤ 2 A	
Operating Temperature	0 °C...+50 °C	
Storage Temperature	-20 °C...+70 °C	
Default Settings	0...5 A AC, 4...20 mA	
Rated Insulation Voltage	300V	
Impulse Withstand Voltage	6kV	
Isolation Voltage Input - Output	4kV <sub>eff</sub> / 5 s	
Surge Category	III	
Pollution Severity	2	
Connection Type	Screw	
L x W x D (mm)	72 x 22.5 x 92.4	
Signal Conditioner	Cat. No.	Pkg. Quantity
	931S-A3C2D-DC	1

**Active Isolator, Half-Effect Current Monitoring**

- Input/output electrically isolated
- Input and output ranges adjustable using DIP switch
- No calibration necessary

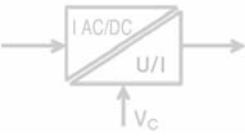
**931S-A4C2D-DCHALL**

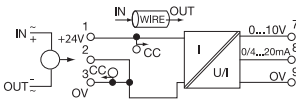
		
<p>Specifications</p>	<p><b>Active Isolator, Half-Effect Monitoring</b></p>	
<p>Wiring Diagram</p>		
<p>Standards Compliance</p>	<p>UL 508, CSA C22.2 No. 142-M1987, EN 50178:1997, EN 61000-6-1:2007, EN 61000-6-2: 2005, EN 61000-6-3:2007, EN 61000-6-4:2007</p>	
<p>Certifications</p>	<p>cULus (NRAQ/7.E113724), CE</p>	
<b>Input Ratings</b>		
<p>Current</p>	<p>0...20 A AC/DC / 0...25 A AC/DC / 0...30 A AC/DC</p>	
<p>Frequency</p>	<p>0...2 kHz (true RMS to DC converter)</p>	
<p>Voltage of Measuring Circuit</p>	<p>400V AC, &gt;400V AC depends on conductor insulation</p>	
<p>Sensor</p>	<p>Hall sensor (internal)</p>	
<p>Diameter of Entry</p>	<p>8 mm</p>	
<p>Input</p>	<p>Passive</p>	
<b>Output Ratings</b>		
<p>Voltage</p>	<p>0...10V</p>	
<p>Current</p>	<p>0...20 mA / 4...20 mA</p>	
<p>Load Impedance (voltage/current)</p>	<p>≥ 1 kΩ / ≤ 600 Ω</p>	
<p>Step Response Time</p>	<p>Typically 700 ms</p>	
<p>Temperature Coefficient</p>	<p>≤ 650 ppm/ K</p>	
<p>Accuracy</p>	<p>1% FSR</p>	
<p>Offset Current / Voltage</p>	<p>max. 150 μA/ max. 0.08V</p>	
<p>Status Indicator</p>	<p>LED ON: OK; FLASHING: signal out of range; LED OFF: Error</p>	
<p>Output</p>	<p>Active</p>	
<b>General Specifications</b>		
<p>Supply Voltage</p>	<p>24V DC ± 10 %</p>	
<p>Current Consumption</p>	<p>50 mA at I<sub>OUT</sub> =20 mA</p>	
<p>Current-carrying Capacity of Cross-Connect</p>	<p>≤ 2 A</p>	
<p>Operating Temperature</p>	<p>0 °C...+50 °C</p>	
<p>Storage Temperature</p>	<p>-20 °C...+70 °C</p>	
<p>Default Settings</p>	<p>0...25 A, 4...20 mA</p>	
<p>Rated Insulation Voltage</p>	<p>300V</p>	
<p>Impulse Withstand Voltage</p>	<p>6kV</p>	
<p>Isolation Voltage Input - Output</p>	<p>4kV<sub>eff</sub> / 5 s</p>	
<p>Surge Category</p>	<p>III</p>	
<p>Pollution Severity</p>	<p>2</p>	
<p>Connection Type</p>	<p>Screw</p>	
<p>L x W x D (mm)</p>	<p>92.4 x 22.5 x 112.4</p>	
<p>Signal Conditioner</p>	<p>Cat. No.</p>	<p>Pkg. Quantity</p>
	<p><b>931S-A4C2D-DCHALL</b></p>	<p>1</p>

Input	Switch				
	1	2	3	4	5
20 A	<input type="checkbox"/>	<input type="checkbox"/>			
25 A	<input type="checkbox"/>	<input checked="" type="checkbox"/>			
30 A		<input checked="" type="checkbox"/>	<input type="checkbox"/>		

■ = on  
 = off

Output	Switch				
	1	2	3	4	5
0...10V			<input checked="" type="checkbox"/>	<input type="checkbox"/>	
0...20 mA			<input type="checkbox"/>	<input type="checkbox"/>	
4...20 mA			<input type="checkbox"/>	<input checked="" type="checkbox"/>	

■ = on  
 = off

Current Type	Switch				
	1	2	3	4	5
AC Current				<input checked="" type="checkbox"/>	
DC Current				<input type="checkbox"/>	

■ = on  
 = off

### Isolator, 3-Way, Limit Value Monitoring

- Three-way Isolation
- Low Trip/ High Trip
- Failsafe/Non-Failsafe
- Two relay outputs

### 931S-C2R1D-DC2R

Specifications	<b>Isolator, 3-Way, Limit Value Monitoring</b>	
Wiring Diagram		
Standards Compliance	UL 508, CSA C22.2 No. 142-M1987, EN 50178:1997, EN 61000-6-1:2007, EN 61000-6-2: 2005, EN 61000-6-3:2007, EN 61000-6-4:2007	
Certifications	cULus (NRAQ/7.E113724), CE	
<b>Input Ratings</b>		
Voltage	0...10V	
Current	0...20 mA / 4...20 mA	
Input Resistance (voltage/current)	≥ 100 kΩ / ≤ 110 Ω	
Input	Passive	
<b>Output Ratings</b>		
Contact Complement	2 change-over contacts	
Contact Material	AgNi 90/10	
Switching Thresholds	1...90% (independently for channel 1 and channel 2)	
Hysteresis	1...10% (independently for channel 1 and channel 2)	
Switching Voltage, Max	253V AC	
Step Response Time	≤ 62 ms	
Continuous Current	3 A	
Temperature Coefficient	≤ 500 ppm/K	
Status Indicator	LED green ON: OK, LED red ON: alarm (per channel)	
Output	Relay	
<b>General Specifications</b>		
Supply Voltage	24V DC ± 25 %	
Power Consumption	typically 1 W both relays picked up	
Current-carrying Capacity of Cross-Connect.	≤ 2 A	
Operating Temperature	-10 °C...+55 °C	
Storage Temperature	-20 °C...+85 °C	
Default Settings	channel A/B: low trip and FAILSAFE	
Rated Voltage	300V	
Impulse Withstand Voltage	4kV	
Isolation Voltage Input - Output	2kV <sub>eff</sub> / 5 s	
Surge Category	III	
Pollution Severity	2	
Connection Type	Screw	
L x W x D (mm)	92.4 x 17.5 x 112.4	
<b>Signal Conditioner</b>	Cat. No.	Pkg. Quantity
	<b>931S-C2R1D-DC2R</b>	1

### Switch position/setting options

function	SW 1			
	1	2	3	4
Channel A High Trip	■			
Channel A Low Trip	□			
Channel B High Trip		■		
Channel B Low Trip		□		
FAILSAFE, Channel 1 & 2			□	□
NON FAILSAFE, Chan. 1 & 2			■	■

■ = on  
□ = off

NON FAILSAFE: The relay picks up when the alarm is triggered

FAILSAFE: The relay drops out when the alarm is triggered. An alarm is also triggered in the FAILSAFE mode, if for example, the operating voltage to the moduls fail

Low Trip: Alarm is triggered if the signal is undershoot the threshold.

High Trip: Alarm is triggered if the signal is overshoot the threshold.

Signal threshold: Adjustments of the signal threshold (1...90)% are made for channel 1 with the potentiometer P1, and separately for channel 2 via potentiometer P2.

Hysteresis: Adjustments of the hysteresis (1...10)% are made for channel 1 with the potentiometer P3, and separately for channel 2 via potentiometer P3.

### Example 1

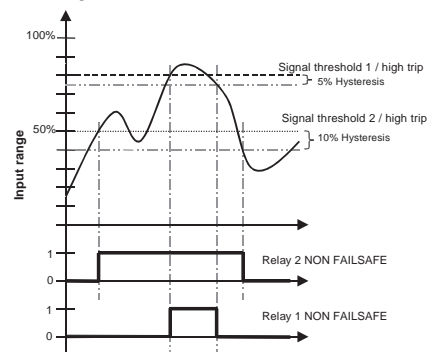

### Example 2

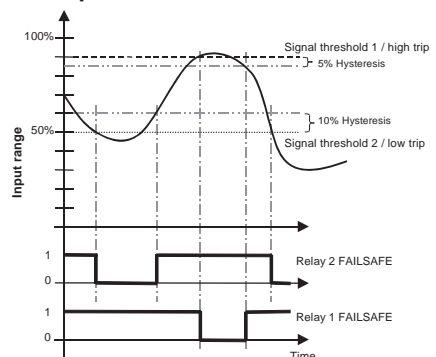

**Isolator, 3-Way, Voltage Monitoring**

- Three-way isolation
- Monitoring of single-phase systems up to 260V AC/DC
- 4 input ranges selected by DIP switches
- One relay with change-over contact
- Switchable hysteresis
- Switch adjusted via potentiometer
- Reset input

**931S-V1R1D-MC1R**

Specifications	<b>Isolator, 3-Way, Monitoring</b>	
Wiring Diagram		
Standards Compliance	EN 50178UL 508, CSA C22.2 No. 142-M1987, EN 50178:1997, EN 61000-6-1:2007, EN 61000-6-2: 2005, EN 61000-6-3:2007, EN 61000-6-4:2007	
Certifications	cULus (NRAQ/7.E113724), CE	
<b>Input Ratings</b>		
Voltage	24...70 / 70...140 / 140...210 / 210...260V AC / DC	
Frequency	50...60 Hz	
Max Voltage	260V AC / DC	
Input	Passive	
<b>Output Ratings</b>		
Switching Voltage, Max	250V AC	
Switching Current, Max	8 A	
Continuous Current	3 A	
Step Response Time	< 300 ms	
Temperature Coefficient	≤ 250 ppm/ K	
Accuracy	< 0.3% of set range	
Hysteresis	24...70V AC, small = 5V / large = 10V	
Status Indicator	LED green = OK / LED red/yellow = alarm status	
Output	Relay	
<b>General Specifications</b>		
Supply Voltage	from the measuring circuit	
Reset Input Voltage Range	18V DC...30V DC	
Minimum Pulse Length	700 ms	
Operating Temperature	-10 °C...+55 °C	
Storage Temperature	-20 °C...+70 °C	
Default Settings	DIP switches: ON = 1,2,5,8 / OFF = 3,4,6,7	
Rated Insulation Voltage	300V	
Impulse Withstand Voltage	4 kV	
Isolation Voltage Input - Output	2 kV <sub>eff</sub>	
Surge Category	III	
Pollution Severity	2	
Connection Type	Screw	
L x W x D (mm)	96.5 x 17.5 x 112.5	
Signal Conditioner	Cat. No.	Pkg. Quantity
	931S-V1R1D-MC1R	1

Input	1	2	3	4	5	6	7	8
24 V AC/DC...70 V AC/DC		■	□	□	□			
70 V AC/DC...140 V AC/DC		□	□	□	■			
140 V AC/DC...210 V AC/DC		□	□	■	□			
210 V AC/DC...260 V AC/DC		□	■	□	□			
<b>Trip</b>								
High Trip		■						
Low Trip		□						
<b>Memory</b>								
Memory on		□						
Memory out			■					
<b>Hysteresis</b>								
Hysteresis small			□					
Hysteresis large				■				
<b>Input voltage</b>								
AC voltage								■
DC voltage								□

■ = on  
 □ = out

**Status indicator**

- Set value not exceeded.
- Alarm status.
- Alarm status can be reset because set value has been exceeded.

**Abb.1: Overvoltage monitoring**

Alarm set to "high trip"  
 (Set permanently to closed-circuit principle.)

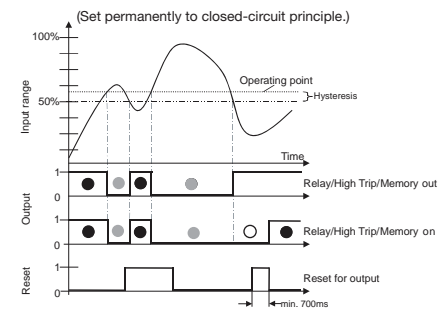

**Abb.2: Undervoltage monitoring**

Alarm set to "low trip"  
 (Set permanently to closed-circuit principle.)

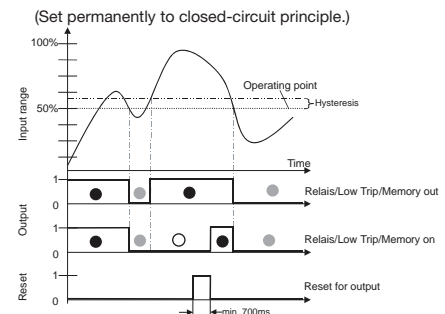

**Bridge Converter, 3-Way**

- Three-way isolation
- Input and output ranges adjustable using DIP switch
- No calibration necessary
- Inverse output signals possible

**931S-B1C6D-DC**

Specifications	<b>Bridge Converter, 3 Way</b>	
Wiring Diagram		
Standards Compliance	UL 508, CSA C22.2 No. 142-M1987, EN 50178:1997, EN 61000-6-1:2007, EN 61000-6-2: 2005, EN 61000-6-3:2007, EN 61000-6-4:2007	
Certifications	cULus (NRAQ/7.E113724), CE	
<b>Input Ratings</b>		
Input Voltage	-500mV...+500mV (adjustable)	
Input Resistance	> 1 mΩ	
Input	Active	
<b>Output Ratings</b>		
Voltage	0...5V / 5...0V / 10...0V / 0...10V	
Current	0...20 mA / 20...0 mA / 4...20 mA / 20...4 mA	
Load Impedance (voltage/current)	≥ 1 kΩ / ≤ 600 Ω	
Step Response Time	Typically <200 ms	
Temperature Coefficient	≤ 250 ppm/ K of output range	
Accuracy	0.3% of output range	
Offset Current / Voltage	max. 100 μA/ max. 0.05V	
Status Indicator	green LED	
Wire Break Detection	output: 0V or 0/4 mA	
Bridge Supply Voltage	+10V, +5V, 4.8...10.2V; offset adjustable; max. 40 mA	
Output	Active	
<b>General Specifications</b>		
Supply Voltage	24V DC ± 25 %	
Power Consumption	max. 1.9 W at I <sub>OUT</sub> = 20 mA	
Current-carrying Capacity of Cross-connect	≤ 2 A	
Operating Temperature	0 °C...+55 °C	
Storage Temperature	-20 °C...+85 °C	
Default Settings	-500 mV...+500 mV / 0...10V / + 10V / standard	
Rated Insulation Voltage	300V	
Impulse Withstand Voltage	4kV	
Isolation Voltage Input - Output	2kV <sub>eff</sub> / 5 s	
Surge Category	III	
Pollution Severity	2	
Connection Type	Screw	
L x W x D (mm)	92.4 x 17.5 x 112.4	
<b>Signal Conditioner</b>	Cat. No.	Pkg. Quantity
	<b>931S-B1C6D-DC</b>	1

**Switch position/setting options**

Input voltage	SW 1									
	1	2	3	4	5	6	7	8	9	10
0...10 mV						<input type="checkbox"/>	<input type="checkbox"/>	<input type="checkbox"/>	<input type="checkbox"/>	<input type="checkbox"/>
0...20 mV						<input type="checkbox"/>	<input type="checkbox"/>	<input type="checkbox"/>	<input checked="" type="checkbox"/>	<input type="checkbox"/>
0...50 mV						<input type="checkbox"/>	<input type="checkbox"/>	<input checked="" type="checkbox"/>	<input type="checkbox"/>	<input type="checkbox"/>
0...100 mV						<input type="checkbox"/>	<input type="checkbox"/>	<input type="checkbox"/>	<input checked="" type="checkbox"/>	<input checked="" type="checkbox"/>
0...200 mV						<input type="checkbox"/>	<input checked="" type="checkbox"/>	<input type="checkbox"/>	<input type="checkbox"/>	<input type="checkbox"/>
0...500 mV						<input type="checkbox"/>	<input checked="" type="checkbox"/>	<input checked="" type="checkbox"/>	<input checked="" type="checkbox"/>	<input type="checkbox"/>
-10 mV...10 mV						<input checked="" type="checkbox"/>	<input type="checkbox"/>	<input type="checkbox"/>	<input type="checkbox"/>	<input type="checkbox"/>
· 20 mV...20 mV						<input checked="" type="checkbox"/>	<input type="checkbox"/>	<input type="checkbox"/>	<input type="checkbox"/>	<input type="checkbox"/>
· 50 mV...50 mV						<input checked="" type="checkbox"/>	<input type="checkbox"/>	<input type="checkbox"/>	<input type="checkbox"/>	<input type="checkbox"/>
· 100 mV...100 mV						<input checked="" type="checkbox"/>	<input type="checkbox"/>	<input checked="" type="checkbox"/>	<input type="checkbox"/>	<input type="checkbox"/>
· 200 mV...200 mV						<input checked="" type="checkbox"/>	<input type="checkbox"/>	<input type="checkbox"/>	<input type="checkbox"/>	<input type="checkbox"/>
· 500 mV...500 mV						<input checked="" type="checkbox"/>	<input checked="" type="checkbox"/>	<input checked="" type="checkbox"/>	<input checked="" type="checkbox"/>	<input type="checkbox"/>
Output										
0...+10 V						<input type="checkbox"/>	<input type="checkbox"/>			
0...+5 V						<input type="checkbox"/>	<input checked="" type="checkbox"/>			
0...20 mA						<input checked="" type="checkbox"/>	<input type="checkbox"/>			
4...20 mA						<input checked="" type="checkbox"/>	<input checked="" type="checkbox"/>			
<b>Bridge supply voltage</b>										
+10V						<input checked="" type="checkbox"/>	<input type="checkbox"/>	<input type="checkbox"/>		
+5V						<input checked="" type="checkbox"/>	<input type="checkbox"/>	<input checked="" type="checkbox"/>		
+4.8...+10.2V adjustable						<input type="checkbox"/>	<input checked="" type="checkbox"/>	<input type="checkbox"/>		
+4.8...+10.2V adjustable man. adjustment and offset possible						<input type="checkbox"/>	<input checked="" type="checkbox"/>	<input checked="" type="checkbox"/>		
<b>Transmission method</b>										
standard output signal										<input type="checkbox"/>
inverse output signal										<input checked="" type="checkbox"/>

■ = on  
 □ = off

**Status LED**

LED on	normal operating
LED off	Error
LED blinks slow	measurement range undershoot U <sub>in</sub> < U <sub>max</sub> - 10 %
LED blinks fast	measurement range overshoot U <sub>in</sub> < U <sub>max</sub> + 10 %

**Application**

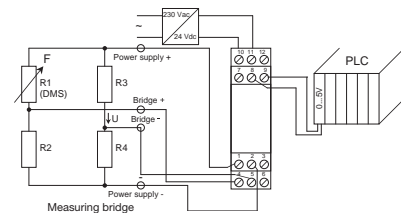

**Example for bridge supply voltage**

<b>Temperature adjustment:</b>	
Input voltage	0...10 mA
Output	0...10 V
Bridge supply voltage	+4.8...10.2 V
Bridge excitation	1 mV/V
(Declaration from manufacturer)	

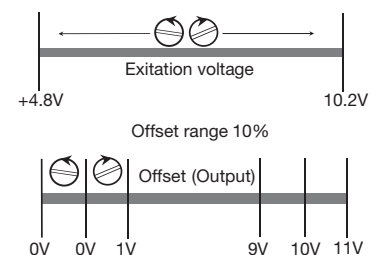

### Frequency Converter, 3-Way

- Three-way isolation
- Max. input frequency 100 kHz
- Input and output ranges adjustable using DIP switch
- 931S Configurator to assist with DIP switch selection, download at [www.ab.com](http://www.ab.com)
- No calibration necessary
- Special ranges can be programmed

#### 931S-F1C2D-DC

Specifications	<b>Frequency Converter, 3-Way</b>				
Wiring Diagram					
Standards Compliance	UL 508, UL 1604, CSA C22.2 No. 142-M1987, CSA C22.2 No. 213-1987, EN 50178:1997, EN 61000-6-1:2007, EN 61000-6-2: 2005, EN 61000-6-3:2007, EN 61000-6-4:2007				
Certifications	cULus (Class 1, Div. 2, Groups A, B, C and D, NRAG/7.E10314), CE				
<b>Input Ratings</b>					
Sensor	2-, 3-wire PNP/NPN, namur initiator, push-pull step				
Rated Input Level	Threshold / Hysteresis: Namur: approx. 1.7 mA/approx. 0.2 mA; NPN: approx. 6.5 V/approx. 0.2V; PNP: approx. 6.7V/approx. 0.5V				
Input Frequency	0...100 kHz				
Input	Active				
<b>Output Ratings</b>					
Voltage	0...10V				
Current	0...20 mA / 4...20 mA				
Load Impedance (voltage/current)	$\geq 1 \text{ k}\Omega / \leq 600 \Omega$				
Step Response Time	360 ms + 2-fold period of time of input frequency				
Temperature Coefficient	max. 200 ppm/ K of output range				
Accuracy	0.2% of output range				
Offset Current / Voltage	max. 100 $\mu\text{A}$ / max. 0.05V				
Status Indicator	green LED				
Output	Active				
<b>General Specifications</b>					
Supply Voltage	24V DC $\pm$ 25 %				
Power Consumption	max. 1.6 W at $I_{OUT} = 20 \text{ mA}$				
Current-carrying Capacity of Cross-Connect	$\leq 2 \text{ A}$				
Operating Temperature	0 °C...+55 °C				
Storage Temperature	-20 °C...+85 °C				
Default Settings	0...10 kHz / 4...20 mA				
Rated Insulation Voltage	300V				
Impulse Withstand Voltage	6 kV				
Isolation Voltage Input - Output	4kV <sub>eff</sub> / 5 s				
Surge Category	III				
Pollution Severity	2				
Connection Type	Screw				
L x W x D (mm)	92.4 x 12.5 x 112.4				
Signal Conditioner	<table border="1" style="width: 100%;"> <tr> <td style="text-align: center;">Cat. No.</td> <td style="text-align: center;">Pkg. Quantity</td> </tr> <tr> <td style="text-align: center;">931S-F1C2D-DC</td> <td style="text-align: center;">1</td> </tr> </table>	Cat. No.	Pkg. Quantity	931S-F1C2D-DC	1
Cat. No.	Pkg. Quantity				
931S-F1C2D-DC	1				

Selecting the operating mode		
Operating mode	Switch 2	
	3	4
0...fmax	<input type="checkbox"/>	<input type="checkbox"/>
fmin...fmax	<input type="checkbox"/>	<input checked="" type="checkbox"/>
saving	<input type="checkbox"/>	<input type="checkbox"/>
fmin	<input checked="" type="checkbox"/>	<input type="checkbox"/>

$$f = (A+B) \times C$$

Selecting the frequency					Selecting the frequency				
A	Switch 1				B	Switch 1			
	1	2	3	4		5	6	7	8
0	<input type="checkbox"/>	<input type="checkbox"/>	<input type="checkbox"/>	<input type="checkbox"/>	0	<input type="checkbox"/>	<input type="checkbox"/>	<input type="checkbox"/>	<input type="checkbox"/>
1	<input type="checkbox"/>	<input type="checkbox"/>	<input type="checkbox"/>	<input checked="" type="checkbox"/>	0.1	<input type="checkbox"/>	<input type="checkbox"/>	<input type="checkbox"/>	<input checked="" type="checkbox"/>
2	<input type="checkbox"/>	<input type="checkbox"/>	<input checked="" type="checkbox"/>	<input type="checkbox"/>	0.2	<input type="checkbox"/>	<input type="checkbox"/>	<input checked="" type="checkbox"/>	<input type="checkbox"/>
3	<input type="checkbox"/>	<input type="checkbox"/>	<input checked="" type="checkbox"/>	<input checked="" type="checkbox"/>	0.3	<input type="checkbox"/>	<input type="checkbox"/>	<input checked="" type="checkbox"/>	<input checked="" type="checkbox"/>
4	<input type="checkbox"/>	<input checked="" type="checkbox"/>	<input type="checkbox"/>	<input type="checkbox"/>	0.4	<input type="checkbox"/>	<input checked="" type="checkbox"/>	<input type="checkbox"/>	<input type="checkbox"/>
5	<input type="checkbox"/>	<input checked="" type="checkbox"/>	<input checked="" type="checkbox"/>	<input type="checkbox"/>	0.5	<input type="checkbox"/>	<input checked="" type="checkbox"/>	<input checked="" type="checkbox"/>	<input type="checkbox"/>
6	<input type="checkbox"/>	<input checked="" type="checkbox"/>	<input checked="" type="checkbox"/>	<input checked="" type="checkbox"/>	0.6	<input type="checkbox"/>	<input checked="" type="checkbox"/>	<input checked="" type="checkbox"/>	<input type="checkbox"/>
7	<input type="checkbox"/>	<input checked="" type="checkbox"/>	<input checked="" type="checkbox"/>	<input checked="" type="checkbox"/>	0.7	<input type="checkbox"/>	<input checked="" type="checkbox"/>	<input checked="" type="checkbox"/>	<input type="checkbox"/>
8	<input checked="" type="checkbox"/>	<input type="checkbox"/>	<input type="checkbox"/>	<input type="checkbox"/>	0.8	<input type="checkbox"/>	<input checked="" type="checkbox"/>	<input type="checkbox"/>	<input type="checkbox"/>
9	<input checked="" type="checkbox"/>	<input type="checkbox"/>	<input type="checkbox"/>	<input type="checkbox"/>	0.9	<input checked="" type="checkbox"/>	<input type="checkbox"/>	<input type="checkbox"/>	<input type="checkbox"/>
10	<input checked="" type="checkbox"/>	<input type="checkbox"/>	<input type="checkbox"/>	<input type="checkbox"/>					
11	<input checked="" type="checkbox"/>	<input type="checkbox"/>	<input checked="" type="checkbox"/>	<input type="checkbox"/>					
12	<input checked="" type="checkbox"/>	<input checked="" type="checkbox"/>	<input type="checkbox"/>	<input type="checkbox"/>					
13	<input checked="" type="checkbox"/>	<input checked="" type="checkbox"/>	<input type="checkbox"/>	<input type="checkbox"/>					
14	<input checked="" type="checkbox"/>	<input checked="" type="checkbox"/>	<input checked="" type="checkbox"/>	<input type="checkbox"/>					
15	<input checked="" type="checkbox"/>	<input checked="" type="checkbox"/>	<input checked="" type="checkbox"/>	<input checked="" type="checkbox"/>					

Selecting the frequency		
C	Switch 2	
	1	2
x1	<input type="checkbox"/>	<input type="checkbox"/>
x10	<input type="checkbox"/>	<input checked="" type="checkbox"/>
x100	<input checked="" type="checkbox"/>	<input type="checkbox"/>
x1000	<input checked="" type="checkbox"/>	<input checked="" type="checkbox"/>

Selecting the output				
Output	Switch 2			
	5	6	7	8
0...10 V	<input checked="" type="checkbox"/>	<input type="checkbox"/>	<input checked="" type="checkbox"/>	<input checked="" type="checkbox"/>
0...20 mA	<input type="checkbox"/>	<input type="checkbox"/>	<input type="checkbox"/>	<input type="checkbox"/>
4...20 mA	<input type="checkbox"/>	<input checked="" type="checkbox"/>	<input type="checkbox"/>	<input type="checkbox"/>
0...5 V	<input checked="" type="checkbox"/>	<input checked="" type="checkbox"/>	<input checked="" type="checkbox"/>	<input checked="" type="checkbox"/>

Special range (frequency generator is required)				
Function	Switch 2			
	1	2	3	4
save min. frequency	<input type="checkbox"/>	<input checked="" type="checkbox"/>	<input checked="" type="checkbox"/>	<input checked="" type="checkbox"/>
save max. frequency	<input type="checkbox"/>	<input type="checkbox"/>	<input checked="" type="checkbox"/>	<input checked="" type="checkbox"/>
select special range	<input checked="" type="checkbox"/>	<input checked="" type="checkbox"/>	<input checked="" type="checkbox"/>	<input checked="" type="checkbox"/>

■ = on  
 = off

#### Application

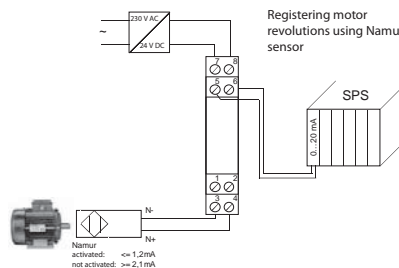



Bulletin 931  
**Signal Conditioners**  
**HART Signal Conditioner**

**Active Isolator, 3-Way, HART**

- Two conductor system
- Three port isolation
- With HART transmission
- Output signal switchable

**931H-A2C2D-DCHART**

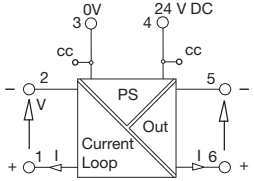
		
Specifications	<b>Active Isolator, 3-Way, HART</b>	
Wiring Diagram		
Standards Compliance	UL 508, CSA C22.2 No. 0-10, CSA C22.2 No. 14-10, EN 61010-1:2001, EN 61000-6-1:2007, EN 61000-6-2: 2005, EN 61000-6-3:2007, EN 61000-6-4:2007	
Certifications	cURus (NMTR2/8.E56639), CE	
<b>Input Ratings</b>		
Current	4...20 mA	
Sensor	2-conductor	
Supply Voltage	16.5V / constant for 3...22 mA	
Input	Active	
<b>Output Ratings</b>		
Current	0...20 mA / 4...20 mA	
Voltage	0...10V	
Load Impedance (voltage/current)	≥ 10 kΩ / ≤ 500 Ω	
Step Response Time	≤ 2 ms	
Temperature Coefficient	≤ 50 ppm/K	
Accuracy	I <sub>OUT</sub> : < 0.1% / U <sub>OUT</sub> : < 0.2%	
Offset Current / Voltage	max. 30 μA / max. 30 mV	
Residual Ripple	< 10 mV <sub>eff</sub>	
Output	Active	
<b>General Specifications</b>		
Supply Voltage	24V DC ± 15%	
Power Consumption	approx. 1 W	
Communication	to Hart specification	
Current Carrying Capacity of Cross Connect	≤ 2 A	
Operating Temperature	0 °C...+55 °C	
Storage Temperature	-25 °C...+85 °C	
Rated Insulation Voltage	600V	
Isolation Voltage Input - Output	2.5kV <sub>eff</sub>	
Surge Category	II	
Pollution Severity	2	
Connection Type	Screw	
L x W x H (mm)	88 x 6.1 x 97.8	
<b>Signal Conditioner</b>	Cat. No.	Pkg. Quantity
	931H-A2C2D-DCHART	1

**Setting options/switch position**

Output	Switch			
	1	2	3	4
4 ... 20 mA	<input type="checkbox"/>	<input type="checkbox"/>	<input checked="" type="checkbox"/>	<input type="checkbox"/>
0 ... 20 mA	<input checked="" type="checkbox"/>	<input type="checkbox"/>	<input checked="" type="checkbox"/>	<input type="checkbox"/>
0 ... 10 V	<input checked="" type="checkbox"/>	<input checked="" type="checkbox"/>	<input type="checkbox"/>	<input checked="" type="checkbox"/>

■ = on  
□ = off

**Passive Converter, Universal**

- Output loop powered
- Programmable with PC, download software on [www.ab.com](http://www.ab.com)
- Pluggable connection terminals
- Compact housing

**931U-C9A2C-OP**



Specifications	<b>Passive Converter, Universal</b>	
Standards Compliance	UL 61010B-1, CSA C22.2 No. 61010-1-2004, EN 50178:1997, EN 61000-6-1:2007, EN 61000-6-2: 2005, EN 61000-6-4:2007	
Certifications	cULus (PICQ/7.E345550), CE	
<b>Input Ratings</b>		
Type	Universal signal isolator/amplifier, thermocouple, RTD	
Type, Thermocouple	B / C / E / J / K / L / N / R / S / T / W3 / W5 -200...+ 2300 °C depending on thermocouple	
Type, RTD	PT100/ 200, Ni100, CU100 (all 2-, 3-, 4-wire) -200...+850 °C depending on RTD	
Current	-10...+20 mA (min. span 1 mA)	
Voltage	-5...+10 V / -100...+200 mV (min. span 0.5 V / 4 mV)	
Input Resistance (voltage/current)	2 MΩ/ 40 Ω	
Input	Passive	
<b>Output Ratings</b>		
Type	Current output	
Current	4...20 mA	
Residual Ripple	< 20 mV	
Step Response Time	Typically 200 ms (10...90%)	
Temperature Coefficient	Typically 0.02% / °C	
Load Resistance	[(Vs - 10) / 0.02] Ω (Typically 700 Ω @ 24V DC)	
Transmit Function	Linear, X <sub>1/2</sub> , X <sub>3/2</sub> , X <sub>5/2</sub> or user defined curve (101 points)	
Accuracy	Thermo: < ± 1%; RTD: < ± 0.5%; Resistance: < ± 0.1% of end value; DC < ± 0.1% of end value	
Output	Passive	
<b>General Specifications</b>		
Supply Voltage	10...40 V DC, powered by loop current	
Power Type	Output Loop Powered	
Operating Temperature	-10 °C...+70 °C	
Storage Temperature	-20 °C...+70 °C	
Long-term drift	0.1% / 10,000 h	
Cycle Time	20...200 ms	
Digital Filter Factor	1...100	
Interference Radiation	< ± 0.5%	
Rated Insulation Voltage	300V <sub>eff</sub>	
Impulse Withstand Voltage	4 kV (1.2/50 μs)	
Isolation Voltage	2 kV between ports	
Transmit Function	direct or reverse	
Connection Type	Screw	
L x W x D (mm)	92.4 x 12.5 x 112.4	
Signal Conditioner	Cat. No.	Pkg. Quantity
	931U-C9A2C-OP	1

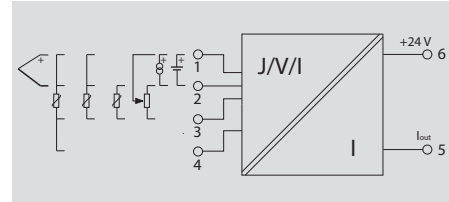

**Connections**

Terminal	Signal	
5	Loop -ve	Supply voltage
6	Loop +ve	
1	Signal + Power supply Sensor	Thermocouple
2	Signal + Power supply Storage (only for programming)	
1	A-Sense	4-wire PT100/RTD (or resistance)
3	A	
2	B	3-wire PT100/RTD (or resistance)
4	B-Sense	
1	A-Sense	2-wire PT100/RTD (or resistance)
3	A	
2	B	Voltage (mV or V)
3	A	
1	Signal +	Current (mA)
2	Signal -	
1	Wiper	Potentiometer
2	B	

**Bulletin 931**  
**Signal Conditioners**  
**Universal Signal Conditioner**

**Active Converter, 3-Way, Universal**

- Universal inputs
- Programmable with PC, download software on [www.ab.com](http://www.ab.com)
- Loop-powered or passive mA input
- AC or DC supply

**931U-C9C7C-BC**

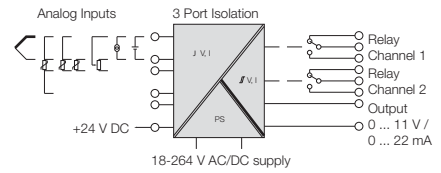

**Typical functions**

Specifications	<b>Active Converter, 3-way, Universal</b>	
Standards Compliance	UL 508, UL 1604, CSA C22.2 No. 142-M1987, CSA C22.2 No. 213-1987, EN 50178:1997, EN 60079-0:2006, EN 60079-15:2005, EN 61000-6-1:2007, EN 61000-6-2: 2005, EN 61000-6-3:2007, EN 61000-6-4:2007	
Certifications	cULus (Class 1, Div. 2, Groups A, B, C and D, NRAG/7.E10314), CE, ATEX (Class 1, Zone 2, DEKRA 11ATEX0015 X)	
<b>Input Ratings</b>		
Type, Thermocouple	B, E, J, K, L, N, R, S, T (IEC 60584)	
Type, RTD	PT100, PT1000, (EN 60571) Ni100, Ni1000, (JIS1604), Cu10, Cu25, Cu50, Cu100 (DIN 43760) 2-/3-/4-conductor	
Potentiometer	100 Ω...100 kΩ	
Resistance	10 Ω...5 kΩ	
Frequency	2 Hz...100 kHz	
Voltage	-200...500 mV (min. span 4 mV), -20...50V DC (min. span 0.5V)	
Current	-20...50 mA (min. span 0.4 mA)	
Sensor Supply	24V DC / 22 mA	
Input	Active or Passive	
<b>Output Ratings - Analog</b>		
Accuracy	< 0.1 % span (DC, RTD); 0.2 % span (or 1 °C) + CJ error	
Temperature Coefficient	< 0.1 % /K (DC, RTD); <0.1% FSR/K + CJ error 0.07 °C/K (Thermocouples)	
Voltage	-10...+10V (adjustable - min. span 2.5V)	
Current	0...20 mA (adjustable - min. span 5 mA)	
Output Signal During Wire Break	Configurable	
Load Resistance Voltage	> 10 kΩ @ 0...10V / > 20 kΩ @ -10...+10V	
Load Resistance Current	≤ 700 Ω	
Step Response Time	50 ms...1 sec (RTD, mV inputs), 110 ms...1 sec (V, mA inputs)	
Signal Output	Direct or inverted	
Transmit Function	Linear, X <sub>1/2</sub> , X <sub>3/2</sub> , X <sub>5/2</sub> or user-defined curve (101 points)	
<b>Output Ratings - Digital</b>		
Type	2 x 1 CO contact (hard gold plated)	
Max Switching Voltage	250V	
Continuous Current	3 A	
Output	Active	
<b>General Specifications</b>		
Supply Voltage	18...264V AC/DC	
Power Consumption	< 3.5 W	
Operating Temperature	-40 °C...+70 °C	
Storage Temperature	-40 °C...+85 °C	
Rated Insulation Voltage	300V	
Impulse Withstand Voltage	6 kV	
Isolation Voltage	2.5 kV	
Connection Type	Screw	
L x W x D (mm)	92.4 x 45 x 112.4	
Surge Category	III	
Pollution Severity	2	
<b>Signal Conditioner</b>	<b>Cat. No.</b>	<b>Pkg. Quantity</b>
	931U-C9C7C-BC	1

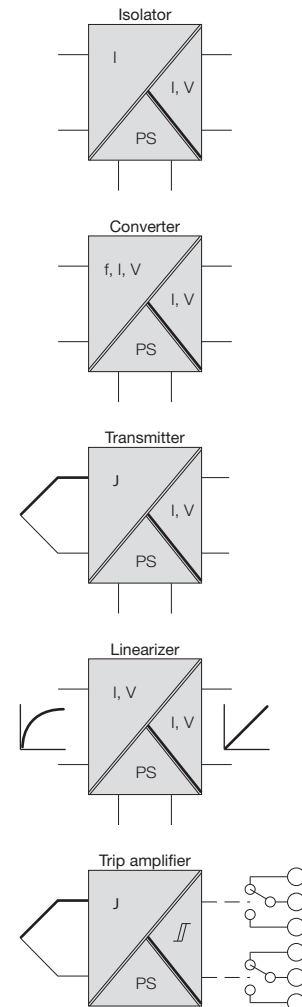

## Accessories

The table below indicates the accessories available for each signal conditioner.

Markers		Jumpers		End Barrier	Cable	Cat. No.
1492-M5X10	1492-M6X10	1492CJLJ5-2-*	1492-CJLJ6-*	931H-EB1	931U-CABLE	
<b>High-Density Signal Conditioners</b>						
	•		•			931H-A2A2N-DC
•			•			931H-A2C2D-DCHART
•			•			931H-C2C2D-DC
	•		•			931H-P2C1D-DC
	•		•			931H-T2C1D-DC
	•		•			931H-T1C1D-DC
	•		•	•		931H-A1A1N-IP
	•		•	•		931H-P2A2N-OP
<b>Standard Signal Conditioners</b>						
•						931S-A1A1N-IP1
•						931S-A1A1N-IP2
•						931S-A2A5N-OP
•		•				931S-A2A2N-DC
•		•				931S-A1A1N-DC
•						931S-C1A2D-OP
•						931S-C4C5D-BC
•		•				931S-P1C2D-DC
•		•				931S-T9C2D-DC
•		•				931S-F1C2D-DC
	•	•				931S-B1C6D-DC
	•	•				931S-A3C2D-DC
	•					931S-A3A2D-OP
		•				931S-A4C2D-DCHALL
	•					931S-V1R1D-MC1R
•		•				931S-C2R1D-DC2R
						931S-C3C3J-DC
<b>Universal Signal Conditioners</b>						
•					•	931U-C9A2C-OP
•					•	931U-C9C7C-BC

\* For size and color, please see product selection tables below.

### Snap-in Markers

Description	Markers Per Card	Marker Size	Pkg. Quantity	Cat. No.
Snap-in Markers	144	5 X 10 mm	5	1492-M5X10
Snap-in Markers	120	6 X 10 mm	5	1492-M6X10

### Plug-in Jumpers

Description	Color	Pkg. Quantity	Cat. No.
Plug-In Jumper, 2-pole, Yellow	Yellow	60	1492-CJLJ5-2
Plug-In Jumper, 2-pole, Red	Red	60	1492-CJLJ5-2-R
Plug-In Jumper, 2-pole, Blue	Blue	60	1492-CJLJ5-2-B
Plug-In Jumper, 2-pole, Black	Black	60	1492-CJLJ5-2-BL
Plug-In Jumper, 2-pole, Red	Red	60	1492-CJLJ6-2-R
Plug-In Jumper, 2-pole, Blue	Blue	60	1492-CJLJ6-2-B
Plug-In Jumper, 3-pole, Red	Red	60	1492-CJLJ6-3-R
Plug-In Jumper, 3-pole, Blue	Blue	60	1492-CJLJ6-3-B
Plug-In Jumper, 10-pole, Red	Red	20	1492-CJLJ6-10-R
Plug-In Jumper, 10-pole, Blue	Blue	20	1492-CJLJ6-10-B
Plug-In Jumper, 41-pole, Red	Red	10	1492-CJLJ6-41-R
Plug-In Jumper, 41-pole, Blue	Blue	10	1492-CJLJ6-41-B



Bulletin 931  
**Signal Conditioners**  
 Approximate Dimensions

**Approximate Dimensions**

Approximate dimensions are shown in inches (millimeters). Dimensions are not intended to be used for manufacturing purposes.

- 931H-A1A1N-IP
- 931H-P2A2N-OP

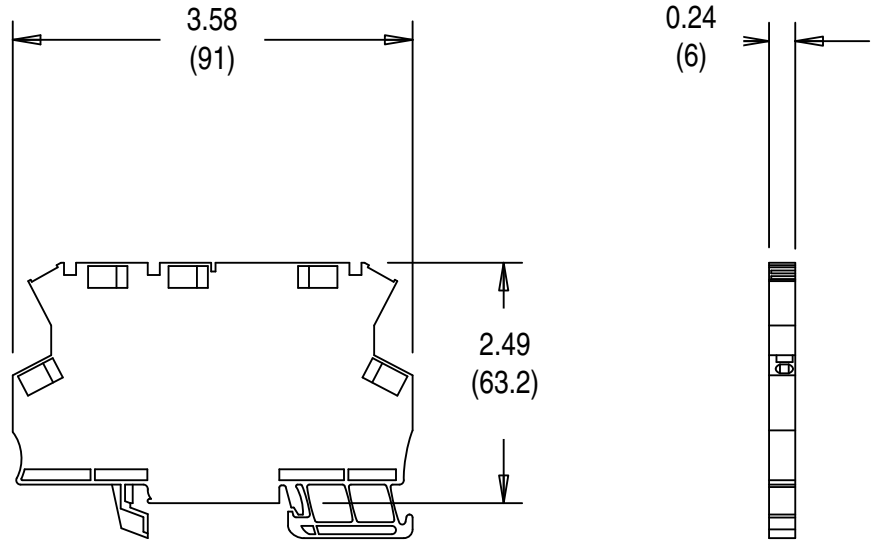

- 931H-A2A2N-DC
- 931H-A2C2D-DCHART
- 931H-C2C2D-DC
- 931H-P2C1D-DC
- 931H-T1C1D-DC
- 931H-T2C1D-DC

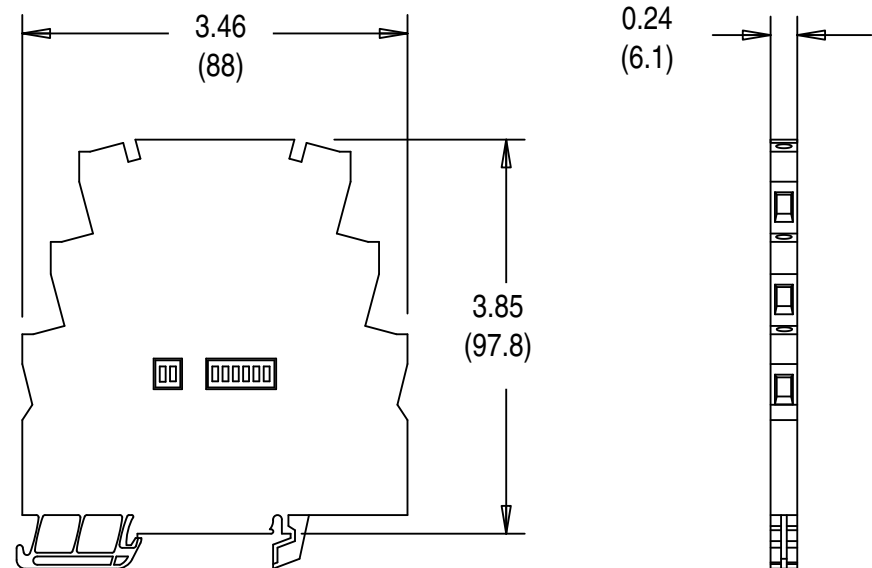

**Approximate Dimensions**

Approximate dimensions are shown in inches (millimeters). Dimensions are not intended to be used for manufacturing purposes.

- 931S-A2A2N-DC
- 931S-C3C3J-DC
- 931S-C4C5D-BC
- 931S-F1C2D-BC
- 931U-C9A2C-OP

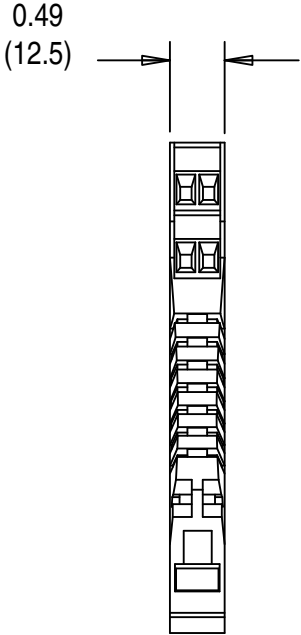
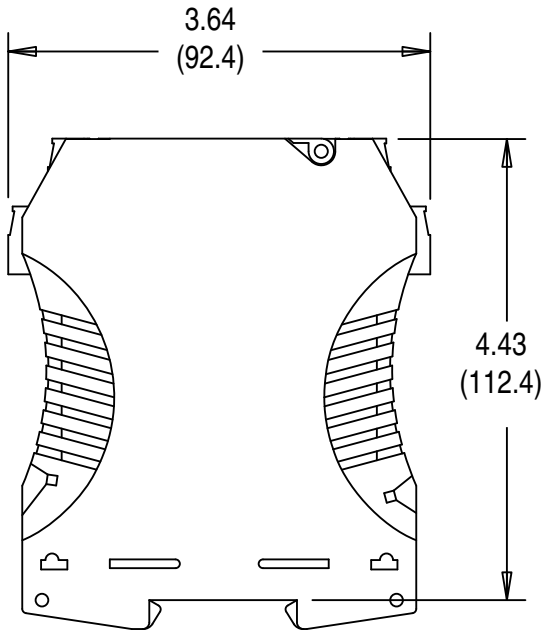

- 931S-B1C6D-DC
- 931S-C1A2D-OP
- 931S-C2R1D-DC2R
- 931S-P1C2D-DC
- 931S-A1A1N-DC
- 931S-A1A1N-IP1
- 931S-A1A1N-IP2
- 931S-A2A5N-OP
- 931S-T9C2D-DC
- 931S-V1R1D-MC1R

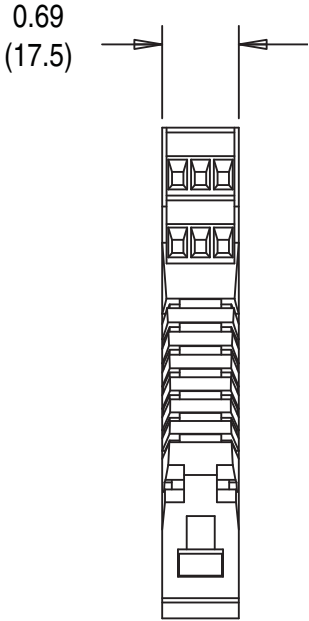
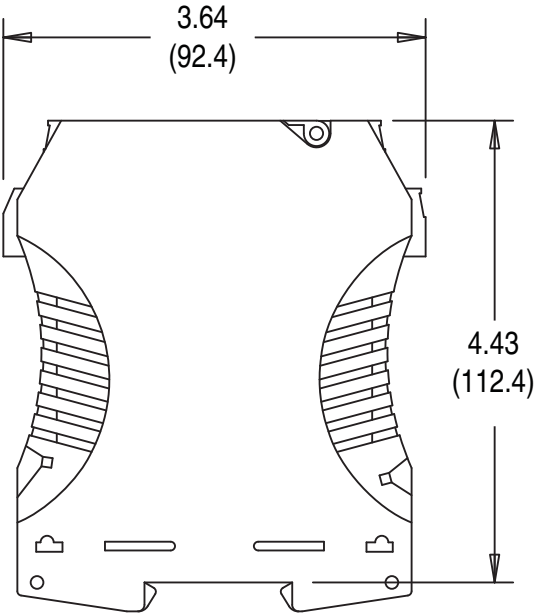

Bulletin 931  
**Signal Conditioners**  
 Approximate Dimensions

**Approximate Dimensions**

Approximate dimensions are shown in inches (millimeters). Dimensions are not intended to be used for manufacturing purposes.

- 931S-A3A2D-OP
- 931S-A3C2D-DC
- 931S-A4C2D-DCHALL

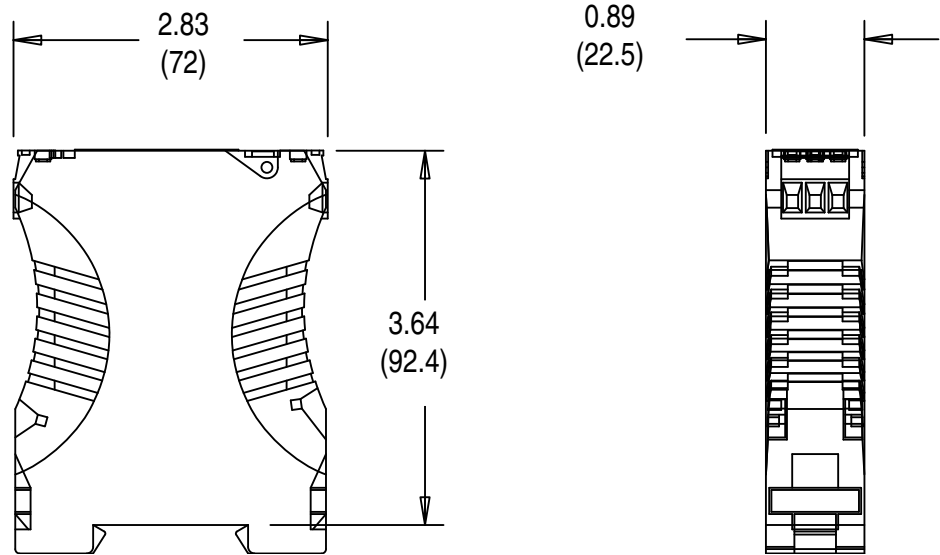

- 931U-C9C7C-BC

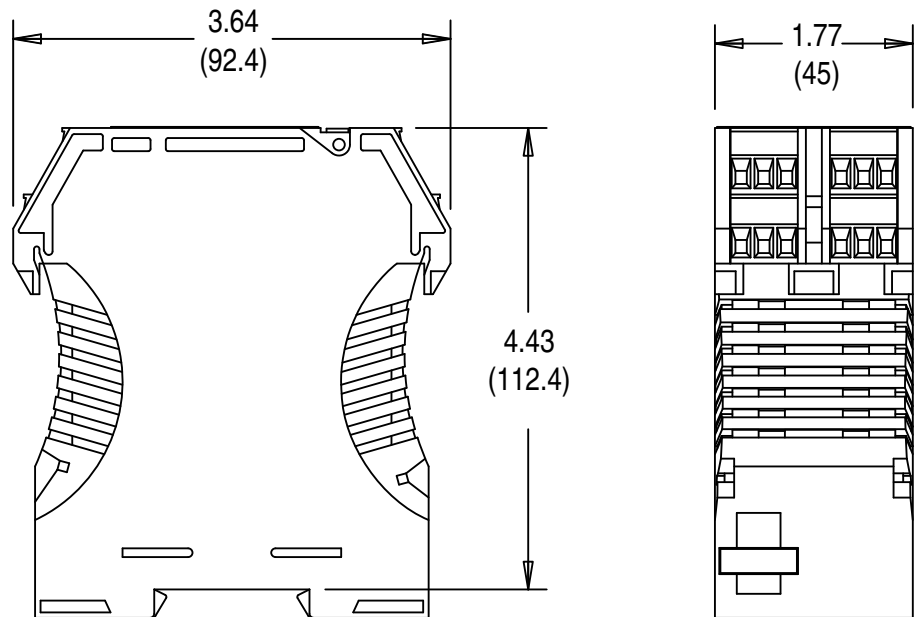

## Glossary

- 2-way Isolation** The input and output signals are separated electrically from each other and decoupled. Potential differences caused by long wire lengths and common reference points are eliminated.
- 3-way Isolation** The input, output and auxiliary power supply are separated electrically from each other and also decoupled. Potential differences caused by long wire lengths and common reference points are eliminated.

## A

- A/D Converter** Converts standardized analog current and voltage signals into an 8-bit, 12-bit or 16-bit digital signal. It may be necessary to convert analog signals into digital signals when you need the analog signal from the surroundings to work with the typical digital processing requirements of process monitoring.
- AC** Alternating current
- Accuracy** Describes the ability of an analog signal isolating converter to transmit a measured value as precisely as possible. It is specified in the percent deviation from the measuring range end value at room temperature.
- Active Input/Output** Refers to the input or output of a specific device and defines if the input or output is supplying power for the respective analog loop. Synonymous with sourcing.
- Active Converter** An active converter is used to provide electrical **isolation and conversion** between differing analog signal ranges. They are designed with 2-way or 3-way isolation. The isolation of the potentials eliminates interference on the measurement signal that can be caused by earth loops or common-mode noise. The active converter makes use of an auxiliary voltage source for its power supply. It functions without feedback; a change on the output side load does not influence the input circuit.
- Active Isolator** An active isolator is used to provide electrical **isolation** between the same analog signal range. They are designed with 2-way or 3-way isolation. The isolation of the potentials eliminates interference on the measurement signal that can be caused by earth loops or common-mode noise. The active isolator makes use of an auxiliary voltage source for its power supply. It functions without feedback; a change on the output side load does not influence the input circuit.
- Active Sensor** In an active sensor, an electrical signal is generated from the measurement itself, for example dynamometric or piezo-electric, thus no auxiliary power source is required. Because of their physical operating principals (since energy cannot be sent during the static and quasi-static states), only a change in the measured variable can be detected.
- Alarm Contact** A switching contact that activates when a disturbance occurs (for example, an overload or short circuit).
- Ambient Temperature** Refers to the temperature of the surrounding air or medium at which the equipment can be properly and safely operated. This is a part of the surrounding physical and operational conditions. Failure to maintain this temperature level can invalidate the product warranty.



**Analog Signal** A signal is designated as an analog signal if it transmits parameter information that is infinitely variable between a minimum and maximum value (this includes instantaneous values such as current, voltage or temperature). This applies to practically all real-world processes or states. It is theoretically possible to register any small signal changes (there is a very large dynamic range).

**ATEX** The ATEX directive from 23.4.1994 is valid within the EU and the EFTA Western European nations. It applies to devices, machinery components, controllers and protective systems that are to be used in hazardous areas. This directive harmonizes the different national regulations from the EU member nations concerning the proper and intended use of machines and facilities in hazardous areas.

- ATEX is derived from the phrase "ATmosphere EXplosive". It stipulates that operators should prevent explosions and ensure protection.
- Regarding explosion protection in a potentially explosive atmosphere, the ATEX directive 94/9/EC has precedence over machinery directives and must be followed. The directive describes the following steps:
- Describe how often a potentially explosive atmosphere occurs and where it occurs.
- These areas are then divided into zones according to the specifications.
- Make sure that only properly categorized equipment is present within each different zone. As soon as an area is classified as being dangerous, steps must be taken to limit the potential ignition sources that are present there.

## C

**CE** Abbreviation for Communauté Européenne (the European Community). Manufacturers use the CE label to confirm that their products comply with the corresponding EC directives and the "essential requirements" therein.

**Cold-junction Compensation** Thermocouples require a temperature reference point to compensate for unwanted "cold junctions". The usual method for achieving this is by measuring the temperature at the reference junction with a temperature sensor that can be read immediately. The interfering voltage can then be compensated for in the measurement results. This process is referred to as cold-junction compensation (CJC). Our thermocouple signal conditioners have cold-junction compensation to compensate for unwanted "cold-junctions" or temperature changes at the terminal connection for the thermocouple.

**Common-Mode Interference** Interfering currents and voltages that can occur on the connecting cables between electrical devices and facility components. These can then spread with similar phase and current direction to the feed line and the return line.

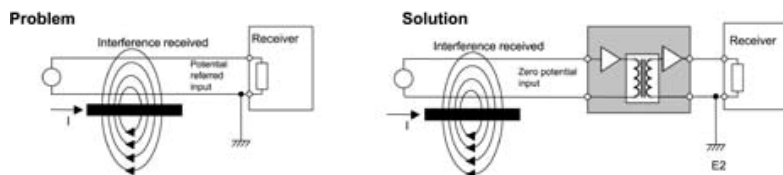

**Creepage and Clearance Distances** The safety gaps between two current-carrying wires. The creepage distance is the shortest path along an insulating surface between two live components. The clearance distance is the shortest path in the air between two points of reference.

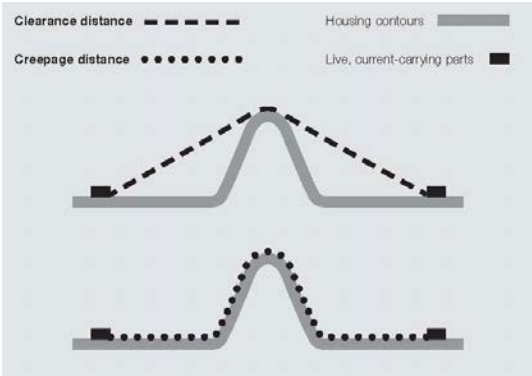

**D**

**D/A Converter** D/A converters convert standardized digital signals (for example, with an 8-bit structure) into analog current and voltage signals.

It may be necessary to convert digital signals into analog signals when you need the analog signal from the surroundings to work with the typical digital processing requirements of process monitoring.

**DC** Direct current

**De-rating** The continuous current level reduction in relation to an ambient temperature increase, represented as a de-rating curve (a load reduction curve).

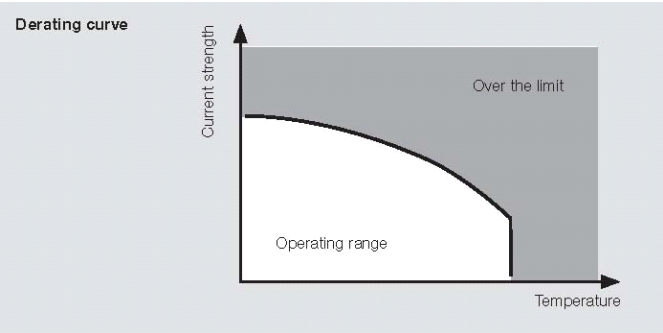

## E

**Earth (Ground) Loops** A main cause of error in process systems comes from earth loops. An earth loop occurs when two or more circuits are connected to each other and referenced to earth or a reference point. This reference point usually does not have the identical electrical potential at each position. When the two ends of the line are earthed at two different positions, the voltage differential between the two earth potentials on the line can lead to a compensating current that may corrupt analog measurement signals. This occurs when field sensors have a separate earth or separate power feed. Analog signal isolation amplifiers use electrical isolation to separate the input and output circuits thus preventing the measurement signal from being corrupted.

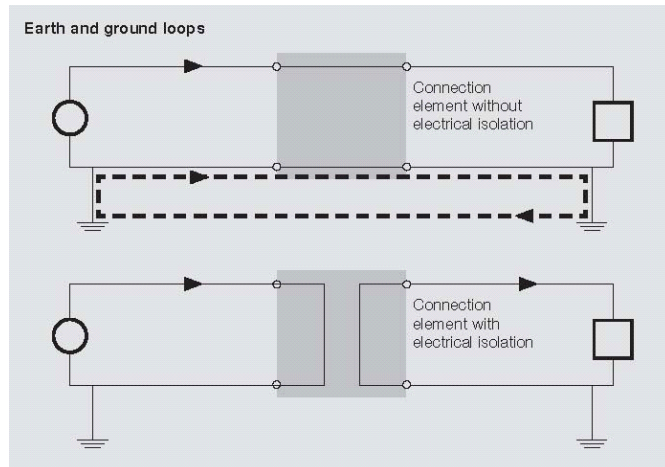

**Electrical Equipment** All of the electrical and electronic components and circuits within an enclosure.

## F

**Frequency Converter** Converts frequencies into analog signals. In-line control systems can then directly process pulse strings from speed or rotational measurements.

## G

**Galvanic Isolation** Potential-free isolation between electrical components. Normally, the input circuit, output circuit and power supply are designed so that they are electrically isolated from each other. The isolation can be achieved using optical means (an optocoupler) or by using a transformer. The electrical isolation of measurement signals ensures that the differences in earth potentials and common-mode interference are suppressed

**Ground Loop** See 'Earth Loop.'

H

**Hall Sensor Current Measurement** Hall sensors can measure the magnetic field of a conducting wire. They then generate a proportional voltage on the measurement output (the Hall voltage). This can be converted to a standardized signal by means of an amplifier circuit. Such a measurement is well suited for measuring high DC and AC currents with frequencies up to 1 kHz. Start-up currents and current peaks cannot damage a Hall sensor.

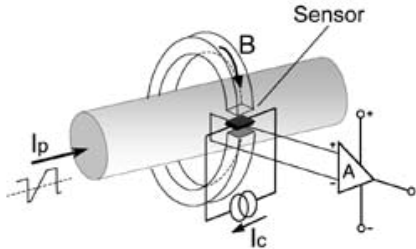

**HART®** HART® (Highway Addressable Remote Transducer) is a communications protocol for bus-addressed field devices used in process automation. In HART®-based communications, field devices and controllers are connected together over 4-20 mA current loops. This analog signal is superimposed with a digital signal by using the FSK process (Frequency Shift Keying). The process allows additional measurements, configuration and device data to be transmitted without influencing the analog signal. HART®.

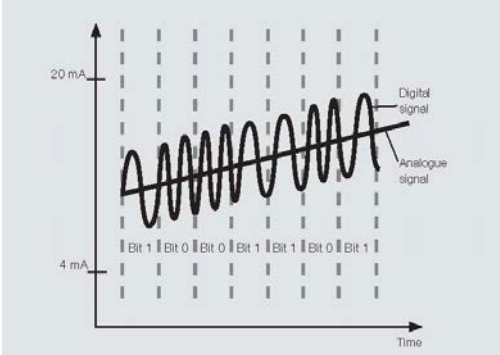

**Hysteresis** Specifies the percent difference between the switch-on and switch-off points of a switching contact. The hysteresis must not fall below a minimal value. Otherwise it would no longer be possible to carry out specific switching during the monitoring of threshold.

I

**Impulse Withstand Voltage** The high pulse voltage of a specified form and polarity that does not lead to an insulation breakthrough or flashover, under the specific conditions defined in EN 60664-1.

**Initiator PNP/NPN Switched** Two wires in a three-wire sensor are responsible for keeping the supply activated. The third connecting wire is used for transferring commands (NO/NC contact). Initiators with NPN outputs switch the load in active mode towards the minus potential. Proximity switches with PNP outputs switch toward the plus potential.

- Input Loop-Powered** Input loop powered equipment is 2-wire and has a 4 - 20 mA input. The equipment is supplied with power via the current loop on the input side.
- Insulation Voltage** For electronics components with electrical isolation, this is the maximum AC test voltage that can be applied for a specified time interval (5 s / 60 s) without causing a break-through.
- Isolation Amplifier** See ' Active Isolator.'

## L

- Leakage Current** The current on the load side of an optocoupler, Triac, transistor, or any other electronic switching device that flows towards the output circuit while in a closed state.
- Limiting Frequency** The limiting frequency of an analog signal isolating converter is that frequency where the output signal is reduced to  $1/(\sqrt{2})$  of the value of the input signal (approx. 70.7 % = -3 dB).
- Line Break Monitoring** Analog measuring transducer with wire-break detection capability that permanently monitors the input signal. In the event of an fault (a wire break), the output signal jumps up to a defined value over the nominal range so that a controller wired further down the circuit can evaluate the error.
- Linearization** Temperature-dependent components normally do not have a linear characteristic curve. Their characteristic curves must be linearized so that they can be evaluated as precisely as possible. The measurement curves of thermocouples and temperature-dependent resistors (NTC/ PTC), in particular, exhibit significant deviation from an "ideal curve". In the linearization process, the measurement signal is processed by a microprocessor and an ideal characteristic curve is generated which can then be analyzed or processed further.
- Load Cell** A load cell is a special type of force sensor used in weighing systems (i.e., with scales). Load cells usually have a spring mechanism used as a force sensor. The spring is a specially shaped piece of metal whose shape changes slightly when under the influence of weight. This elastic deformation is recorded by strain gauges and converted into an electrical signal. Weights can be recorded ranging from a few hundred grams to several thousand tons.
- Load Resistance (Load)** This is the load resistance on the output side of a measuring transducer or transmitter. For analog current outputs, the load is 500-600 ohms maximum. Voltage outputs normally have a load of at least 10 kOhm.

## M

- Measurement Isolating Transformer** Converts electric and non-electric input signals into standard analog signals. At the same time it provides electrical isolation between the input and output (2-way isolation) or between the input, output and supply (3-way isolation). Measurement isolators are typically used to record temperatures (RTD, thermocouples) or for measuring current, voltage, power, frequency, resistance and conductivity.
- Measuring Bridge** Sensors based on Wheatstone bridge circuitry can capture force, pressure and torque. Relatively small length changes under 10 - 4 mm can be recorded using DMS strain gauges in the form of resistance changes. A typical application is for capturing measurements in load cells.

## N

**Namur Sensor** NAMUR-compliant sensors (The standardization commission for measuring and control technology in the German chemical industry) operate with a load-independent current. They have four modes so that an analog evaluative unit can detect a sensor malfunction.

- 1) Current of 0 mA => wire break, circuit is open
- 2) Current of approx. 20 % of the max. value => Sensor ready, activated
- 3) Current of approx. 60 % of the max. value => Sensor ready, not activated
- 4) Current at max. value => short circuit, max. current

NAMUR sensors are suited for use in hazardous areas.

**Nominal Switching Current -Load Side** The permitted load current of a relay contact or semiconductor contact when in continuous operations.

**Nominal Switching Voltage - Load Side** The switching voltage that a relay contact or semiconductor contact uses in relation to its application.

## O

**Output Loop-Powered** Output loop powered 2-wire devices have a 4 - 20 mA output. The device is supplied with power via the current loop on the output side.

- Overvoltage Category** The overvoltage categories are described in DIN EN 60664-1. The category dictates the insulation clearance gaps required. Category III is the default specification (EN 50178).
- Overvoltage category I: Devices that are intended to be connected to the permanent electrical building installation. The measures for limiting transient surge voltages to the proper level are taken outside of the device. The protective mechanisms can either be in the permanent installation or between the permanent installation and the device.
  - Overvoltage category II: Devices that are intended to be connected to the permanent electrical building installation (such household appliances or portable tools).
  - Overvoltage category III: Devices that are a part of the permanent installation and other devices where a higher degree of availability is required. This includes the distributor panels, power switches, distribution systems (including cable, busbars, distributor boxes, switches and outlets) that are part of the permanent installation, devices intended for industrial use, and devices that are continually connected to the permanent installation (such as stationary motors).
  - Overvoltage category IV: Devices that are intended to be used on or near the power feed in a building's electrical installation - ranging from the main distribution to the mains power system. This includes electrical meters, surge protection switches and ripple control equipment.

## P

- Passive Input/Output** Refers to the input or output of a specific device. Synonymous with sinking, which means does NOT supply power for the respective analog loop.
- Passive Converter** This device is powered by either its input or output analog loop and provides electrical **isolation and conversion** to differing analog signal ranges. The amount of current needed internally is so small that the measurement signal is not influenced. Passive converters do not require an auxiliary voltage supply. Transformers are used to provide the isolation between the input and the output. The advantages include: eliminates the influence of the mains power system, highly accurate, minimal signal delay, and minimal power used. Passive converters do not function free from feedback; so a load change on the output circuit will automatically affect the input circuit as well.
- Passive Isolator** This device is powered by either its input or output analog loop and provides electrical **isolation** between the same analog signal range. The amount of current needed internally is so small that the measurement signal is not influenced. Passive converters do not require an auxiliary voltage supply. Transformers are used to provide the isolation between the input and the output. The advantages include: eliminates the influence of the mains power system, highly accurate, minimal signal delay, and minimal power used. Passive isolators do not function free from feedback; so a load change on the output circuit will automatically affect the input circuit as well.
- Passive Sensor** Contains passive components whose parameters can be changed by the measured variables. A primary electronic mechanism converts these parameters into electric signals. An auxiliary external power source is needed for the passive sensor. Passive sensors can be used to determine both static and semi-static measured variables. For this reason, the majority of sensors have a passive construction. Examples of this type include load cells and resistance thermometers.

**Pollution Severity Level** The pollution severity level specifies the conditions of the immediate surroundings. It is defined in DIN EN 50178, Section 5.2.15.2.

The pollution (contamination) severity level should be used to determine the required creepage distance for the insulation. Pollution degree 2 is the default specification.

- Pollution severity level 1: There is no contamination or only dry occurrences of non-conductive pollution. This pollution has no influence.
- Pollution severity level 2: There is only non-conductive pollution. Temporary occurrences of conductivity caused by condensation may also occur.
- Pollution severity level 3: Conductive pollution or dry, non-conductive pollution that can become conductive due to condensation is likely to occur.
- Pollution severity level 4: The contamination leads to continual conductivity which can be caused by such contaminants as conductive dust, rain or snow.

## R

**Rated Voltage** Specified by the insulation coordination - the rated voltage is the voltage level at which the product can be safely operated, in relation to the corresponding pollution severity level and the surge voltage category.

**Relative Humidity** The relationship between the actual moisture and the maximum possible quantity of water in the air. Expressed as a percentage.

**RoHS** The EC directive 2002/95/EC - concerning the restriction of the use of certain hazardous substances in electrical and electronic equipment - regulates the use of hazardous materials within devices and components. This directive, and its various implementations into national laws, are referred to by the abbreviation RoHS (Restriction of Hazardous Substances).

**RTD/ PT100/ 1000** RTD sensors are temperature probes that operate based on the resistance changes which take in metal as the temperature changes. They are resistance thermometers based on PTC resistors. The electrical changes in resistance of a platinum wire or platinum film is often used for measuring temperatures ranging from -200 °C to 850 °C. The platinum temperature sensors are characterized by their nominal resistance R0 at a temperature of 0 °C. The standard types include:

- Pt100 (R0= 100 Ohm)
- Pt1000 (R0= 1 kOhm)

A two-wire, three-wire or four-wire electrical connection can be used to electrically connect the PT/RTD sensor to the evaluative electronics. A three-wire or four-wire method eliminates any errors caused by the inherent resistance of the sensor connecting wires.

In the three-wire method, one end is equipped with two pigtail connectors. In the four-wire method, both ends are equipped with two pigtail connectors.



**S**

- Sensor** A sensor is a physical component capable of capturing certain physical or chemical properties (such as thermal radiation, temperature, humidity, pressure, noise, brightness or acceleration) as a measurement. It may also be able to analyze the quality of the composition of the material surroundings. These values are captured using physical or chemical phenomena and then converted into another form (usually electrical signals) so they can be post-processed.
- Signal Splitter** A signal isolator that accepts an analog input signal and delivers at least two isolated and independent signals on the output side. This permits the signal to be transmitted to a PLC/DCS system and to a separate display. A signal multiplier is designed either as an active isolator with an external power feed or as an output loop powered version.
- SIL** Safety Integrity Level. The components must meet the requirements of IEC 61508 in order to reduce risk. This standard provides general requirements for avoiding and minimizing device and equipment outages. It stipulates organization and technical requirements concerning device development and operation. Four safety levels are defined (from SIL1 for minimal risk to SIL4 for very high risk) for classifying facilities and risk-reduction measures. Risk-reduction measures must be more reliable when the classified risk level is higher.
- Status Indicator** An LED that displays the operational status, such as operational (yellow), switching (green), and alarm/malfunction (red).
- Step Response Time** This is the time delay in the output signal change when there is a signal jump ranging from 10 to 90 % on the input side. The step response time is inversely proportional to the limiting frequency.
- Storage Temperature** The permitted ambient temperature, related to a specific relative humidity level, for which the product should be stored while in a current-free state.
- Switching Threshold** The switch-on or switch-off point.

**T**

- Temperature Coefficient** The temperature coefficient describes the relative change of a physical variable based on the temperature change relative to a reference temperature (room temperature). It directly influences the precision of an analog signal converter. The coefficient is specified in ppm/K of the corresponding measuring range end value.

**Thermocouple** A thermocouple is a component made of two different materials which are connected to each other at one end. An electrical voltage is created (based on the principle of the Seebeck effect) along a wire that connects the unattached ends when there is a temperature differential.

The juncture point and the unattached ends must have different temperatures for a voltage to be generated.

The following thermocouples are used for industrial applications:

Thermal pair	Short name	Type	Temperature range in °C
Nickel/Chrome-Nickel/Al	NiCr-Ni/Al	K	-200 ... +1372
Iron-constantan	Fe-CuNi	J	-200 ... +1200
Copper-constantan	Cu-CuNi	T	-200 ... +400
Nickel/Chrome-constantan	NiCr-CuNi	E	-200 ... +1000
Platinum/10% Rhodium-Platinum	Pt10Rh-Pt	S	-50 ... +1760
Platinum/13% Rhodium-Platinum	Pt13Rh-Pt	R	-50 ... +1760
Nickel/Chrome-Nickel/Magnesium	NiCr-NiMg	N	-200 ... +1300
Platinum/30% Rhodium - Platinum/6% Rhodium	Pt30Rh - Pt6Rh	B	0 ... +1820

**Threshold Monitoring** The limiting values of physical variables must be continually monitored for industrial processes. This includes fill levels, temperatures, speed, positions, weights and frequencies. Specialized threshold monitoring components are used for this purpose. The sensor signals are captured on the input side, evaluated electronically and converted. The corresponding threshold (min/max) is then made available via the digital switching outputs (relays or transistors) to the external devices. Potentiometers can be used to customize each switching point and its minimum/maximum threshold as well as the switching hysteresis.

**Transformer-Based Current Measurement** Signal converters with transformer coupling are used for taking cost-effective measurements of sinusoidal currents (50/60 Hz). The current being measured flows directly through the primary coil of the measurement transformer. It is then stepped down and electronically processed in the converter.

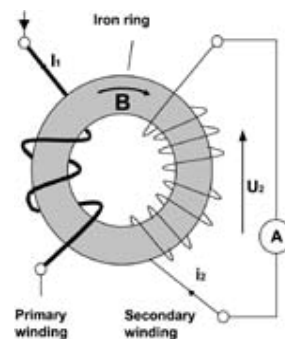

**Type of Contact** A contact is called normally open (NO) or a make contact if it is open when the armature is dropped out (no current in coil) and closed when the armature is picked up (current flowing in coil). A contact is called a break contact or normally closed (NC) contact if it interrupts the circuit when the armature is picked up. A combination of NC and NO is called a changeover (CO) contact. A relay may have one or more of such contacts.

**Notes:**



**[www.rockwellautomation.com](http://www.rockwellautomation.com)**

---

**Power, Control and Information Solutions Headquarters**

Americas: Rockwell Automation, 1201 South Second Street, Milwaukee, WI 53204 USA, Tel: (1) 414.382.2000, Fax: (1) 414.382.4444

Europe/Middle East/Africa: Rockwell Automation, Vorstlaan/Boulevard du Souverain 36, 1170 Brussels, Belgium, Tel: (32) 2 663 0600, Fax: (32) 2 663 0640

Asia Pacific: Rockwell Automation, Level 14, Core F, Cyberport 3, 100 Cyberport Road, Hong Kong, Tel: (852) 2887 4788, Fax: (852) 2508 1846