

PowerFlex 70 Adjustable Frequency AC Drive

This document explains the 5 BASIC STEPS to install and perform a Basic Start-up of the PowerFlex® 70 AC drive. A human interface module (HIM) is required to perform the Basic Start-up routine that is covered in this manual.

The information that is provided in this manual is intended for qualified installers only.

Summary of Changes

This manual contains new and updated information as indicated in the following table.

Topic	Page
Added Bulletin 140MT Motor Protection Circuit Breakers to Drive Input Protection Devices	Throughout
Updated Rockwell Automation support URLs	Throughout



Additional Resources

These documents contain more information for related products from Rockwell Automation®.

Resource	Description
Motor Protection Circuit Breaker and Motor Circuit Protector Specifications, publication 140-TD005	Provides product selection and specification information for Bulletin 140MP/MT and 140M-F motor protection circuit breakers and motor circuit protectors.
PowerFlex 70 AC Drives Technical Data, publication 20A-TD001	This publication provides detailed drive specifications, option specifications, and input protection device ratings.
PowerFlex 70 Adjustable Frequency AC Drive User Manual, publication 20A-UM001	Provides the basic information to start-up and troubleshoot the PowerFlex 70 Adjustable Frequency AC Drive.
DriveGuard® Safe Torque Off Option (Series B) for PowerFlex 40P and PowerFlex 70 AC Drives, publication PFLEX-UM003	Provides information for the installation and operation of the DriveGuard Safe Torque Off option.
PowerFlex Communication Adapter User Manuals, publication 20COMM-UMxxx (Adapter-specific user manual)	Provides information for the installation and operation of the various communication protocol adapters available for the drive.
Dynamic Braking Resistor Calculator, publication PFLEX-AT001	Provides information for determining dynamic braking requirements and evaluating resistors for dynamic braking.
PowerFlex 70 and 700 Reference Manual - Volume 1, publication PFLEX-RM001	Provides detailed information for specifications and dimensions, operation, and dynamic brake selection for the drive.
PowerFlex 70 EC and 700 VC Reference Manual, publication PFLEX-RM004	Provides detailed drive information including operation, parameter descriptions, and programming.
Wiring and Grounding Guidelines for Pulse Width Modulated (PWM) AC Drives, publication DRIVES-IN001	Provides the basic information to properly wire and ground Pulse Width Modulated (PWM) AC drives.
Industry Installation Guidelines for Pulse Width Modulated (PWM) AC Drives, publication DRIVES-AT003	Provides basic information for enclosure systems and environmental/location considerations (to help protect against environmental contaminants), and power and grounding considerations to properly install AC drives.
Product Certifications website, rok.auto/certifications	Provides declarations of conformity, certificates, and other certification details.

You can view or download publications at rok.auto/literature. To order paper copies of technical documentation, contact your local Allen-Bradley distributor or Rockwell Automation sales representative.

Table of Contents

Topic	Page
Catalog Number Explanation	4
Step 1: Read the Precautions and General Information	5
Step 2: Mount the Drive – Minimum Requirements	8
Minimum Mounting Clearances	8
Power Ratings, Dimensions, and Approximate Weights	9
Step 3: Wire the Drive – Wire Recommendations	15
Opening the Cover	15
IP66 NEMA/UL Type 4X/12 Indoor Installations	15
AC Supply Source Considerations	16
Power Terminal Block	17
General Grounding Requirements	19
Power Wiring	20
Electronic Motor Overload Protection	21
Drive, Fuse, and Circuit Breaker Ratings	22
Disconnecting MOVs and Common Mode Capacitors	26
Step 4: I/O Wiring	31
I/O Terminal Positions	32
I/O Wiring Examples	33
Hardware Enable Circuitry	35
Safe Torque Off Board Option	35
Encoder Interface Option	36
Step 5: Start-up Checklist	37
Prepare For Drive Startup	37
Information About Start-up Motor Tests	38
Appendix A: Startup and Troubleshooting	39
First Power-up Menu Structure	39
Human Interface Module (HIM) Overview	40
Start-up Routines	42
Running S.M.A.R.T. Start	43
Running an Assisted Startup	43
Drive Status Indicators	44
Common I/O Programming Changes	44
Control Scheme	44
Restoring Factory Defaults	44
Troubleshooting – Abbreviated Fault and Alarm Listing	45
Common Symptoms and Corrective Actions	47
Manually Clearing Faults	48

Catalog Number Explanation

1...3 4 5...7 8 9 10 11 12 13 14 15 16
20A B 2P2 A 3 A Y Y N N C O
a a b c d e f c3 g h i j k l c5

Drive	
Code	Type
20 A	PowerFlex 70

Voltage Rating		
Code	Voltage	Ph.
B	240V AC	3 (six pulse)
C	400V AC	3 (six pulse)
D	480V AC	3 (six pulse)
E	600V AC	3 (six pulse)

PowerFlex 70 ND Rating				
208V, 60 Hz Input				
Code	208V amps	kW	Hp	Frame
2P2	2.5	0.37	0.5	A
4P2	4.8	0.75	1.0	
6P8	7.8	1.5	2.0	B
9P6	11	2.2	3.0	
015	17.5	4.0	5.0	C
022	25.3	5.5	7.5	
028	32.2	7.5	10	D
042	43	11	15	
054	56	15	20	E
070	78.2	18.5	25	

PowerFlex 70 ND Rating				
240V, 60 Hz Input				
Code	Amps	kW	Hp	Frame
2P2	2.2	0.37	0.5	A
4P2	4.2	0.75	1.0	
6P8	6.8	1.5	2.0	B
9P6	9.6	2.2	3.0	
015	15.3	4.0	5.0	C
022	22	5.5	7.5	
028	28	7.5	10	D
042	42	11	15	
054	54	15	20	E
070	70	18.5	25	

Internal Brake Resistor	
Code	w/ Resistor
Y	Yes
N	No

Comm Slot	
Code	Network Type
C	ControlNet (Coax)
D	DeviceNet
E	EtherNet/IP
N	None

PowerFlex 70 ND Rating				
400V, 50 Hz Input				
Code	Amps	kW	Hp	Frame
1P3	1.3	0.37	0.5	A
2P1	2.1	0.75	1.0	
3P5	3.5	1.5	2.0	
5P0	5.0	2.2	3.0	B
8P7	8.7	4.0	5.0	
011	11.5	5.5	7.5	C
015	15.4	7.5	10	
022	22	11	15	D
030	30	15	20	
037	37	18.5	25	
043	42	22	30	
060	60	30	40	E
072	72	37	50	

PowerFlex 70 ND Rating				
480V, 50 Hz Input				
Code	Amps	kW	Hp	Frame
1P1	1.1	0.37	0.5	A
2P1	2.1	0.75	1.0	
3P4	3.4	1.5	2.0	
5P0	5.0	2.2	3.0	B
8P0	8.0	3.7	5.0	
011	11	5.5	7.5	C
014	14	7.5	10	
022	22	11	15	D
027	27	15	20	
034	34	18.5	25	
040	40	22	30	
052	52	30	40	E
065	65	37	50	

Emission Class	
Code	Rating
A	Filtered ⁽¹⁾ A ⁽²⁾ & B Frames (Optional) C, D, & E Frames (Standard)
N	Not Filtered ⁽¹⁾ A & B Frames (Optional) C, D, & E Frames (Standard)

- (1) 600V Frames A...D available only without filter (Cat. Code N). 600V Frame E available with filter (Cat. Code A).
- (2) Increases size to Frame B.

Control and I/O		
Code	Control	Safe Torque Off
N ⁽¹⁾	Standard	—
C	Enhanced	No
G	Enhanced	Yes

- (1) No longer available for sale.

PowerFlex 70 ND Rating				
600V, 60 Hz Input ⁽¹⁾				
Code	Amps	kW	Hp	Frame
0P9	0.9	0.37	0.5	A
1P7	1.7	0.75	1.0	
2P7	2.7	1.5	2.0	
3P9	3.9	2.2	3.0	B
6P1	6.1	4.0	5.0	
9P0	9.0	5.5	7.5	C
011	11	7.5	10	
017	17	11	15	D
022	22	15	20	
027	27	18.5	25	
032	32	22	30	
041	41	30	40	E
052	52	37	50	

- (1) 600V class drives are declared to meet the Low Voltage Directive. It is the responsibility of the user to determine compliance to the EMC Directive.

Enclosure	
Code	Enclosure
A ⁽¹⁾	Panel Mount - IP 20, NEMA/UL Type 1
C ⁽¹⁾	Wall/Machine Mount = IP66, NEMA/UL Type 4X/12 for indoor use only
F	Flange Mount - Front Chassis = IP 20, NEMA/UL Type 1; Rear Heat sink = IP66, NEMA/UL Type 4X/12 for indoor use only
G	Wall/Machine Mount - IP54, NEMA/UL Type 12 ⁽²⁾

- (1) IP20 and IP66 frame E drives are manufactured with a flange-like heat sink with mounting holes.
- (2) Only available on Frame E.

HIM	
Code	Interface Module
0	Blank Cover
3	Full Numeric LCD
5	Prog. Only LCD ⁽¹⁾

- (1) Only available with NEMA 4X, enclosure C.

Documentation	
Code	Type
A	Manual
N	No manual

Brake IGBT	
Code	w/Brake
Y	Yes

Feedback ⁽¹⁾	
Code	Feedback
0	No Feedback - Enhanced Control
1	5V/12V Encoder w/Enhanced Control

- (1) Drive is not CE EMC certified when the encoder interface option is installed.

Step 1: Read the Precautions and General Information

Qualified Personnel



ATTENTION: Only qualified personnel familiar with adjustable frequency AC drives and associated machinery can plan or implement the installation, startup, and subsequent maintenance of the system. Failure to comply can result in personal injury and/or equipment damage.

Personal Safety



ATTENTION: To avoid an electric shock hazard, verify that the voltage on the bus capacitors has discharged before performing any work on the drive. Measure the DC bus voltage at the +DC terminal of the Power Terminal Block and the -DC test point (refer to [Frame A, B, C, D Power Terminal Block, and DC Bus Test Points](#) on page 19 for location). The voltage must be zero.



ATTENTION: Risk of injury or equipment damage exists. DPI™ or SCANport™ host products must not be directly connected together via 1202 cables. Unpredictable behavior can result if two or more devices are connected in this manner.



ATTENTION: The drive start/stop/enable control circuitry includes solid-state components. If hazards due to accidental contact with moving machinery or unintentional flow of liquid, gas or solids exist, an additional hard-wired stop circuit may be required to remove the AC line to the drive. An auxiliary braking method may be required.

Product Safety



ATTENTION: An incorrectly applied or installed drive can result in component damage or a reduction in product life. Wiring or application errors, such as, undersizing the motor, incorrect or inadequate AC supply, or excessive ambient temperatures can result in malfunction of the system.



ATTENTION: This drive contains ESD (Electrostatic Discharge) sensitive parts and assemblies. Static control precautions are required when installing, testing, servicing, or repairing this assembly. Component damage can result if ESD control procedures are not followed. If you are not familiar with static control procedures, reference Guarding Against Electrostatic Damage, publication [8000-4.5.2](#) or any other applicable ESD protection handbook.



ATTENTION: Configuring an analog input for 0...20 mA operation and driving it from a voltage source could cause component damage. Verify proper configuration before applying input signals.



ATTENTION: A contactor or other device that routinely disconnects and reapplies the AC line to the drive to start and stop the motor can cause drive hardware damage. The drive is designed to use control input signals that start and stop the motor. If an input device is used, operation must not exceed 1 cycle per minute or drive damage can occur.



ATTENTION: The “adjust freq” portion of the bus regulator function is useful for preventing nuisance overvoltage faults that result from aggressive decelerations, overhauling loads, and eccentric loads. It forces the output frequency to be greater than commanded frequency while the drive’s bus voltage is increasing towards levels that can cause a fault; however, it can also cause either of the following two conditions to occur.

- Fast positive changes in input voltage (more than a 10% increase within 6 minutes) can cause uncommanded positive speed changes; however an F25 “OverSpeed Limit” fault occurs if the speed reaches P82 [Max Speed] + P83 [Overspeed Limit]. If this condition is unacceptable, take these actions;
 - 1) limit supply voltages within the specification of the drive and,
 - 2) limit fast positive input voltage changes to less than 10%. Without taking such actions, if this operation is unacceptable, the “adjust freq” portion of the bus regulator function must be disabled (see parameters 161 [Bus Reg Mode A] and 162 [Bus Reg Mode B]).
 - Actual deceleration times can be longer than commanded deceleration times; however, a “Decel Inhibit” fault is generated if the drive stops decelerating altogether. If this condition is unacceptable, the “adjust freq” portion of the bus regulator must be disabled (see parameters 161 [Bus Reg Mode A] and 162 [Bus Reg Mode B]). In addition, installing a properly sized dynamic brake resistor provides equal or better performance in most cases.
- Note:** These faults are not instantaneous and have shown test results that take 2...12 seconds to occur.

Output Contactor Precaution



ATTENTION: To guard against drive damage when using output contactors, the following information must be read and understood. One or more output contactors can be installed between the drive and motors for disconnecting or isolating certain motors/loads. If a contactor is opened while the drive is operating, power is removed from the respective motor, but the drive continues to produce voltage at the output terminals. In addition, reconnecting a motor to an active drive (by closing the contactor) could produce excessive current that can cause the drive to fault. If any of these conditions are determined to be undesirable or unsafe, wire an auxiliary contact on the output contactor to a drive digital input that is programmed as "Enable." With the drive Enable input that is wired to the output contactor, the drive can coast-to-stop (cease output) whenever the output contactor is opened.

EMC Instructions

The following section provides instructions for Electromagnetic Compatibility (EMC) compliance.

CE Conformity⁽¹⁾

Conformity with the Low Voltage (LV) and EMC Directive has been demonstrated by using harmonized European Norm (EN) standards that are published in the Official Journal of the European Communities. PowerFlex Drives comply with the EN standards that are listed when installed according to the user manuals and reference manuals.

CE declarations of conformity are available online at:

<http://www.rockwellautomation.com/rockwellautomation/certification/overview.page>

Low Voltage Directive (2014/35/EU)

- EN61800-5-1, electronic equipment for use in power installations.

EMC Directive (2014/30/EU)

- EN61800-3, adjustable speed electrical power drive systems Part 3: EMC product standard including specific test methods.

General Notes

- Some drives are equipped with an adhesive label on the top of the drive. If the adhesive label is removed, the drive must be installed in an enclosure with side openings less than 12.5 mm (0.5 in.) and top openings less than 1.0 mm (0.04 in.) to maintain compliance with the LV directive.
- Use a motor cable that is as short as possible to avoid electromagnetic emission and capacitive currents.
- Do not use line filters in ungrounded systems.
- PowerFlex drives can cause radio interference if used in a residential or domestic environment. Follow national and local industrial safety regulations and/or electrical codes, in addition to the essential requirements for CE compliance (see page 7), to prevent radio interference.
- Conformity of the drive with CE EMC requirements does not mean that an entire machine or installation complies with CE EMC requirements. Many factors can influence total machine/installation compliance.
- PowerFlex drives can generate conducted low-frequency disturbances (harmonic emissions) on the AC supply system. More information regarding harmonic emissions can be found in the PowerFlex 70 EC and 700 VC Reference Manual, publication [PFLEX-RM004](#).

(1) CE certification testing has not been completed for 600V class drives.

Essential Requirements for CE Compliance

These eight conditions **must** be satisfied for PowerFlex drives to meet the requirements of EN61800-3:

- Standard PowerFlex 70 CE compatible drive.
- Review important precautions/attention statements throughout this manual before installing the drive.
- The drive installation cannot include the encoder interface option (20A-ENC-1, drive catalog number, position 16 must be 0. For example: 20Axxxxxxxxxx0).
- Ground the drive as described in General Grounding Requirements on page 19.
- Output power, control (I/O), and signal wiring must be braided, shielded cable with a coverage of 75% or better, metal conduit or equivalent attenuation.
- For B and E frame drives only, ferrite core kit (20A-EMC01) must be installed on the I/O cable, as close to the drive as possible, per [Ferrite Core Installation on B Frame and E Frame Drives Only](#).

Ferrite Core Installation on B Frame and E Frame Drives Only

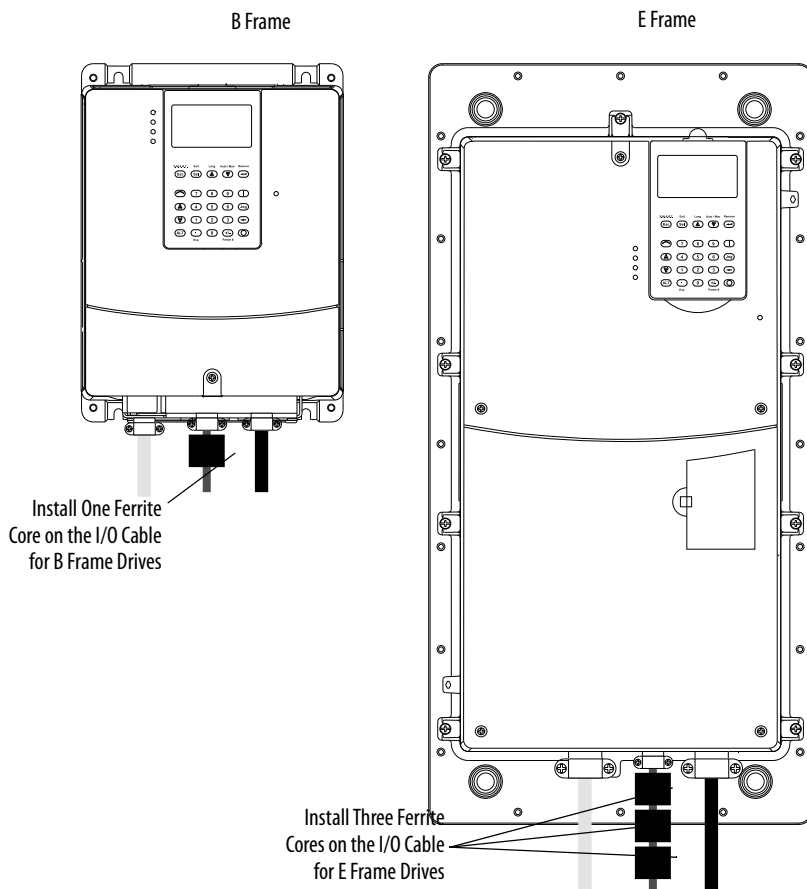

- All shielded cables must terminate with the proper shielded connector
- Comply with the conditions in [PowerFlex 70 EN61800-3 EMC Compatibility](#) on page 8.

PowerFlex 70 EN61800-3 EMC Compatibility

Frame	Drive Description	Second Environment				First Environment Restricted Distribution
		Restrict Motor Cable to 40 m (131 ft)	Internal Filter Option	External Filter	Input Ferrite (1)	
A	Drive only	X		X		See PowerFlex Reference Manual, publication PFLEX-RM001
	With any comm option	X		X		
	With remote I/O	X		X	X	
B	Drive only	X	X			
	With any comm option	X	X			
	With remote I/O	X	X		X	
C, D, E	Drive only	X				
	With any comm option	X				
	With remote I/O	X			X	

(1) Input cables through a Ferrite Core (frames A, B, and C Fair-Rite #2643102002 or equivalent, frames D and E Fair-Rite #2643251002 or equivalent).

Step 2: Mount the Drive – Minimum Requirements

This section describes the minimum requirements to mount the drive.

Minimum Mounting Clearances

Specified vertical clearance requirements are intended to be from the drive to the closest object that can restrict airflow through the drive heat sink and chassis. The drive must be mounted in a vertical orientation as shown, and must make full contact with the mounting surface. Do not use standoffs or spacers. In addition, inlet air temperature must not exceed the product specification.

Maximum Surrounding Air Temperature

Enclosure Rating	Temperature Range
Open Type, IP 20, NEMA/UL Type 1 and flange mount	0...50 °C (32...122 °F)
IP54 and IP66 NEMA/UL Type 4X/12	0...40 °C (32...104 °F)



ATTENTION: Some drives are equipped with an adhesive label on the top of the chassis. Removing the adhesive label from the drive changes the NEMA/UL enclosure rating from Type 1 Enclosed to Open Type.

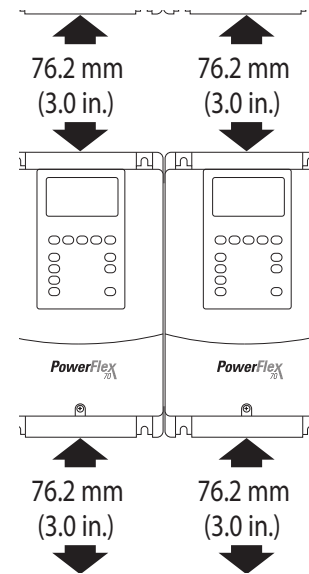

Power Ratings, Dimensions, and Approximate Weights

This section provides power ratings, dimensions, and weights for the drives.

Power Ratings

Output Power		Frame Size								
kW ND (HD)	Hp ND (HD)	208...240V AC Input			400...480V AC Input			600V AC Input		
		Not Filtered ⁽¹⁾	Filtered ⁽²⁾	IP66 NEMA/UL Type 4X/12 ⁽³⁾	Not Filtered ⁽¹⁾	Filtered ⁽²⁾	IP66 NEMA/UL Type 4X/12 ⁽³⁾	Not Filtered ⁽¹⁾	Filtered ⁽²⁾	IP66 NEMA/UL Type 4X/12 ⁽³⁾
0.37 (0.25)	0.5 (0.33)	A	B	B	A	B	B	A	–	B
0.75 (0.55)	1 (0.75)	A	B	B	A	B	B	A	–	B
1.5 (1.1)	2 (1.5)	B	B	B	A	B	B	A	–	B
2.2 (1.5)	3 (2)	B	B	B	B	B	B	B	–	B
4 (3)	5 (3)	–	C	D	B	B	B	B	–	B
5.5 (4)	7.5 (5)	–	D	D	–	C	D	C	–	D
7.5 (5.5)	10 (7.5)	–	D	D	–	C	D	C	–	D
11 (7.5)	15 (10)	–	D	D	–	D	D	D	–	D
15 (11)	20 (15)	–	E	E	–	D	D	D	–	D
18.5 (15)	25 (20)	–	E	E	–	D	D	D	–	D
22 (18.5)	30 (25)	–	–	–	–	D	D	D	–	D
30 (22)	40 (30)	–	–	–	–	E	E	–	E	E
37 (30)	50 (40)	–	–	–	–	E	E	–	E	E

(1) Not filtered is indicated if position 13 of the catalog number = N.

(2) Filtered is indicated if position 13 of the catalog number = A.

(3) For indoor use only.

Dimension Drawings

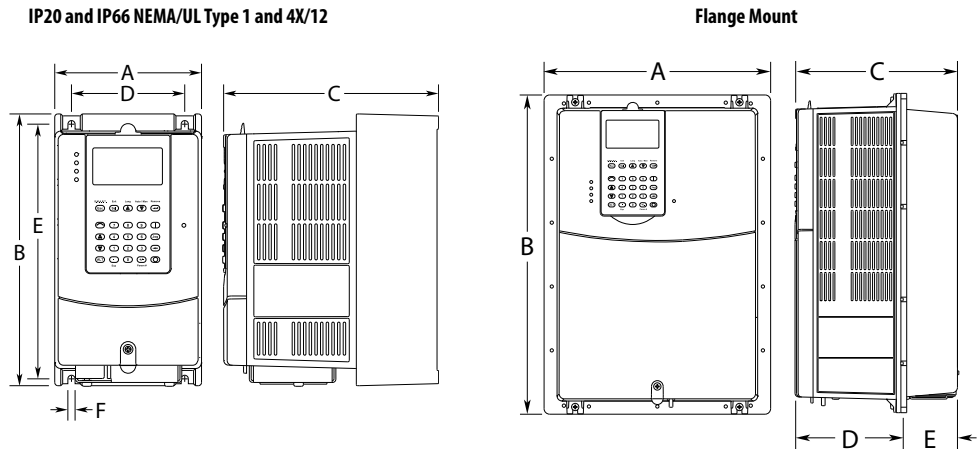

Dimensions and Approximate Weights

Frame	Dimensions, mm (in.)						Weight ⁽³⁾ kg (lb)
	A	B	C	D	E	F	
IP20 NEMA/UL Type 1							
A	122.4 (4.82)	225.7 (8.89)	179.8 (7.08)	94.2 (3.71)	211.6 (8.33)	5.8 (0.23)	2.71 (6.0)
B	171.7 (6.76)	234.6 (9.24)	179.8 (7.08)	122.7 (4.83)	220.2 (8.67)	5.8 (0.23)	3.60 (7.9)
C	185.0 (7.28)	300.0 (11.81)	179.8 (7.08)	137.6 (5.42)	285.6 (11.25)	5.8 (0.23)	6.89 (15.2)
D	219.9 (8.66)	350.0 (13.78)	179.8 (7.08)	169.0 (6.65)	335.6 (13.21)	5.8 (0.23)	9.25 (20.4)
E ⁽¹⁾	280.3 (11.04)	555.8 (21.88)	207.1 (8.15)	200.0 (7.87)	491.0 (19.33)	6.9 (0.27)	18.60 (41.0)
IP66 NEMA/UL Type 4X/12 (for Indoor Use Only)							
B	171.7 (6.76)	239.8 (9.44)	203.3 (8.00)	122.7 (4.83)	220.2 (8.67)	5.8 (0.23)	3.61 (8.0)
D	219.9 (8.66)	350.0 (13.78)	210.7 (8.29)	169.0 (6.65)	335.6 (13.21)	5.8 (0.23)	9.13 (20.1)
E ⁽¹⁾⁽²⁾	280.3 (11.04)	555.8 (21.88)	219.8 (8.65)	200.0 (7.87)	491.0 (19.33)	6.9 (0.27)	18.60 (41.0)
Flange Mount							
A	156.0 (6.14)	225.8 (8.89)	178.6 (7.03)	123.0 (4.84)	55.6 (2.19)	–	2.71 (6.0)
B	205.2 (8.08)	234.6 (9.24)	178.6 (7.03)	123.0 (4.84)	55.6 (2.19)	–	3.60 (7.9)
C	219.0 (8.62)	300.0 (11.81)	178.6 (7.03)	123.0 (4.84)	55.6 (2.19)	–	6.89 (15.2)
D	248.4 (9.78)	350.0 (13.78)	178.6 (7.03)	123.0 (4.84)	55.6 (2.19)	–	9.25 (20.4)
E	280.3 (11.04)	555.8 (21.88)	207.1 (8.15)	117.2 (4.61)	89.9 (3.54)	–	18.60 (41.0)

(1) IP20 and IP66 frame E drives are manufactured with a flange-like heat sink with mounting holes.

(2) Frame E is also available in IP54 NEMA/UL Type 12 as a wall/machine mount.

(3) Approximate weights include the HIM.

PowerFlex 70 IP20 NEMA/UL Type 1 Bottom View Dimensions, mm (in.)

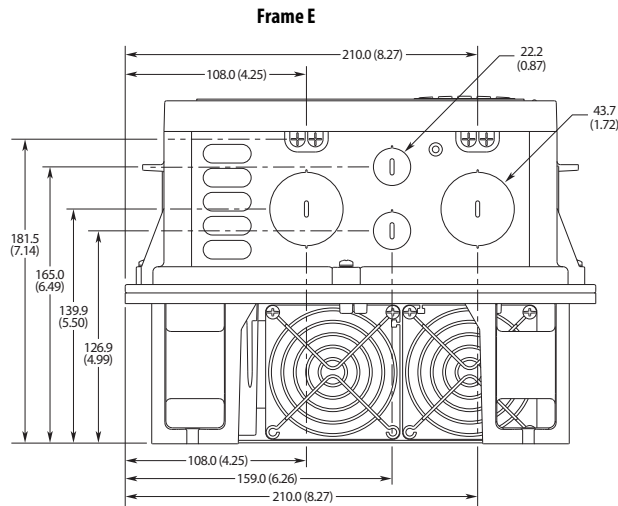
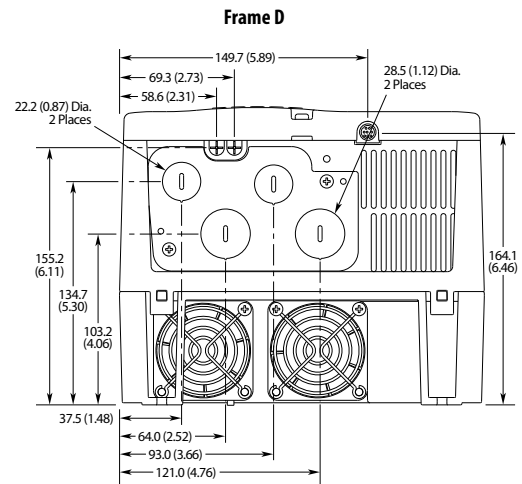
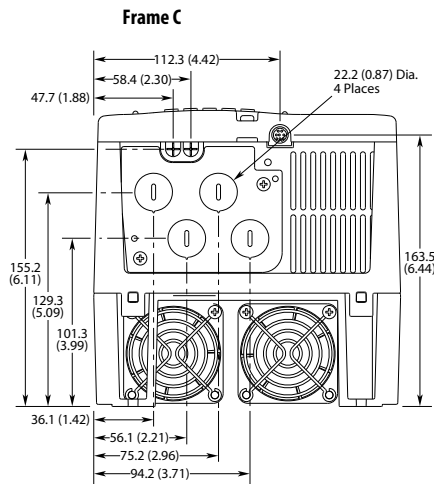
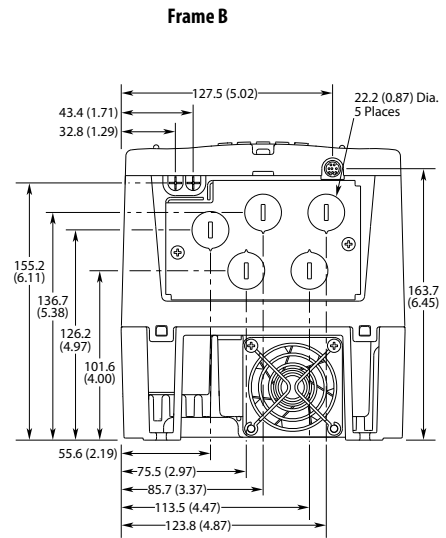
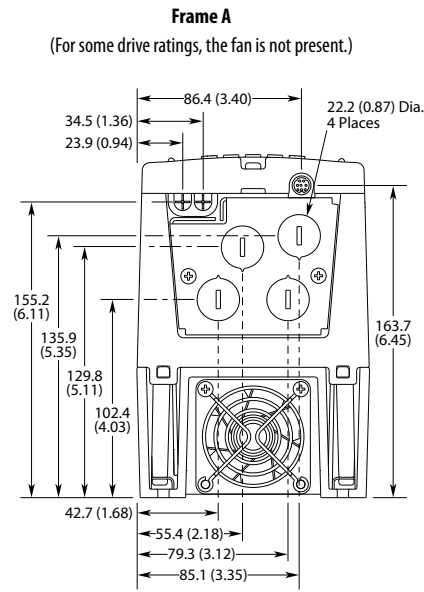

**PowerFlex 70 IP 66 NEMA/UL Type 4X/12 Bottom View Dimensions, mm (in.)
(for indoor use only)**

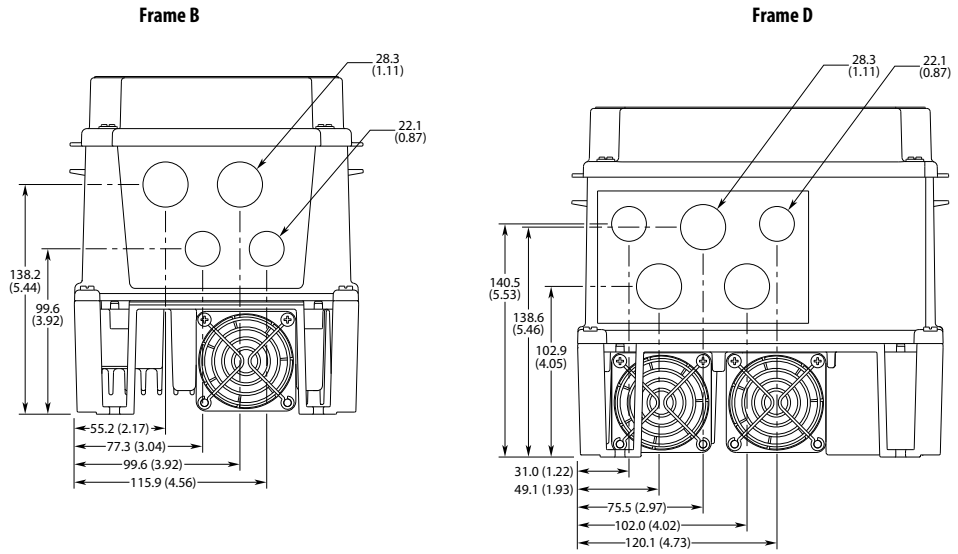

PowerFlex 70 IP 54 / IP 66 NEMA/UL Type 4X/12 Bottom View Dimensions, mm (in.)

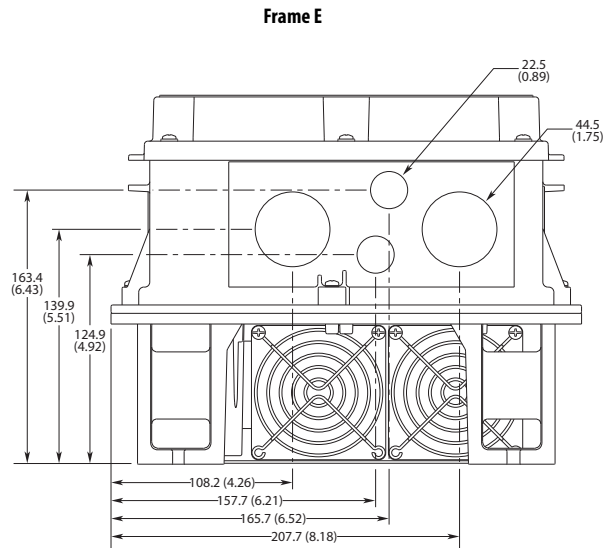

PowerFlex 70 Flange Mount Bottom View Dimensions, mm (in.)

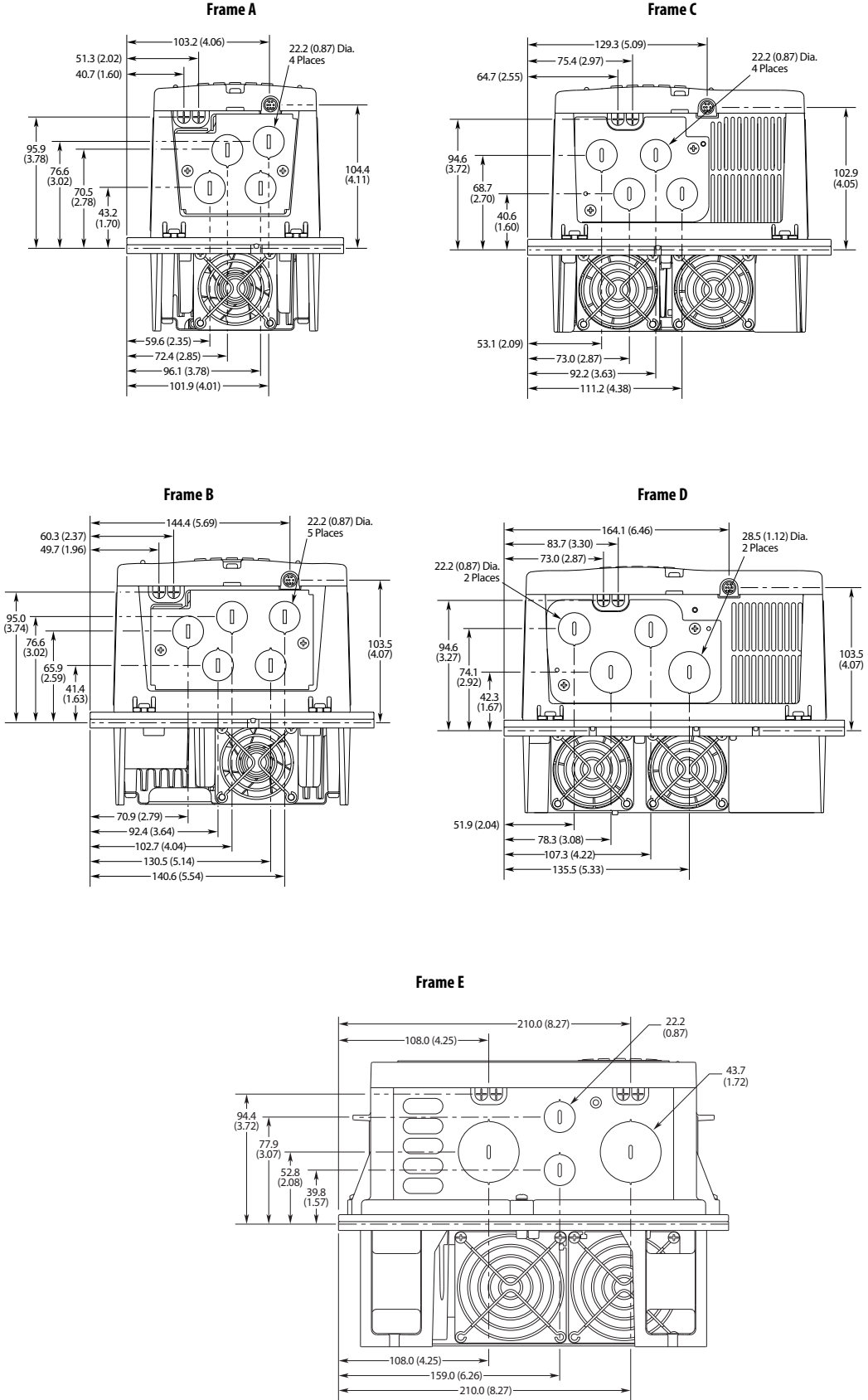

PowerFlex 70 Cutout Dimensions

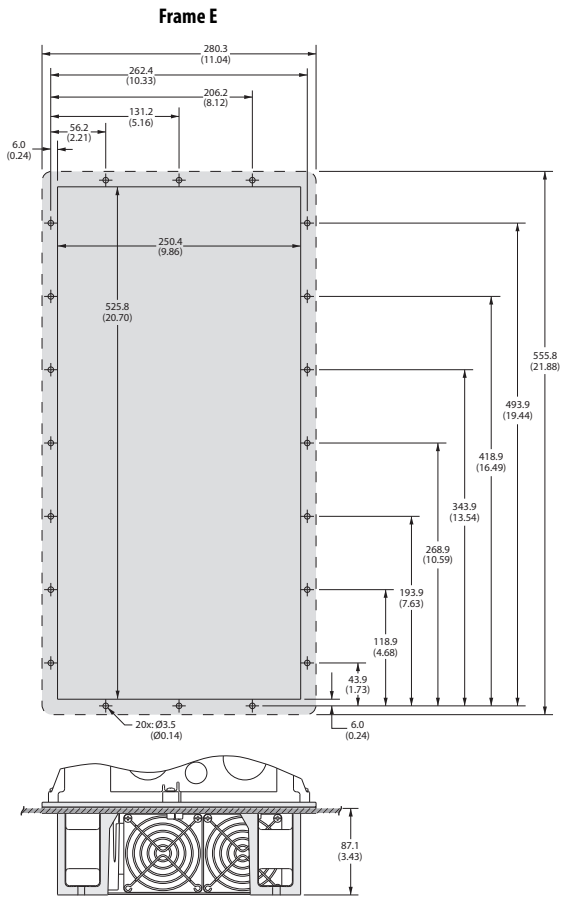
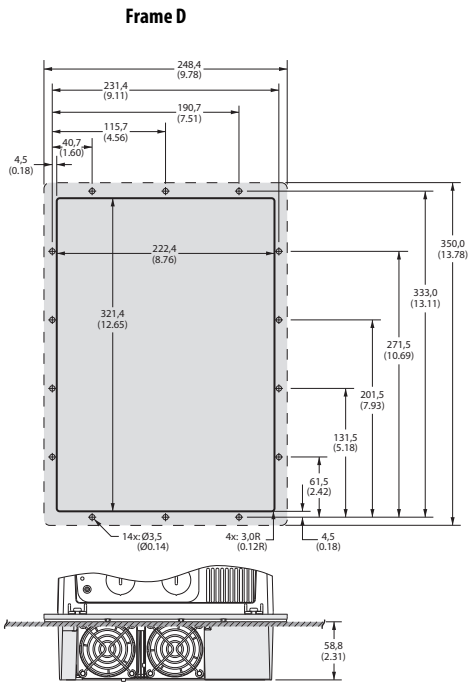
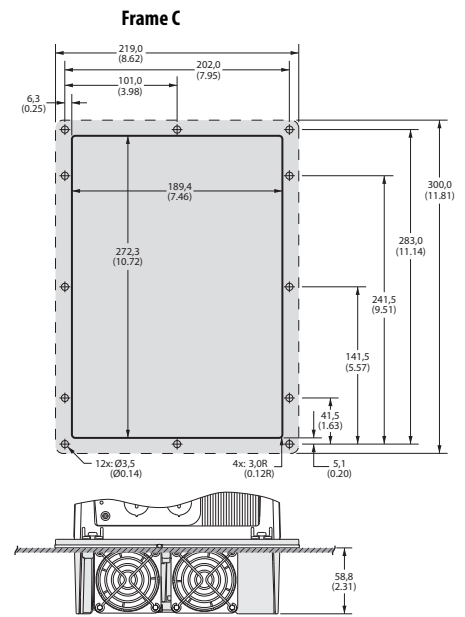
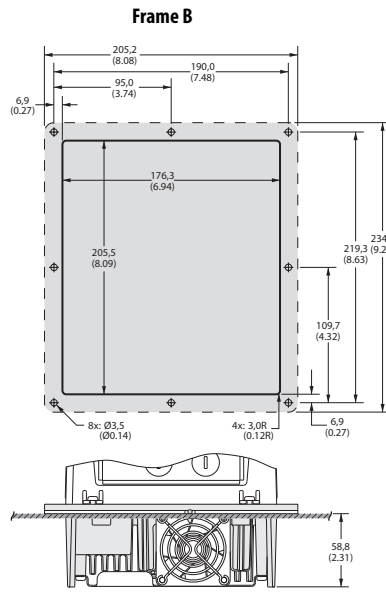
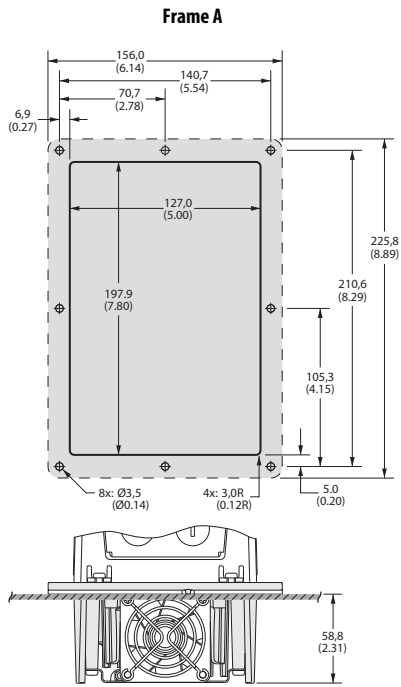

Step 3: Wire the Drive – Wire Recommendations

This section describes wiring recommendations for the drive.

Opening the Cover

To open the cover, follow the steps for your drive enclosure that is shown.

IP20 NEMA/UL Type 1

1. Loosen the cover screw.

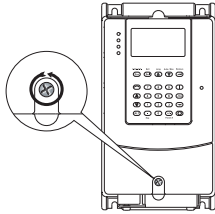

2. Pull the cover straight off the chassis to avoid damaging the connector pins.

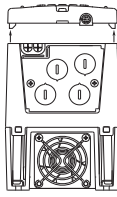

IP66 NEMA/UL Type 4X/12 (for Indoor Use Only)

1. Loosen the cover screws.

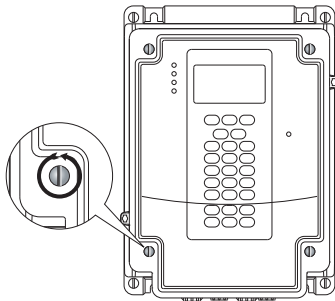

2. Pull the cover straight off the chassis.

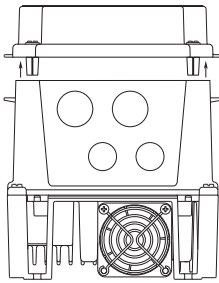

IMPORTANT Torque cover screws to 0.79 N•m (7 lb•in).

IP66 NEMA/UL Type 4X/12 Indoor Installations

Use the plugs that are supplied with IP66 NEMA/UL Type 4X/12 rated drives to seal unused holes in the conduit entry plate.

For the best seal, be sure that the inner rim of the plug is fully seated against the edge of the conduit entry hole.

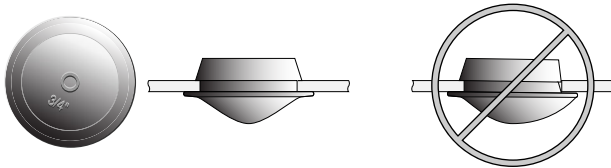

Wiring Specifications

Type	Wire Types	Description	Min Insulation Rating
Power (1)(2)	Standard 600V, 90 °C (194 °F) XHHW2/RHW-2 Anixter B209500-B209507, Belden 29501-29507 (or equivalent)	Four tinned copper conductors with XLPE insulation. Copper braid/aluminum foil combination shield and tinned copper drain wire. PVC jacket.	–
Signal (1)(3)(4)	Standard analog I/O Belden 8760/9460 (or equivalent)	0.750 mm ² (18 AWG), twisted-pair, 100% shield with drain .	300V, 75...90 °C (167...194 °F)
	Belden 8770 (or equivalent)	0.750 mm ² (18 AWG), three-conductor, shielded for remote pot.	
Digital I/O (1)(3)(4)	Shielded Multi-conductor shielded cable such as Belden 8770 (or equivalent)	0.750 mm ² (18 AWG), three-conductor, shielded.	300V, 60 °C (140 °F)

(1) Control and signal wires must be separated from power wires by at least 0.3 m (1 ft).

(2) We recommend the use of shielded wire for AC input power (even if it is not necessary).

(3) If the wires are short and contained within a cabinet that has no sensitive circuits, we recommend the use of shielded wire (even if it is not necessary).

(4) I/O terminals that are labeled “(–)” or “Common” are not referenced to earth ground and are designed to greatly reduce common mode interference. Grounding these terminals can cause signal noise.

AC Supply Source Considerations

PowerFlex 70 drives are suitable for use on a circuit capable of delivering up to a maximum of 200,000 rms symmetrical amperes, and a maximum of 600V.



ATTENTION: To guard against personal injury and/or equipment damage that is caused by improper fusing or circuit breaker selection, use the recommended line fuses/circuit breakers that are specified in Drive, Fuse, and Circuit Breaker Ratings on page 22.

If the drive has a system ground fault monitor (residual current-operated protective device), use Type B (adjustable) devices to avoid nuisance tripping.

Unbalanced, Ungrounded, High Resistance or B-phase Grounded Distribution Systems

Install an isolation transformer on an ungrounded distribution system where the line-to-ground voltages on any phase could exceed 125% of the nominal line-to-line voltage. See Wiring and Grounding Guidelines for PWM AC Drives, publication [DRIVES-IN001](#), for more information on impedance grounded and ungrounded systems.

Input Power Conditioning

Some events on the power system supplying a drive can cause component damage or shortened product life. These events are divided into two basic categories that are described:

- **All Drives**
 - The power system has power factor correction capacitors that are switched in and out of the system, either by the user or by the power company.
 - The power source has intermittent voltage spikes in excess of 6000V. These spikes could be caused by other equipment on the line, or by events such as lightning strikes.
 - The power source has frequent interruptions.
- **5 Hp or Less Drives** (in addition to all drives above)
 - The nearest supply transformer is larger than 100 kVA, or the available short circuit (fault) current is greater than 100,000 A.
 - The impedance in front of the drive is less than 0.5%.

If any or all of these conditions exist, we recommend that you install a minimum amount of impedance between the drive and the source. This impedance could come from the supply transformer itself, the cable between the transformer and drive, or an additional transformer or reactor. To calculate the impedance, use the information that is supplied in the Wiring and Grounding Guidelines for Pulse Width Modulated (PWM) AC Drives, publication [DRIVES-IN001](#).

Single-phase Input Power

The PowerFlex 70 drive is typically used with a three-phase input supply. Underwriters Laboratories (UL) lists the drive to operate on single-phase input power. Single-phase operation provides 50% of the three-phase rated current. See [208/240V AC Single-phase Input Drive Ratings and Input Protection Devices](#) on page 24 through [600V AC Single-phase Input Drive Ratings and Input Protection Devices](#) on page 26.

Generator Input Power

Contact technical support for details on how to power a drive properly when using generator power. See Rockwell Automation Support on the back cover.

Power Terminal Block

Typical Power Terminal Block Location (B frame shown)

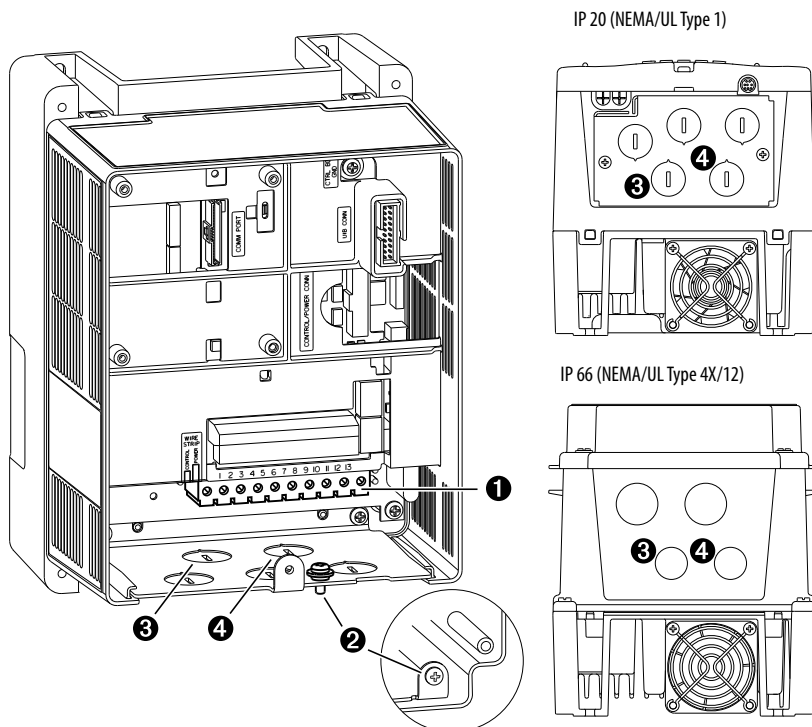

Power Terminal Block Specifications

No.	Name	Frame	Description	Wire Size Range ⁽¹⁾		Torque	
				Max mm ² (AWG)	Min mm ² (AWG)	Max N·m (lb·in)	Recommended N·m (lb·in)
❶	Power terminal block	A, B, C	Input power and motor connections	4.0 (10)	0.3 (22)	1.1 (10)	0.8 (7)
		D	Input power and motor connections	10.0 (6)	0.8 (18)	1.7 (15)	1.4 (12)
		E	Input power and motor connections	25.0 (3)	2.5 (14)	2.71 (24)	2.71 (24)
❷	SHLD terminal	All	Terminating point for wiring shields	—	—	1.6 (14)	1.6 (14)

(1) Maximum/minimum sizes that the terminal block can accept – these are not recommendations.

Wire Routing Recommendations

No.	Description
❸	Suggested entry for incoming line wiring.
❹	Suggested entry for motor wiring.

Cable Entry Plate Removal

If more wiring access is needed, the cable entry plate on all drive frames can be removed. Loosen the screws that secure the plate to the heat sink and slide out the plate.

Frame A, B, C, D Power Terminal Block, and DC Bus Test Points

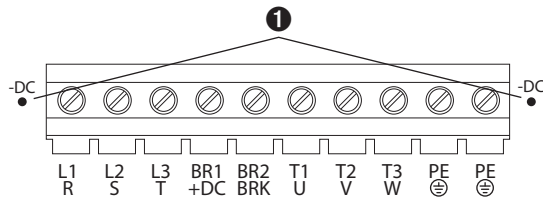

Frame E Power Terminal Block

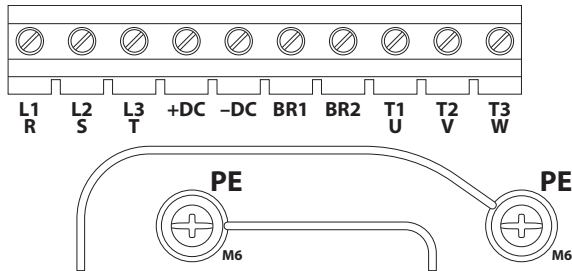

Terminal	Description	Notes
R	R (L1)	Three-phase AC line input power. For single-phase input, connect to any two terminals.
S	S (L2)	
T	T (L3)	
BR1	DC brake	DB resistor connection - Important: Do not connect both an internal and external DB resistor simultaneously. Doing this can violate the minimum allowed DB resistance and cause damage to the drive.
BR2	DC brake	
U	U (T1)	To the motor
V	V (T2)	To the motor
W	W (T3)	To the motor
PE	PE ground	-
PE	PE ground	-
-DC	DC bus (-)	① Test point on Frames A, B, C, and D are to the left or right of the power terminal block. Frame E has a dedicated terminal.
+DC	DC bus (+)	-

Power Input Terminals on Frame B with Internal RFI Filter Option

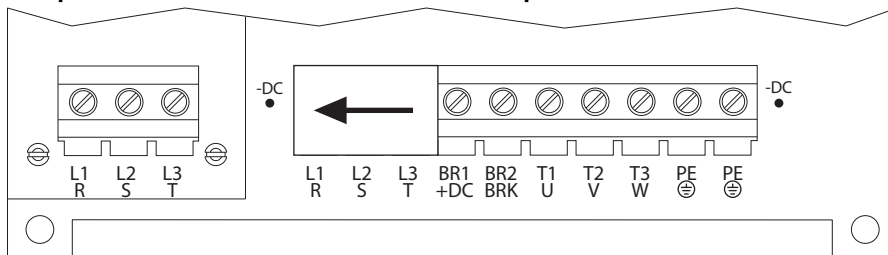

General Grounding Requirements

IMPORTANT The safety ground for the drive (PE) must be connected to system ground.

Ground impedance must conform to the requirements of national and local industrial safety regulations and/or electrical codes. Check the integrity of all ground connections periodically.

For installations within a cabinet, one safety ground point or ground bus bar connected directly to building steel (girder, joist) can be used. All circuits including the AC input ground conductor can be grounded independently and directly to this point/bar.

Typical Grounding

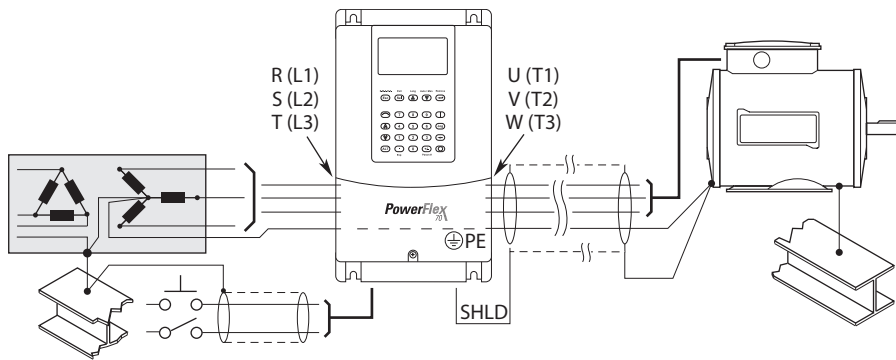

Safety Ground (PE)

The safety ground for the drive is required by code. This point must be connected to adjacent building steel (girder, joist), a floor ground rod, or bus bar (see [Typical Grounding](#)). Grounding points must comply with national and local industrial safety regulations and/or electrical codes.

Shield Termination - SHLD

The shield terminal (see [Typical Power Terminal Block Location \(B frame shown\)](#) on page 17) provides a grounding point for the motor cable shield. The motor cable shield can be connected to this terminal on the drive (on the drive end) and the motor frame (on the motor end). A shield terminating cable gland can also be used.

If you use shielded cable for control and signal wiring, the shield can be grounded at the source end, and not the drive end.

RFI Filter Grounding

IMPORTANT Use RFI filters only in installations with grounded AC supply systems that are permanently installed and solidly grounded (bonded) to the building power distribution ground.

If you use an optional radio frequency interference (RFI) filter, relatively high ground leakage currents can be present. Be sure that the incoming supply neutral is solidly connected (bonded) to the same building power distribution ground. Grounding must not rely on flexible cables and must exclude any form of plug or socket that permits inadvertent disconnection. Some local codes require redundant ground connections. Periodically check the integrity of all connections. See the instructions that are supplied with the filter.



ATTENTION: The PowerFlex 70 does not provide branch short circuit protection. See Drive, Fuse, and Circuit Breaker Ratings on page 22 for the recommended fuse or circuit breaker to protect against short circuits.

Power Wiring



ATTENTION: National Codes and standards (NEC, VDE, BSI, and others) and local codes outline provisions for safely installing electrical equipment. Installation must comply with specifications regarding wire types, conductor sizes, branch circuit protection, and disconnect devices. Failure to do so can result in personal injury and/or equipment damage.

Cable Types Acceptable for 200...600V Installations

Various cable types are acceptable for drive installations. For many installations, unshielded cable is adequate as long as the cable is separated from sensitive circuits. As an approximate guide, provide a spacing of 0.3 m (1 ft) for every 10 m (32.8 ft) of length. In all cases, do not use long parallel runs. Do not use cable with an insulation thickness fewer than 15 mils (0.4 mm/0.015 in.). Use copper wire. Wire gauge requirements and recommendations are based on 75 °C (167 °F). Do not reduce wire gauge when using higher temperature wire.

Unshielded

Thermoplastic High Heat-resistant Nylon-coated (THHN), Thermoplastic Heat and Water-resistant Nylon-coated (THWN), or similar wire is acceptable for drive installation in dry environments as long as adequate free air space and/or conduit fill rate limits are provided. The wire must have a minimum insulation thickness of 15 mils (0.4 mm/0.015 in.) and cannot have large variations in insulation concentricity.

IMPORTANT Do not use THHN or similarly coated wire in wet areas.

Shielded/Armored Cable

Shielded cable contains the general benefits of multi-conductor cable with the added benefit of a copper braided shield that can contain much of the noise that is generated by a typical AC Drive. Use shielded cable for installations with sensitive equipment such as weigh scales, capacitive proximity switches, and other devices that can be affected by electrical noise in the distribution system. Applications with large numbers of drives in a similar location, imposed EMC regulations, or a high degree of communications/networking are also good candidates for shielded cable.

Shielded cable can also help reduce shaft voltage and induced bearing currents for some applications. In addition, the increased impedance of shielded cable can help extend the distance that the motor can be from the drive without the addition of motor protective devices, such as terminator networks. See Reflected Wave in Wiring and Grounding Guidelines for PWM AC Drives, publication [DRIVES-IN001](#).

Consider the general specifications of the environment of the installation, including temperature, flexibility, moisture characteristics, and chemical resistance. In addition, a braided shield can be included and be specified by the cable manufacturer as having coverage of at least 75%. An additional foil shield can greatly improve noise containment.

A good example of recommended cable is Belden 295xx (xx determines gauge). This cable has four Cross-linked Polyethylene (XLPE) insulated conductors with a 100% coverage foil and an 85% coverage copper braided shield (with drain wire) surrounded by a Polyvinyl Chloride (PVC) jacket.

Other types of shielded cable are available, but the use of these types can limit the allowable cable length. For example, some of the newer cables bundle four conductors of THHN wire and wrap them tightly with a foil shield. This type of construction can greatly increase the cable charging current that is required and reduce the overall drive performance. Unless specified in the individual distance tables as tested with the drive, these cables are not recommended and their performance against the lead length limits is not known.

Recommended Shielded Wire

Location	Rating/Type	Description
Standard (option 2)	Tray rated 600V, 90 °C (194 °F) RHH/RHW-2 Anixter OLF-7xxxx or equivalent	Three tinned copper conductors with XLPE insulation. 5 mil single helical copper tape (25% overlap minimum) with three bare copper grounds in contact with the shield. PVC jacket.
Class I and II; Division I and II	Tray rated 600V, 90 °C (194 °F) RHH/RHW-2 Anixter 7V-7xxxx-3G or equivalent	Three bare copper conductors with XLPE insulation and impervious corrugated continuously welded aluminum armor. Black sunlight resistant PVC jacket overall. Three copper grounds on #10 AWG and smaller.



ATTENTION: To avoid a possible shock hazard that is caused by induced voltages, unused wires in the conduit must be grounded at both ends. Also, if a drive sharing a conduit is being serviced or installed, disable all drives that are using that conduit. Disabling all drives helps minimize the possible shock hazard from cross coupled motor leads.

Motor Cable Lengths

Typically, motor lead lengths less than 30 m (approximately 100 ft) are acceptable. However, if your application requires longer lengths, refer to Wiring and Grounding Guidelines for Pulse Width Modulated (PWM) AC Drives, publication [DRIVES-IN001](#), for details.

Electronic Motor Overload Protection

Class 10 motor overload protection according to NEC article 430 and motor over-temperature protection according to NEC article 430.126 (A)(2). UL 508C File E59272.

Drive, Fuse, and Circuit Breaker Ratings

Integral solid-state short circuit protection does not provide branch circuit protection. Branch circuit protection must be provided in accordance with the National Electric Code (NEC) and any additional local codes, or the equivalent. The tables on the following pages provide drive ratings (including continuous, 1 minute and 3 seconds) and recommended AC line input fuse and circuit breaker information. Both types of short circuit protection are acceptable for UL and IEC requirements. Sizes that are listed are the recommended sizes that are based on 40 °C (104 °F) and the U.S. N.E.C. Other country, state, or local codes may require different ratings.

Fusing

The recommend fuse types are listed. If available current ratings do not match those listed in the tables that are provided, choose the next higher fuse rating.

- IEC – BS88 (British Standard) Parts 1 & 2, EN60269-1, Parts 1 & 2⁽¹⁾, type gG or equivalent should be used.
- UL – UL Class CC, T, RK1, or J should be used.

Circuit Breakers

The “non-fuse” listings in the following tables include inverse time circuit breakers, instantaneous trip circuit breakers (motor circuit protectors), and 140M/MT Motor Protection Circuit Breakers that are used as self-protected combination motor controllers. If one of these devices is chosen as the desired protection method, the following requirements apply:

- IEC – Both types of circuit breakers and 140M/MT self-protected combination motor controllers are acceptable for IEC installations.
- UL – Only inverse time circuit breakers and the specified 140M/MT self-protected combination motor controllers are acceptable for UL installations.

208/240V AC Three-phase Input Drive Ratings and Input Protection Devices

Cat.No.	Frame (1)	Hp Rating		Input Ratings		Output Current Rating [A]			Dual Element Time Delay Fuse [A]		Non-time Delay Fuse [A]		Circuit Breaker [A] ⁽⁴⁾	Motor Circuit Protector [A] ⁽⁶⁾	140M/MT Motor Protection Circuit Breaker ^{(7) (8)}			
		ND	HD	A	kVA	Cont.	60 s	3 s	Min ⁽²⁾	Max ⁽³⁾	Min ⁽²⁾	Max ⁽³⁾			Max ⁽⁵⁾	Max ⁽⁵⁾	Available Catalog Numbers ⁽⁹⁾	Min Enclosure Volume (in. ³) ⁽¹⁰⁾
208V AC Input																		
20AB2P2	A	0.5	0.33	2.9	1.1	2.5	2.7	3.7	6	6	6	10	15	7	140M-C2E-B40 140MT-C3E-B40	140M-D8E-B40 140MT-D9E-B40	—	3441
20AB4P2	A	1	0.75	5.6	2	4.8	5.5	7.4	10	10	10	17.5	15	7	140M-C2E-B63 140MT-C3E-B63	140M-D8E-B63 140MT-D9E-B63	—	3441
20AB6P8	B	2	1.5	10	3.6	7.8	10.3	13.8	15	15	15	30	30	15	140M-C2E-C10 140MT-C3E-C10	140M-D8E-C10 140MT-D9E-C10	140M-F8E-C10	3441
20AB9P6	B	3	2	14	5.1	11	12.1	16.5	20	25	20	40	40	30	140M-C2E-C16 140MT-C3E-C16	140M-D8E-C16 140MT-D9E-C16	140M-F8E-C16	3441
20AB015	C	5	3	16	5.8	17.5	19.2	26.6	20	35	20	70	70	30	140M-C2E-C20 140MT-C3E-C20	140M-D8E-C20 140MT-D9E-C20	140M-F8E-C20	3441
20AB022	D	7.5	5	23.3	8.3	25.3	27.8	37.9	30	50	30	100	100	30	—	140M-D8E-C25 140MT-D9E-C25	140M-F8E-C25	5098
20AB028	D	10	7.5	29.8	10.7	32.2	37.9	50.6	40	70	40	125	125	50	—	—	140M-F8E-C32	5098
20AB042	D	15	10	39.8	14.3	43	55.5	74	60	100	60	175	175	70	—	—	140M-F8E-C45	5098
20AB054	E	20	15	57.5	20.7	62.1	72.4	96.6	80	125	80	200	200	100	—	—	—	—
20AB070	E	25	20	72.3	26.0	78.2	93.1	124	90	175	90	300	300	100	—	—	—	—
240V AC Input																		
20AB2P2	A	0.5	0.33	2.5	1.1	2.2	2.4	3.3	3	4.5	3	8	15	3	140M-C2E-B25 140MT-C3E-B25	140M-D8E-B25 140MT-D9E-B25	—	3441
20AB4P2	A	1	0.75	4.8	2	4.2	4.8	6.4	6	9	6	15	15	7	140M-C2E-B63 140MT-C3E-B63	140M-D8E-B63 140MT-D9E-B63	—	3441
20AB6P8	B	2	1.5	8.7	3.6	6.8	9	12	15	15	15	25	25	15	140M-C2E-C10 140MT-C3E-C10	140M-D8E-C10 140MT-D9E-C10	140M-F8E-C10	3441
20AB9P6	B	3	2	12.2	5.1	9.6	10.6	14.4	20	20	20	35	35	15	140M-C2E-C16 140MT-C3E-C16	140M-D8E-C16 140MT-D9E-C16	140M-F8E-C16	3441
20AB015	C	5	3	13.9	5.8	15.3	17.4	23.2	20	30	20	60	60	30	140M-C2E-C16 140MT-C3E-C16	140M-D8E-C16 140MT-D9E-C16	140M-F8E-C16	3441
20AB022	D	7.5	5	19.9	8.3	22	24.4	33	25	45	25	80	80	30	—	140M-D8E-C25 140MT-D9E-C25	140M-F8E-C25	5098
20AB028	D	10	7.5	25.7	10.7	28	33	44	35	60	35	110	110	50	—	—	140M-F8E-C32	5098
20AB042	D	15	10	38.7	16.1	42	46.2	63	50	90	50	150	150	50	—	—	140M-F8E-C45	5098
20AB054	E	20	15	49.8	20.7	54	63	84	60	100	60	200	200	100	—	—	—	—
20AB070	E	25	20	64.5	26.8	70	81	108	90	150	90	275	275	100	—	—	—	—

See page 26 for notes.

(1) Typical designations include, but may not be limited to the following; Parts 1 & 2: AC, AD, BC, BD, CD, DD, ED, EFS, EF, FF, FG, GF, GG, GH.

400/480V AC Three-phase Input Drive Ratings and Input Protection Devices

Cat.No.	Frame (1)	Hp Rating		Input Ratings		Output Current Rating [A]			Dual Element Time Delay Fuse [A]		Non-time Delay Fuse [A]		Circuit Breaker [A] (4)	Motor Circuit Protector [A] (5)	140M/MT Motor Protection Circuit Breaker (7) (8)			
		ND	HD	A	kVA	Cont.	60 s	3 s	Min (2)	Max (3)	Min (2)	Max (3)			Max (5)	Max (5)	Available Catalog Numbers (9)	
400V AC Input																		
20AC1P3	A	0.37	0.25	1.6	1.1	1.3	1.4	1.9	3	3	3	5	15	3	140M-C2E-B16 140MT-C3E-B16	—	—	3441
20AC2P1	A	0.75	0.55	2.5	1.8	2.1	2.4	3.2	4	6	4	8	15	7	140M-C2E-B25 140MT-C3E-B25	140M-D8E-B25 140MT-D9E-B25	—	3441
20AC3P5	A	1.5	1.1	4.3	3	3.5	4.5	6	6	6	6	12	15	7	140M-C2E-B63 140MT-C3E-B63	140M-D8E-B63 140MT-D9E-B63	—	3441
20AC5P0	B	2.2	1.5	6.5	4.5	5	5.5	7.5	10	10	10	20	20	15	140M-C2E-C10 140MT-C3E-C10	140M-D8E-C10 140MT-D9E-C10	140M-F8E-C10	3441
20AC8P7	B	4	3	11.3	7.8	8.7	9.9	13.2	15	17.5	15	30	30	15	140M-C2E-C16 140MT-C3E-C16	140M-D8E-C16 140MT-D9E-C16	140M-F8E-C16	3441
20AC011	C	5.5	4	10.5	7.6	11.5	13	17.4	15	25	15	45	40	15	140M-C2E-C16 140MT-C3E-C16	140M-D8E-C16 140MT-D9E-C16	140M-F8E-C16	3441
20AC015	C	7.5	5.5	15.1	10.4	15.4	17.2	23.1	20	30	20	60	60	20	140M-C2E-C16 140MT-C3E-C16	140M-D8E-C16 140MT-D9E-C16	140M-F8E-C16	3441
20AC022	D	11	7.5	21.9	15.2	22	24.2	33	30	45	30	80	80	30	—	140M-D8E-C25 140MT-D9E-C25	140M-F8E-C25	5098
20AC030	D	15	11	30.3	21	30	33	45	40	60	40	120	120	50	—	—	140M-F8E-C32	5098
20AC037	D	18.5	15	35	24.3	37	45	60	50	80	50	125	140	50	—	—	140M-F8E-C45	5098
20AC043	D	22	18.5	40.7	28.2	43	56	74	60	90	60	150	160	70	—	—	—	—
20AC060	E	30	22	56.8	39.3	60	66	90	80	125	80	225	240	80	—	—	—	—
20AC072	E	37	30	68.9	47.8	72	90	120	90	150	90	250	280	100	—	—	—	—
480V AC Input																		
20AD1P1	A	0.5	0.33	1.3	1.1	1.1	1.2	1.6	3	3	3	4	15	3	140M-C2E-B16 140MT-C3E-B16	—	—	3441
20AD2P1	A	1	0.75	2.4	2	2.1	2.4	3.2	3	6	3	8	15	3	140M-C2E-B25 140MT-C3E-B25	140M-D8E-B25 140MT-D9E-B25	—	3441
20AD3P4	A	2	1.5	3.8	3.2	3.4	4.5	6	6	6	6	12	15	7	140M-C2E-B40 140MT-C3E-B40	140M-D8E-B40 140MT-D9E-B40	—	3441
20AD5P0	B	3	2	5.6	4.7	5	5.5	7.5	10	10	10	20	20	15	140M-C2E-B63 140MT-C3E-B63	140M-D8E-B63 140MT-D9E-B63	—	3441
20AD8P0	B	5	3	9.8	8.4	8	8.8	12	15	15	15	30	30	15	140M-C2E-C10 140MT-C3E-C10	140M-D8E-C10 140MT-D9E-C10	140M-F8E-C10	3441
20AD011	C	7.5	5	9.4	7.9	11	12.1	16.5	15	20	15	40	40	15	140M-C2E-C16 140MT-C3E-C16	140M-D8E-C16 140MT-D9E-C16	140M-F8E-C16	3441
20AD014	C	10	7.5	12.4	10.4	14	16.5	22	20	30	20	50	50	20	140M-C2E-C16 140MT-C3E-C16	140M-D8E-C16 140MT-D9E-C16	140M-F8E-C16	3441
20AD022	D	15	10	19.9	16.6	22	24.2	33	25	45	25	80	80	30	—	140M-D8E-C25 140MT-D9E-C25	140M-F8E-C25	5098
20AD027	D	20	15	24.8	20.6	27	33	44	35	60	35	100	100	50	—	—	140M-F8E-C32	5098
20AD034	D	25	20	31.2	25.9	34	40.5	54	40	70	40	125	125	50	—	—	140M-F8E-C45	5098
20AD040	D	30	25	36.7	30.5	40	51	68	50	90	50	150	150	50	—	—	140M-F8E-C45	5098
20AD052	E	40	30	47.7	39.7	52	60	80	60	110	60	200	200	70	—	—	—	—
20AD065	E	50	40	59.6	49.6	65	78	104	80	125	80	250	250	100	—	—	—	—

See page 26 for notes.

600V AC Three-phase Input Drive Ratings and Input Protection Devices

Cat.No.	Frame (1)	Hp Rating		Input Ratings		Output Current Rating [A]			Dual Element Time Delay Fuse [A]		Non-time Delay Fuse [A]		Circuit Breaker [A] (4)	Motor Circuit Protector [A] (5)	140M/MT Motor Protection Circuit Breaker (7) (8)			
		ND	HD	A	kVA	Cont.	60 s	3 s	Min (2)	Max (3)	Min (2)	Max (3)			Max (5)	Max (5)	Available Catalog Numbers (9)	
600V AC Input																		
20AE0P9	A	0.5	0.33	1.3	1.3	0.9	1.1	1.4	3	3	3	3.5	15	3	140M-C2E-B16 140MT-C3E-B16	—	—	3441
20AE1P7	A	1	0.75	1.9	2	1.7	2	2.6	3	6	3	6	15	3	140M-C2E-B25 140MT-C3E-B25	140M-D8E-B25 140MT-D9E-B25	—	3441
20AE2P7	A	2	1.5	3	3.1	2.7	3.6	4.8	4	6	4	10	15	7	140M-C2E-B40 140MT-C3E-B40	140M-D8E-B40 140MT-D9E-B40	—	3441
20AE3P9	B	3	2	4.4	4.5	3.9	4.3	5.9	6	8	6	15	15	7	—	140M-D8E-B63 140MT-D9E-B63	—	3441
20AE6P1	B	5	3	7.5	7.8	6.1	6.7	9.2	10	12	10	20	20	15	—	140M-D8E-C10 140MT-D9E-C10	140M-F8E-C10	3441
20AE9P0	C	7.5	5	7.7	8	9	9.9	13.5	10	20	10	35	35	15	—	140M-D8E-C10 140MT-D9E-C10	140M-F8E-C10	3441
20AE011	C	10	7.5	9.8	10.1	11	13.5	18	15	20	15	40	40	15	—	140M-D8E-C16 140MT-D9E-C16	140M-F8E-C16	3441
20AE017	D	15	10	15.3	15.9	17	18.7	25.5	20	35	20	60	60	30	—	—	140M-F8E-C20	5098

600V AC Three-phase Input Drive Ratings and Input Protection Devices

Cat. No.	Frame (1)	Hp Rating		Input Ratings		Output Current Rating [A]			Dual Element Time Delay Fuse [A]		Non-time Delay Fuse [A]		Circuit Breaker [A] (4)	Motor Circuit Protector [A] (6)	140M/MT Motor Protection Circuit Breaker (7) (8)			
		ND	HD	A	kVA	Cont.	60 s	3 s	Min (2)	Max (3)	Min (2)	Max (3)	Max (5)	Max (5)	Available Catalog Numbers (9)			Min Enclosure Volume (in. 3) (10)
20AE022	D	20	15	20	20.8	22	25.5	34	25	45	25	80	80	30	—	—	140M-F8E-C25	5098
20AE027	D	25	20	24.8	25.7	27	33	44	35	60	35	100	100	50	—	—	140M-F8E-C25	5098
20AE032	D	30	25	29.4	30.5	32	40.5	54	40	70	40	125	125	50	—	—	140M-F8E-C32	5098
20AE041	E	40	30	37.6	39.1	41	48	64	50	90	50	150	150	100	—	—	—	—
20AE052	E	50	40	47.7	49.6	52	61.5	82	60	110	60	200	200	100	—	—	—	—

See page 26 for notes.

208/240V AC Single-phase Input Drive Ratings and Input Protection Devices

Cat. No.	Frame (1)	Hp Rating		Input Ratings		Output Current Rating [A]			Dual Element Time Delay Fuse [A]		Non-time Delay Fuse [A]		Circuit Breaker [A] (4)	Motor Circuit Protector [A] (6)	140M/MT Motor Protection Circuit Breaker (7) (8)			
		ND	HD	A	kVA	Cont.	60 s	3 s	Min (2)	Max (3)	Min (2)	Max (3)	Max (5)	Max (5)	Available Catalog Numbers (9)			Min Enclosure Volume (in. 3) (10)

208V AC Input

20AB2P2	A	0.5	0.33	2.9	0.6	1.3	1.6	1.9	6	6	6	10	15	7	140M-C2E-B40 140MT-C3E-B40	140M-D8E-B40 140MT-D9E-B40	—	3441
20AB4P2	A	1	0.75	5.6	1	2.4	2.8	3.7	10	10	10	17.5	15	7	140M-C2E-B63 140MT-C3E-B63	140M-D8E-B63 140MT-D9E-B63	—	3441
20AB6P8	B	2	1.5	10	1.8	3.9	5.2	6.9	15	15	15	30	30	15	140M-C2E-C10 140MT-C3E-C10	140M-D8E-C10 140MT-D9E-C10	140M-F8E-C10	3441
20AB9P6	B	3	2	14	2.6	5.5	6.1	8.3	20	25	20	40	40	30	140M-C2E-C16 140MT-C3E-C16	140M-D8E-C16 140MT-D9E-C16	140M-F8E-C16	3441
20AB015	C	5	3	16	2.9	8.6	9.6	13.3	20	35	20	70	70	30	140M-C2E-C20 140MT-C3E-C20	140M-D8E-C20 140MT-D9E-C20	140M-F8E-C20	3441
20AB022	D	7.5	5	23.3	4.2	12.7	13.9	19.0	30	50	30	100	100	30	—	140M-D8E-C25 140MT-D9E-C25	140M-F8E-C25	5098
20AB028	D	10	7.5	29.8	5.4	16.1	19	25.3	40	70	40	125	125	50	—	—	140M-F8E-C32	5098
20AB042	D	15	10	39.8	7.2	21.5	27.8	37	60	100	60	175	175	70	—	—	140M-F8E-C45	5098
20AB054	E	20	15	57.5	10.4	31.1	36.2	48.3	80	125	80	200	200	100	—	—	—	—
20AB070	E	25	20	72.3	13.0	39.1	46.6	62	90	175	90	300	300	100	—	—	—	—

240V AC Input

20AB2P2	A	0.5	0.33	2.5	0.6	1.1	1.2	1.7	3	4.5	3	8	15	3	140M-C2E-B25 140MT-C3E-B25	140M-D8E-B25 140MT-D9E-B25	—	3441
20AB4P2	A	1	0.75	4.8	1	2.1	2.4	3.2	6	9	6	15	15	7	140M-C2E-B63 140MT-C3E-B63	140M-D8E-B63 140MT-D9E-B63	—	3441
20AB6P8	B	2	1.5	8.7	1.8	3.4	4.5	6	15	15	15	25	25	15	140M-C2E-C10 140MT-C3E-C10	140M-D8E-C10 140MT-D9E-C10	140M-F8E-C10	3441
20AB9P6	B	3	2	12.2	2.6	4.8	5.3	7.2	20	20	20	35	35	15	140M-C2E-C16 140MT-C3E-C16	140M-D8E-C16 140MT-D9E-C16	140M-F8E-C16	3441
20AB015	C	5	3	13.9	2.9	7.7	8.7	11.6	20	30	20	60	60	30	140M-C2E-C16 140MT-C3E-C16	140M-D8E-C16 140MT-D9E-C16	140M-F8E-C16	3441
20AB022	D	7.5	5	19.9	4.2	11	12.2	16.5	25	45	25	80	80	30	—	140M-D8E-C25 140MT-D9E-C25	140M-F8E-C25	5098
20AB028	D	10	7.5	25.7	5.4	14	16.5	22	35	60	35	110	110	50	—	—	140M-F8E-C32	5098
20AB042	D	15	10	38.7	8.1	21	23.1	31.5	50	90	50	150	150	50	—	—	140M-F8E-C45	5098
20AB054	E	20	15	49.8	10.4	27	31.5	42	60	100	60	200	200	100	—	—	—	—
20AB070	E	25	20	64.5	13.4	35	40.5	54	90	150	90	275	275	100	—	—	—	—

See page 26 for notes.

400/480V AC Single-phase Input Drive Ratings and Input Protection Devices

Cat. No.	Frame (1)	Hp Rating		Input Ratings		Output Current Rating [A]			Dual Element Time Delay Fuse [A]		Non-time Delay Fuse [A]		Circuit Breaker [A] (4)	Motor Circuit Protector [A] (6)	140M/MT Motor Protection Circuit Breaker (7) (8)			
		ND	HD	A	kVA	Cont.	60 s	3 s	Min (2)	Max (3)	Min (2)	Max (3)	Max (5)	Max (5)	Available Catalog Numbers (9)			Min Enclosure Volume (in. 3) (10)

400V AC Input

20AC1P3	A	0.37	0.25	1.6	0.6	0.7	0.7	1.0	3	3	3	5	15	3	140M-C2E-B16 140MT-C3E-B16	—	—	3441
20AC2P1	A	0.75	0.55	2.5	0.9	1.1	1.2	1.6	4	6	4	8	15	7	140M-C2E-B25 140MT-C3E-B25	140M-D8E-B25 140MT-D9E-B25	—	3441
20AC3P5	A	1.5	1.1	4.3	1.5	1.8	2.3	3	6	6	6	12	15	7	140M-C2E-B63 140MT-C3E-B63	140M-D8E-B63 140MT-D9E-B63	—	3441
20AC5P0	B	2.2	1.5	6.5	2.3	2.5	2.8	3.8	10	10	10	20	20	15	140M-C2E-C10 140MT-C3E-C10	140M-D8E-C10 140MT-D9E-C10	140M-F8E-C10	3441
20AC8P7	B	4	3	11.3	3.9	4.4	5.0	6.6	15	17.5	15	30	30	15	140M-C2E-C16 140MT-C3E-C16	140M-D8E-C16 140MT-D9E-C16	140M-F8E-C16	3441
20AC011	C	5.5	4	11	3.8	5.8	6.5	8.7	15	25	15	45	40	15	140M-C2E-C16 140MT-C3E-C16	140M-D8E-C16 140MT-D9E-C16	140M-F8E-C16	3441

400/480V AC Single-phase Input Drive Ratings and Input Protection Devices

Cat. No.	Frame (1)	Hp Rating		Input Ratings		Output Current Rating [A]			Dual Element Time Delay Fuse [A]		Non-time Delay Fuse [A]		Circuit Breaker [A] (4)	Motor Circuit Protector [A] (6)	140M/MT Motor Protection Circuit Breaker (7) (8)			
		ND	HD	A	kVA	Cont.	60 s	3 s	Min (2)	Max (3)	Min (2)	Max (3)	Max (5)	Max (5)	Available Catalog Numbers (9)		Min Enclosure Volume (in. 3) (10)	
20AC015	C	7.5	5.5	15.1	5.2	7.7	8.6	11.6	20	30	20	60	60	20	140M-C2E-C16 140MT-C3E-C16	140M-D8E-C16 140MT-D9E-C16	140M-F8E-C16	3441
20AC022	D	11	7.5	21.9	7.6	11	12.1	16.5	30	45	30	80	80	30	—	140M-D8E-C25 140MT-D9E-C25	140M-F8E-C25	5098
20AC030	D	15	11	30.3	10.5	15	16.5	22.5	40	60	40	120	120	50	—	—	140M-F8E-C32	5098
20AC037	D	18.5	15	35	12.2	18.5	22.5	30	50	80	50	125	140	50	—	—	140M-F8E-C45	5098
20AC043	D	22	18.5	40.7	14.1	21.5	28	37	60	90	60	150	160	70	—	—	—	—
20AC060	E	30	22	56.8	19.7	30	33	45	80	125	80	225	240	80	—	—	—	—
20AC072	E	37	30	68.9	23.9	36	45	60	90	150	90	250	280	100	—	—	—	—
480V AC Input																		
20AD1P1	A	0.5	0.33	1.3	0.6	0.6	0.6	0.8	3	3	3	4	15	3	140M-C2E-B16 140MT-C3E-B16	—	—	3441
20AD2P1	A	1	0.75	2.4	1	1.1	1.2	1.6	3	6	3	8	15	3	140M-C2E-B25 140MT-C3E-B25	140M-D8E-B25 140MT-D9E-B25	—	3441
20AD3P4	A	2	1.5	3.8	1.6	1.7	2.3	3	6	6	6	12	15	7	140M-C2E-B40 140MT-C3E-B40	140M-D8E-B40 140MT-D9E-B40	—	3441
20AD5P0	B	3	2	5.6	2.4	2.5	2.6	3.8	10	10	10	20	20	15	140M-C2E-B63 140MT-C3E-B63	140M-D8E-B63 140MT-D9E-B63	—	3441
20AD8P0	B	5	3	9.8	4.2	4	4.4	6	15	15	15	30	30	15	140M-C2E-C10 140MT-C3E-C10	140M-D8E-C10 140MT-D9E-C10	140M-F8E-C10	3441
20AD011	C	7.5	5	9.5	4	5.5	6.1	8.3	15	20	15	40	40	15	140M-C2E-C16 140MT-C3E-C16	140M-D8E-C16 140MT-D9E-C16	140M-F8E-C16	3441
20AD014	C	10	7.5	12.5	5.2	7	8.3	11	20	30	20	50	50	20	140M-C2E-C16 140MT-C3E-C16	140M-D8E-C16 140MT-D9E-C16	140M-F8E-C16	3441
20AD022	D	15	10	19.9	8.3	11	12.1	16.5	25	45	25	80	80	30	—	140M-D8E-C25 140MT-D9E-C25	140M-F8E-C25	5098
20AD027	D	20	15	24.8	10.3	13.5	16.5	22	35	60	35	100	100	50	—	—	140M-F8E-C32	5098
20AD034	D	25	20	31.2	13	17	20.3	27	40	70	40	125	125	50	—	—	140M-F8E-C45	5098
20AD040	D	30	25	36.7	19.9	20	25.5	34	50	90	50	150	150	50	—	—	140M-F8E-C45	5098
20AD052	E	40	30	47.7	12.8	26	30	40	60	110	60	200	200	70	—	—	—	—
20AD065	E	50	40	59.6	24.8	32.5	39	52	80	125	80	250	250	100	—	—	—	—

See page 26 for notes.

600V AC Single-phase Input Drive Ratings and Input Protection Devices

Cat. No.	Frame (1)	Hp Rating		Input Ratings		Output Current Rating [A]			Dual Element Time Delay Fuse [A]		Non-time Delay Fuse [A]		Circuit Breaker [A] (4)	Motor Circuit Protector [A] (6)	140M/MT Motor Protection Circuit Breaker (7) (8)			
		ND	HD	A	kVA	Cont.	60 s	3 s	Min (2)	Max (3)	Min (2)	Max (3)	Max (5)	Max (5)	Available Catalog Numbers (9)		Min Enclosure Volume (in. 3) (10)	
600V AC Input																		
20AE0P9	A	0.5	0.33	1.3	0.7	0.5	0.6	0.7	3	3	3	3.5	15	3	140M-C2E-B16 140MT-C3E-B16	—	—	3441
20AE1P7	A	1	0.75	1.9	1	0.9	1	1.3	3	6	3	6	15	3	140M-C2E-B25 140MT-C3E-B25	140M-D8E-B25 140MT-D9E-B25	—	3441
20AE2P7	A	2	1.5	3	1.6	1.4	1.8	2.4	4	6	4	10	15	7	140M-C2E-B40 140MT-C3E-B40	140M-D8E-B40 140MT-D9E-B40	—	3441
20AE3P9	B	3	2	4.4	2.3	2	2.2	3	6	8	6	15	15	7	—	140M-D8E-B63 140MT-D9E-B63	—	3441
20AE6P1	B	5	3	7.5	3.9	3.1	3.4	4.6	10	12	10	20	20	15	—	140M-D8E-C10 140MT-D9E-C10	140M-F8E-C10	3441
20AE9P0	C	7.5	5	7.7	4	4.5	5	6.8	10	20	10	35	35	15	—	140M-D8E-C10 140MT-D9E-C10	140M-F8E-C10	3441
20AE011	C	10	7.5	9.8	5.1	5.5	6.8	9	15	20	15	40	40	15	—	140M-D8E-C16 140MT-D9E-C16	140M-F8E-C16	3441
20AE017	D	15	10	15.3	8	8.5	9.4	12.8	20	35	20	60	60	30	—	—	140M-F8E-C20	5098
20AE022	D	20	15	20	10.4	11	12.8	17	25	45	25	80	80	30	—	—	140M-F8E-C25	5098
20AE027	D	25	20	24.8	12.9	13.5	16.5	22	35	60	35	100	100	50	—	—	140M-F8E-C25	5098
20AE032	D	30	25	29.4	15.3	16	20.3	27	40	70	40	125	125	50	—	—	140M-F8E-C32	5098
20AE041	E	40	30	37.6	19.6	20.5	24	32	50	90	50	150	150	100	—	—	—	—
20AE052	E	50	40	47.7	24.8	26	30.8	41	60	110	60	200	200	100	—	—	—	—

- (1) For IP66 (NEMA /UL Type 4X/12) enclosures, drives listed as Frame A increase to Frame B and drives listed as Frame C increase to Frame D.
- (2) Minimum protection device size is the lowest rated device that supplies maximum protection without nuisance tripping.
- (3) Maximum protection device size is the highest rated device that supplies drive protection. For US NEC, minimum size is 125% of motor FLA. Ratings that are shown are maximum.
- (4) Circuit Breaker - inverse time breaker. For US NEC, minimum size is 125% of motor FLA. Ratings that are shown are maximum.
- (5) Maximum allowable rating by US NEC. Exact size must be chosen for each installation.
- (6) Motor Circuit Protector - instantaneous trip circuit breaker. For US NEC, minimum size is 125% of motor FLA. Ratings that are shown are maximum.
- (7) Bulletin 140M/MT devices with adjustable current range must have the current trip set to the minimum range that the device does not trip.
- (8) Manual Self-Protected (Type E) Combination Motor Controller, UL Listed for 208V Wye or Delta, 240V Wye or Delta, 480V Y/277 or 600V Y/347. Not UL Listed for use on 480V or 600V Delta/Delta, corner ground, or high-resistance ground systems.
- (9) The A1C ratings of the Bulletin 140M/MT devices can vary. See publication [140-TD005](#) or [140M-TD002](#).
- (10) When using a Manual Self-Protected (Type E) Combination Motor Controller, the drive must be installed in a ventilated or non-ventilated enclosure with the minimum volume that is specified in this column. Application-specific thermal considerations can require a larger enclosure.

Disconnecting MOVs and Common Mode Capacitors

Before proceeding, be sure that all power to the drive has been removed.



ATTENTION: Only qualified personnel familiar with adjustable frequency AC drives and associated machinery can perform maintenance/repair of the system. Failure to comply can result in personal injury and/or equipment damage.



ATTENTION: To avoid an electric shock hazard, verify that the voltage on the bus capacitors has discharged before performing any work on the drive. Measure the DC bus voltage at the +DC and –DC terminals of the Power Terminal Block (refer to [Frame A, B, C, D Power Terminal Block, and DC Bus Test Points](#) on page 19 for location). The voltage must be zero.



ATTENTION: The following information is merely a guide for proper installation. Rockwell Automation cannot assume responsibility for the compliance or the noncompliance to any code, national, local or otherwise for the proper installation of this drive or associated equipment. A hazard of personal injury and/or equipment damage exists if codes are ignored during installation.

IMPORTANT To guard against unstable operation and/or damage, you must configure the drive as shown in [Recommended Power Jumper Configurations](#) on page 27.

The PowerFlex 70 drive contains protective MOVs and common mode capacitors that are referenced to ground (see below).

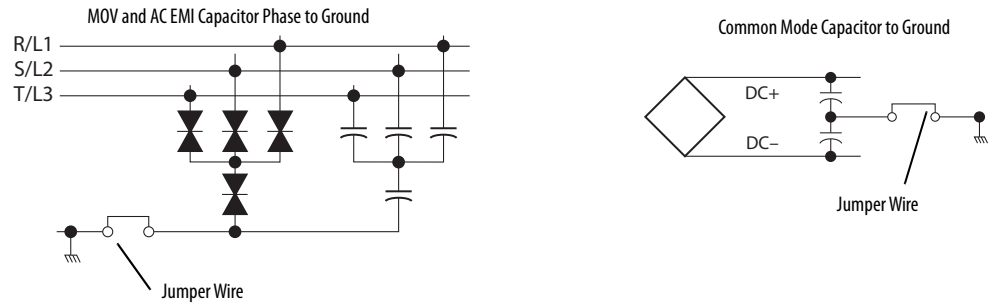

IMPORTANT The common mode capacitor to ground is not installed on A or B frames as standard. It is available for the B frame if the EMF filter option is installed. The common mode capacitor to ground comes standard on C, D, and E frames.

IMPORTANT All PowerFlex 70 240V, 480V, and 600V AC input drives are shipped with the DC bus common mode capacitors that are referenced to ground. Specific drive catalog numbers are listed.

Voltage	Cat. No.
240	20AB...
480	20AD...
600	20AE...

See Wiring and Grounding Guidelines for PWM AC Drives, publication [DRIVES-IN001](#) for information on ungrounded systems.

Recommended Power Jumper Configurations

Power Source Type ⁽¹⁾	MOV/Input Filter Caps ⁽²⁾	DC Bus Common Mode Caps	Benefits of Correct Configuration on Power Source Type
Unknown	Connected	Disconnected	See solid and non-solid ground points below
Solid ground <ul style="list-style-type: none"> AC fed, solidly grounded DC fed from passive rectifier that has an AC source and solid ground 	Connected	Connected	<ul style="list-style-type: none"> UL compliance Reduced electrical noise Most stable operation EMC compliance Reduced voltage stress on components and motor bearings
Non-solid ground <ul style="list-style-type: none"> AC fed ungrounded Impedance grounded High resistive ground B phase ground Regenerative unit such as common DC bus supply and brake DC fed from an active converter 	Disconnected	Disconnected	Helps to avoid severe equipment damage when a ground fault occurs.

(1) It is highly recommended to accurately determine the power source type and then configure appropriately.

(2) When MOVs are disconnected, the power system must have its own transient protection to help ensure known and controlled voltages.

To connect or disconnect these devices, refer to pages [28](#) through [30](#).

IMPORTANT Common mode capacitors are required to conform with the EMC Directive. Removing the common mode capacitors causes the drive to be non-compliant with the EMC Directive.

In addition to the configurations described in this section, install an isolation transformer on an ungrounded distribution system where the line-to-ground voltages on any phase can exceed 125% of the nominal line-to-line voltage. See Wiring and Grounding Guidelines for PWM AC Drives, publication [DRIVES-IN001](#) for more information on impedance grounded and ungrounded systems.

Jumper Installation, Removal, and Storage

PowerFlex 70 drives use plug-in style jumpers. Most drives have a jumper storage area inside the front cover. Store any extra jumpers, or jumpers that have been removed, in this storage area.

In some cases, a protective cover is installed over the jumper pins that extend from the board. If there is a protective cover, remove the cover, install (or remove) the jumper, and replace the cover.

Drive Identification

See the example of the drive nameplate and locate the voltage code, frame, and internal EMC option (frame B drives). Use this information to locate the proper procedure in the following tables.

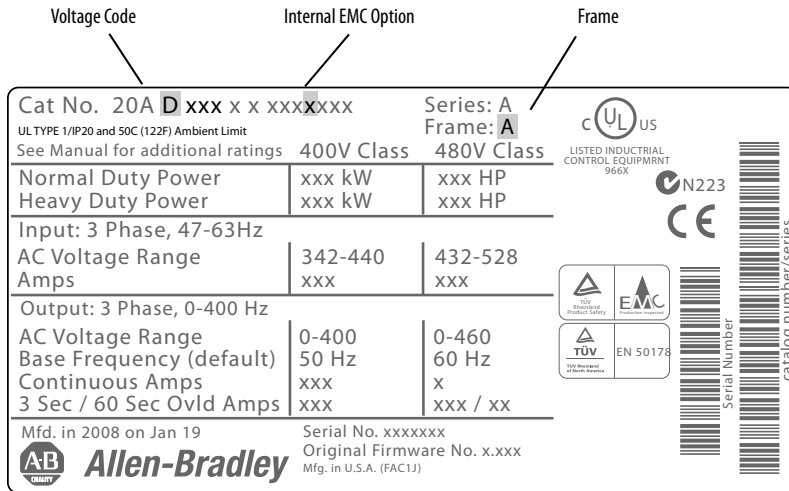

Jumper Settings and Locations

Frame	Voltage Code	Factory Default Jumper Settings		Power Source Type
		MOV / Input Filter Caps	DC Bus Common Mode Caps	
A	B C D E	JP2/JP3 Installed	Not applicable	<p>Solid ground Verify that the jumper at "JP2/JP3" is installed.</p> <p>Non-solid ground Remove the jumper at "JP2/JP3."</p>

Frame	Voltage Code	Factory Default Jumper Settings		Power Source Type
		MOV / Input Filter Caps	DC Bus Common Mode Caps	
B	B D E	JP2/JP3 Installed	JP5/JP6 Installed	<p>Important: The internal EMC filter (input filter) is a factory-installed option on frame B drives. If the option is installed, the drive cannot be used on a non-solid ground power source.</p> <p>To verify: an extra "R, S, T" terminal block is present if the option is installed (as shown). Additionally, the 13th character of the nameplate catalog number is "A" (see page 28).</p> <p>Solid ground Verify that the jumpers at both locations are installed (JP2/JP3 and JP5/JP6).</p> <p>Non-solid ground Remove the jumpers at "JP2/JP3" and "JP5/JP6." In addition, verify that the input filter option is not installed.</p>
	C	JP2/JP3 Installed	JP5/JP6 Installed	
C	B D E	JP2/JP3 Installed	JP3A/JP3B Installed	<p>Solid ground Verify that the jumpers at both locations (JP2/JP3 and JP3A/JP3B) are installed.</p> <p>Non-solid ground Remove the jumpers at "JP2/JP3" and "JP3A/JP3B".</p>
	C	JP2/JP3 Installed	JP3A/JP3B Installed	

Frame	Voltage Code	Factory Default Jumper Settings		Power Source Type
		MOV / Input Filter Caps	DC Bus Common Mode Caps	
D	B D E	JP2/JP3 Installed	JP3A/JP3B Installed	Solid ground Verify that the jumpers at both locations (JP2/JP3 and JP3A/JP3B) are installed.
	C	JP2/JP3 Installed	JP3A/JP3B Installed	Non-solid ground Remove the jumpers at "JP2/JP3" and "JP3A/JP3B".
E	B D E	JP1/JP2 Installed	JP3/JP4 Installed	Solid ground Verify that the jumpers at both locations (JP1/JP2 and JP3/JP4) are installed.
	C	JP1/JP2 Installed	JP3/JP4 Installed	Non-solid ground Remove the jumpers at "JP1/JP2" and "JP3/JP4."

Step 4: I/O Wiring

Important points to remember about I/O wiring:

- Use copper wire. Wire gauge requirements and recommendations are based on 75 °C (167 °F). Do not reduce wire gauge when you are using higher temperature wire.
- Wire with an insulation rating of 600V or greater.
- Control and signal wires must be separated from power wires by at least 0.3 m (1 ft).

IMPORTANT I/O terminals that are labeled “(-)” Digital In Common or “Common” are not connected to earth ground and are designed to greatly reduce common mode interference. Grounding these terminals can cause signal noise.



ATTENTION: Hazard of personal injury or equipment damage exists when using bipolar input sources. Noise and drift in sensitive input circuits can cause unpredictable changes in motor speed and direction. Use speed command parameters to help reduce input source sensitivity.

Typical I/O Terminal Block Location (B Frame Shown)

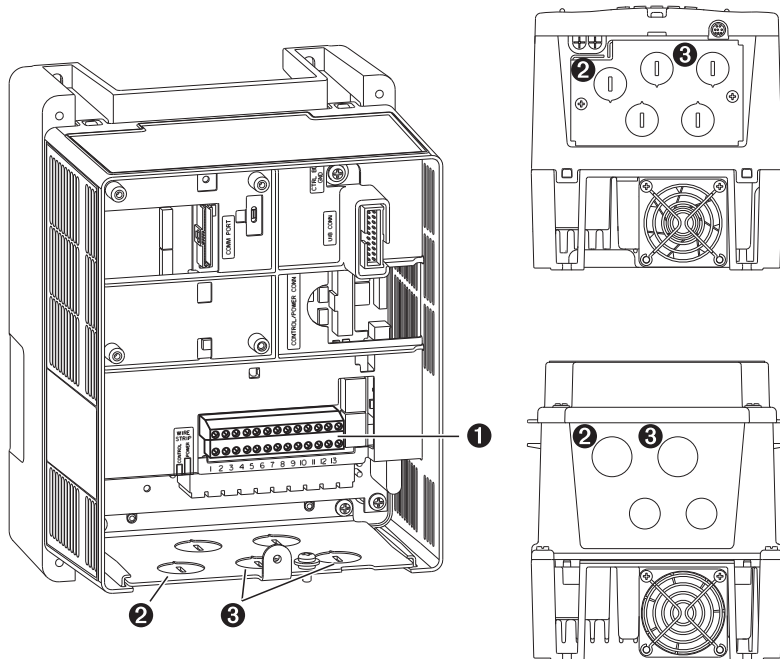

I/O Terminal Block Specifications

No.	Name	Description	Wire Size Range ⁽¹⁾		Torque	
			Max	Min	Max	Recommended
1	I/O terminal block	Signal and control connections	1.5 mm ² (16 AWG)	0.05 mm ² (30 AWG)	0.55 N·m (4.9 lb·in)	0.5 N·m (4.4 lb·in)

(1) Maximum / Minimum that the terminal block can accept - these are not recommendations.

Wire Routing Recommendations

No.	Description
2	Suggested entry for communication wiring.
3	Suggested entry for I/O and control wiring.

I/O Terminal Positions

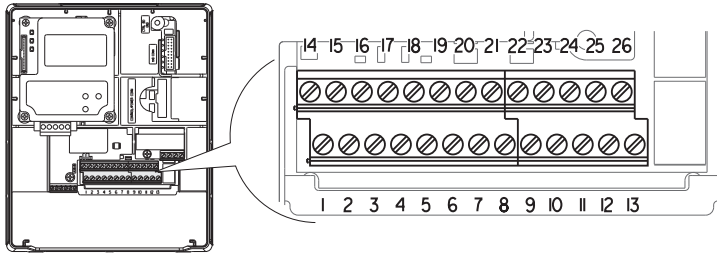

I/O Terminal Designations – Enhanced Control

No.	Signal	Factory Default	Description	Related Parameters
1	Digital In 1	Stop – CF (CF = Clear Fault)	11.2 mA at 24V DC 19.2V minimum on state 3.2V maximum off state Important: Use only 24V DC, not suitable for 115V AC circuitry. Inputs can be wired as sink or source. Important: Digital inputs are not designed to work with a pulsed source.	361...366
2	Digital In 2	Start		
3	Digital In 3	Auto/Man		
4	Digital In 4	Speed Sel 1		
5	Digital In 5	Speed Sel 2		
6	Digital In 6	Speed Sel 3		
7	24V Common	–	Drive supplied power for Digital In 1...6 inputs. Not intended for use on circuits outside of the drive. 150 mA maximum load.	–
8	Digital In Common	–		
9	+24V DC	–		
10	+10V DC Pot Reference	–	2 k ohm minimum load.	–
11	Digital Out 1 – N.O. ⁽¹⁾	NOT Fault	Max resistive load 250V AC / 30V DC 50VA / 60 W Min DC load 10 μA, 10 mV DC	380...387
12	Digital Out 1 Common			
13	Digital Out 1 – N.C. ⁽¹⁾	Fault	Max inductive load 250V AC / 30V DC 25VA / 30 W	
14	Analog In 1 (– Volts)	(2) TB Man Ref Voltage – Reads value at 14 & 15	Non-isolated, 0...+10V, 10 bit, 100k ohm input impedance. ⁽³⁾	320...327
15	Analog In 1 (+ Volts)			
16	Analog In 1 (– Current)		Non-isolated, 0...20 mA, 10 bit, 100 ohm input impedance. ⁽³⁾	
17	Analog In 1 (+ Current)			
18	Analog In 2 (– Volts)	(2) Speed Ref A Voltage – Reads value at 18 & 19	Isolated, bipolar, differential, 0...+10V unipolar (10 bit) or ±10V bipolar (10 bit and sign), 100k ohm input impedance. ⁽⁴⁾	
19	Analog In 2 (+ Volts)			
20	Analog In 2 (– Current)		Isolated, 0...20 mA, 10 bit, and sign, 100 ohm input impedance. ⁽⁴⁾	
21	Analog In 2 (+ Current)			
22	10V Pot Common Analog Out (– Volts) Analog Out (– Current)	(2) Output Freq	0...+10V, 10 bit, 10k ohm (2k ohm minimum) load. 0...20 mA, 10 bit, 400 ohm maximum load. Referenced to chassis ground. Common if internal 10V supply (terminal 10) is used.	340...344
23	Analog Out (+ Volts) Analog Out (+ Current)			
24	Digital Out 2 – N.O. ⁽¹⁾	Run	See description at No.s 11...13.	380...387
25	Digital Out 2 Common			
26	Digital Out 2 – N.C. ⁽¹⁾	NOT Run		

- (1) Contacts shown in unpowered state. Any relay that is programmed as fault or alarm energizes (pick up) when power is applied to drive and de-energizes (drop out) when fault or alarm exists. Relays selected for other functions energize when the condition exists, and de-energize when the condition is removed.
- (2) These inputs/outputs are dependent on a number of parameters. See the Related Parameters column in [I/O Terminal Designations – Enhanced Control](#).
- (3) Differential isolation - external source must be less than 10V regarding PE.
- (4) Differential isolation - external source must be maintained at less than 160V regarding PE. Input provides high common mode immunity.

I/O Wiring Examples

This section shows examples of typical I/O wiring.

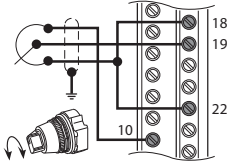
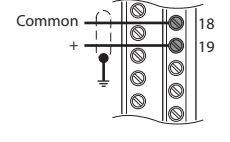
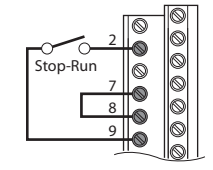
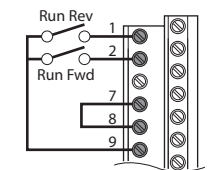
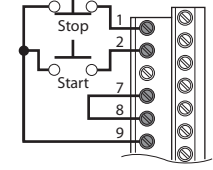
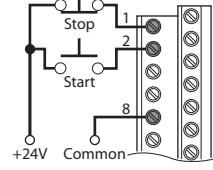
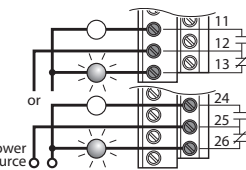
Input/Output	Connection Example	Required Parameter Settings
<p>Potentiometer unipolar speed reference 10k Ohm pot. recommended (2k Ohm minimum)</p>		<p>Select speed reference source: Param. 090 = 2 "Analog In 2" Adjust Scaling: Param. 091, 092, 322, 323 Check results: Param. 017</p>
<p>Analog input unipolar speed reference 0...+10V Input</p>		<p>Default speed reference source: Param. 090 = 2 "Analog In 2" Adjust Scaling: Param. 091, 092, 325, 326 Check results: Param. 017</p>
<p>Two-wire control non-reversing⁽¹⁾</p>	<p>Internal supply</p> 	<p>Disable Digital Input 1: Param. 361 = 0 "Not Used" Set Digital Input 2: Param. 362 = 7 "Run"</p>
<p>Two-wire control reversing⁽¹⁾</p>	<p>Internal supply</p> 	<p>Set Digital Input 1: Param. 361 = 9 "Run Reverse" Set Digital Input 2: Param. 362 = 8 "Run Forward"</p>
<p>Three-wire control⁽¹⁾</p>	<p>Internal supply</p> 	<p>Use factory default parameter settings. Digital Input 1: Param. 361 = 4 "Stop - CF" Digital Input 2: Param. 362 = 5 "Start"</p>
<p>Three-wire control⁽¹⁾</p>	<p>External supply</p> 	<p>Use factory default parameter settings. Digital Input 1: Param. 361 = 4 "Stop - CF" Digital Input 2: Param. 362 = 5 "Start"</p>
<p>Digital output Form C relays energized in normal state</p>		<p>Select source: Use factory default parameter settings. Digital Out1 Sel: Param. 380 = 1 "Fault" Digital Out2 Sel: Param. 384 = 4 "Run"</p>

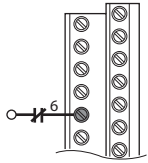
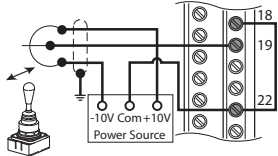
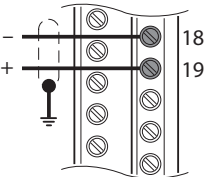
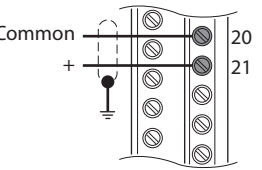
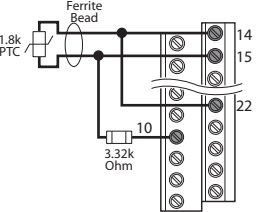
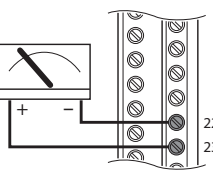
Input/Output	Connection Example	Required Parameter Settings
<p>Enable input Shown in enabled state. Important: Digital inputs are not designed to work with a pulsed source.</p>		<p>Param. 366 = 1 "Enable" For dedicated hardware enable, remove enable jumper (see page 35)</p>
<p>Joystick bipolar speed reference ±10V input</p>		<p>Set direction mode: Param. 090 = 2 "Analog In 2" Param. 190 = 1 "Bipolar" Adjust scaling: Param. 091, 092, 325, 326 Check results: Param. 017</p>
<p>Analog input bipolar speed reference ±10V input</p>		<p>Adjust scaling: Param. 091, 092, 325, 326 Check results: Param. 017</p>
<p>Analog input unipolar speed reference 0...20 mA input</p>		<p>Configure input for current: Param. 320, Bit #1 = 1 "Current" Adjust scaling: Param. 091, 092, 325, 326 Check results: Param. 017</p>
<p>Analog input, positive temperature coefficient PTC OT set > 5V PTC OT cleared < 4V PTC Short < 0.2V</p>		<p>Set Fault Config 1: Param. 238, Bit #7 = 1 "Enabled" Set Alarm Config 1: Param. 259, Bit #11 = 1 "Enabled"</p>
<p>Analog output unipolar 0...+10V output. Can drive a 2k Ohm load (25 mA short circuit limit) 0...20 mA output. 400 Ohm max load.</p>		<p>Select source value: Param. 342 Adjust scaling: Param. 343, 344</p>

(1) Digital inputs can be wired for 2-wire or 3-wire start/stop control. Three-wire control requires separate Start and Stop signals. Two-wire control requires one input signal configured Run-Hi/Stop-Lo.

Hardware Enable Circuitry

By default, you can program a digital input as an enable input. The status of this input is interpreted by drive software. If the application requires the drive to be disabled without software interpretation, a hardware enable configuration is used. To use the hardware enable configuration, remove the enable jumper (ENBL JMP) and connect the enable input to Digital In 6 (see below).

1. Remove the drive cover.
2. Locate and remove the enable jumper on the main control board (see the diagram).
3. Connect the enable to Digital In 6 (see [I/O Terminal Designations – Enhanced Control](#) on page 32).

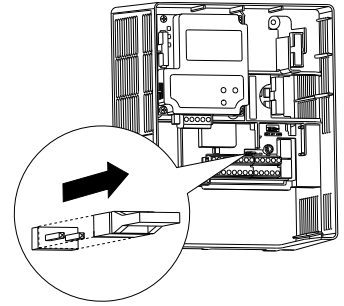

Safe Torque Off Board Option

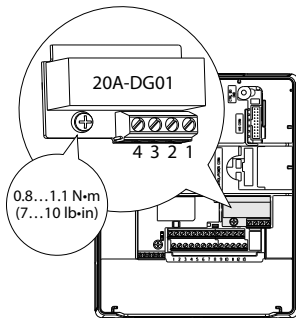

The optional PowerFlex Safe Torque Off board, when used with suitable safety components, provides protection according to EN ISO 13849-1 and EN 62061 for Safe Torque Off and protection against restart. The PowerFlex safe torque off option is just one safety control system. All components in the system must be chosen and applied correctly, to achieve the desired level of operator safeguarding.

IMPORTANT The drive enable digital input is a solid-state circuit. The safety outputs on the safety module must not be configured for pulsed/safety pulse test.

IMPORTANT The drive ships with the hardware enable jumper (ENBL JMP) installed. You must remove the jumper if you are using the DriveGuard Safe Torque Off option. If you do not remove the jumper, the drive faults when a start command is issued.

Terminal Description

No.	Signal	Description
1	Monitor - N.C.	Normally closed contacts for monitoring relay status. Maximum Resistive load: 250V AC / 30V DC / 50VA / 60 W Maximum Inductive load: 250V AC / 30V DC / 25VA / 30 W
2	Common - N.C.	
3	+24V DC	Connections for user-supplied power to energize coil.
4	24V Common	

For detailed information on installing and wiring a safety relay system, refer to the DriveGuard Safe Torque Off Option (Series B) for PowerFlex 40P and PowerFlex 70 AC Drives User Manual, publication [PFLEX-UM003](#).

IMPORTANT If the Safe Torque Off board is removed from the drive, pins 3 and 4 of the Safe Torque Off connector must be jumpered for the drive to run. If the Safe Torque Off board or the jumper is not installed, and the drive is commanded to run, an F111 Enable Hardware fault occurs.

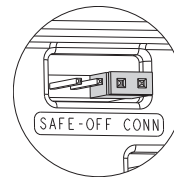

Encoder Interface Option

The optional PowerFlex encoder interface can source 5 volt or 12 volt power and accept 5 volt or 12 volt single-ended differential inputs. The factory default setting is 12 volts.

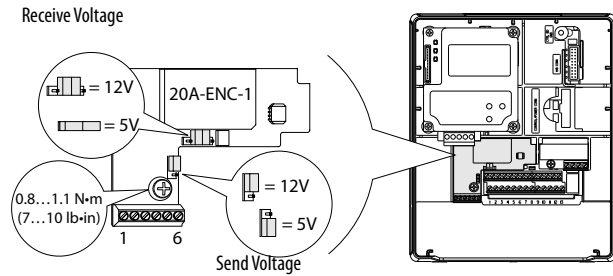

Terminal Description

No.	Signal	Description
1	5V or 12V power	Internal power source 250 mA (isolated).
2	Power return	
3	Encoder B (NOT)	Single channel or quadrature B input.
4	Encoder B	
5	Encoder A (NOT)	Single channel or quadrature A input.
6	Encoder A	

Sample Encoder Wiring

I/O	Connection Example	I/O	Connection Example
Encoder power – internal drive power Internal (drive) 12V DC, 250 mA		Encoder power – external power source	
Encoder signal – single-ended, dual channel		Encoder signal – differential, dual channel	

Encoder Specifications

Topic	Description
Type	Incremental, dual-channel
Supply	5V/12V Configurable ±5%
Quadrature	90° ±27°
Duty Cycle	50% +10%
Requirements	Encoders must be line driver type, quadrature (dual channel), or pulse (single channel), single-ended or differential and capable of supplying a minimum of 10 mA per channel. The encoder interface board accepts 5V or 12V DC square-wave with a minimum high state voltage of 3.5V DC (5V mode) and 7.0V DC (12V mode). Maximum low state voltage is 1V DC (for both 5V and 12V modes). Maximum input frequency is 250 kHz.

Step 5: Start-up Checklist

- This checklist supports the basic start-up menu option. See Start-up Routines on page [42](#) for information on other start-up routines.
- A HIM is required to run the basic start-up routine.
- The basic start-up routine can modify parameter values for analog and digital I/O. See Common I/O Programming Changes on page [44](#).



ATTENTION: Power must be applied to the drive to perform the following start-up procedure. Some of the voltages present are at incoming line potential. To avoid electric shock hazard or damage to equipment, only qualified service personnel can perform the following procedure. Thoroughly read and understand the procedure before beginning.

Prepare For Drive Startup

1. Verify the input supply voltage.
2. Check the output wiring.
3. Check the control wiring.
4. Connect a HIM to DPI Port 1 or 2.

DPI Ports 1 and 2

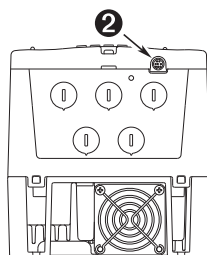
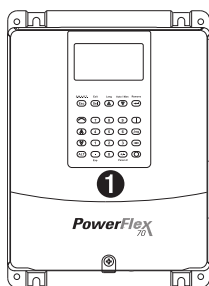

Optional Service Connection Board (SK-M9-SCB1) provides temporary DPI connection with drive cover removed.



5. Apply AC power and control voltages to the drive.

IMPORTANT If any of the six digital inputs are configured to Stop – CF (CF = Clear Fault) or Enable, verify that signals are present or the drive cannot start. See Troubleshooting – Abbreviated Fault and Alarm Listing on page [45](#) for a list of potential digital input conflicts.

If the STS status indicator is not updating green, see Drive Status Indicators on page [44](#).

6. When prompted, select a display language.
The PowerFlex 70 start-up screen displays.
7. Press the enter key to display the start-up menu.
8. Use the arrow keys to highlight **2. Basic**.
9. Press the enter key.

Use the enter key to follow the menu and step you through the start-up routine.

The basic start-up routine asks simple questions and prompts you to input required information. See also Common I/O Programming Changes on page [44](#).

Information About Start-up Motor Tests

Control schemes vary based on the Start/Jog Source that is selected in **Step 3. Motor Tests**.

Start/Jog Source	Control Source Description
Digital inputs	Digital In 1 = Stop / Digital In 2 = Start / Digital In 3 = Jog
Local HIM – Port 1	HIM connected to DPI Port 1 controls Stop / Start / Jog Digital In 1...6 are temporarily disabled during motor tests.
Remote HIM	HIM connected to DPI Port 2 controls Stop / Start / Jog Digital In 1...6 are temporarily disabled during motor tests.

During motor tests and tuning procedures, the drive can modify certain parameter values for proper start-up operation. These values are reset to their original values when startup is complete. The affected parameters are listed here:

- 053
- 080
- 276
- 278
- 361...366

IMPORTANT If power is removed from the drive during the tests without aborting the autotune procedure, these parameters may not reset to their original value. If this situation occurs, reset the drive to factory defaults (see page [44](#)) and repeat the start-up procedure.

Appendix A: Startup and Troubleshooting

This section includes information for starting and troubleshooting the drive.

First Power-up Menu Structure

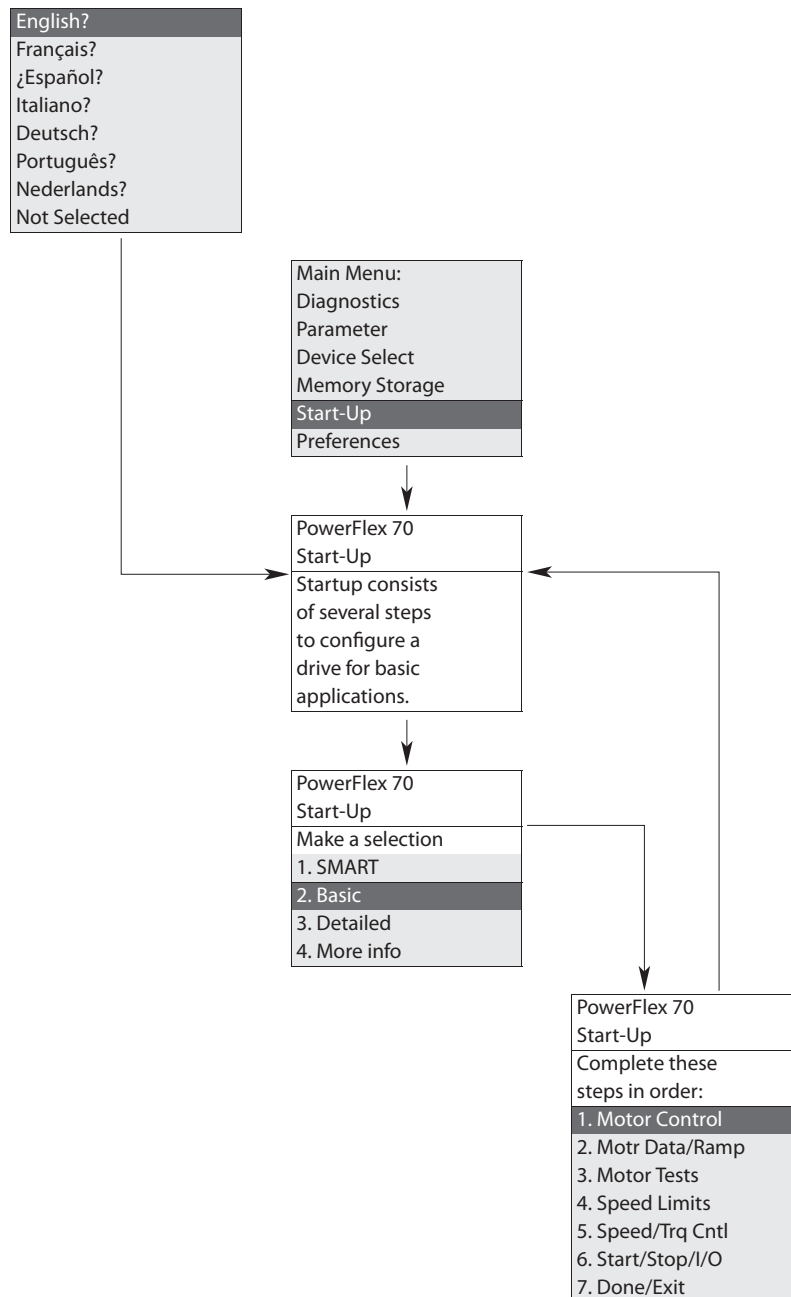

Human Interface Module (HIM) Overview

This section provides information for operating the HIM.

LCD Display Elements

Display	Description
	Direction Drive Status Alarm Auto/Man Information
	Commanded or Output Frequency
Main Menu: Diagnostics Parameter Device Select	Programming / Monitoring / Troubleshooting

HIM Key Functions

Key	Description
	Exit a menu, cancel a change to a parameter value, or acknowledge a fault/alarm.
	Select a digit, select a bit, or enter edit mode in a parameter screen.
	Scroll through options, increase a value, or toggle a bit.
	Scroll through options, decrease a value, or toggle a bit.
	Enter a menu, enter edit mode in a parameter screen, or save a change to a parameter value.
	Access the function that is associated with a programming or numeric key. Provides access to the Large Format Display. See the drive user manual for more information.
	Start the drive.
	Stop the drive or clear a fault.
	Jog the drive.
	Change direction.
	Increase speed.
	Decrease speed.

These keys are active when the HIM is granted Manual Control or Param. 090 [Speed Ref A Sel] / 093 [Speed Ref B Sel] is set to:
 Option 18 "DPI Port 1" for a HIM installed in the drive cover
 or
 Option 19 "DPI Port 2" for a HIM connected by cable for handheld or remote installation option

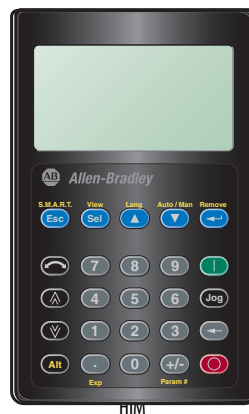



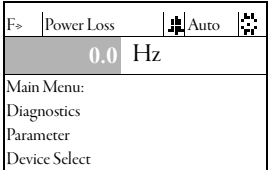





HIM Main Menu

Main Menu Screen	Menu Selections
	Main Menu: Diagnostics Parameter Device Select Memory Storage Start-Up Preferences

ALT Functions

To use an ALT function, start at the Main Menu and press the ALT key, release it, then press the programming key that is associated with one of the following functions that are listed in the table.

ALT Key then	Function	Function Description
	S.M.A.R.T.	Displays the S.M.A.R.T. screen. This function enables the drive parameter values to be quickly programmed by directly accessing the most frequently used drive functions. See the user manual for more information.
	Log In/Out	Log in to change parameter settings. Log out to preserve parameter settings. Change a password.
	View	Enables the selection of how parameters are viewed or detailed information about a parameter or component.
	Device	Select a connected adapter for editing.
	Lang	Displays the language selection screen. The LCD HIM on an architecture class drive enables you to change the display language any time.
	Auto / Man	Switches between Auto and Manual Modes. If the HIM requests Manual Mode, the Speed Reference source is transferred to the HIM.
	Remove	Enables HIM removal without causing a fault if the HIM is not the last controlling device and does not have manual control of the drive.
 	Param #	Enables entry of a parameter number for viewing/editing.

Start-up Routines

The PowerFlex 70 is designed so that startup is simple and efficient. If you have an LCD HIM, two start-up methods are provided. Select the desired start-up routine that is needed for the application:

- **S.M.A.R.T. Start**

This routine lets you quickly configure the drive by programming values for the most commonly used functions (see Running S.M.A.R.T. Start on page 43).

- **Assisted Startup**

This routine prompts you for information to start up a drive for most applications, such as line and motor data, commonly adjusted parameters, and I/O. With enhanced control, two levels of assisted startup are available: basic and detailed (see Running an Assisted Startup on page 43).

IMPORTANT Power must be applied to the drive when viewing or changing parameters. Previous programming can affect the drive status when power is applied.

Enhanced Control Start-up Menu

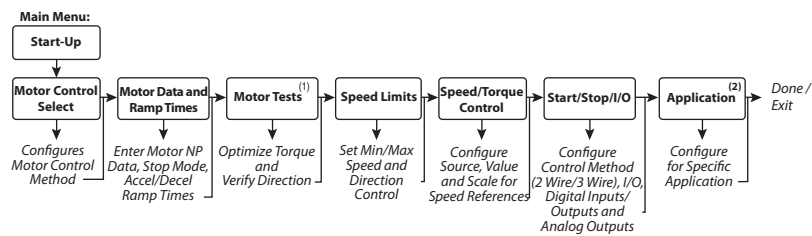

⁽¹⁾ During motor tests and tuning procedures, the drive can modify certain parameter values for proper start-up operation. These values are then reset to their original values when startup is complete. The affected parameters are: 053, 080, 276, 278, and 361...366. If power is removed from the drive during the tests without aborting the autotune procedure, these parameters may not reset to their original value. If this situation occurs, reset the drive to factory defaults (see page 44) and repeat the start-up procedure.

⁽²⁾ Only in Detailed Startup mode.

Running S.M.A.R.T. Start

During a startup, most applications require changes to a few parameters. The LCD HIM on a PowerFlex 70 drive offers S.M.A.R.T. start, and displays the most commonly changed parameters. With these parameters you can set the following functions:

- S – Start Mode and Stop Mode
- M – Minimum and Maximum Speed
- A – Accel Time 1 and Decel Time 1
- R – Reference Source
- T – Thermal Motor Overload

To run a S.M.A.R.T. start routine, follow the steps in this table:

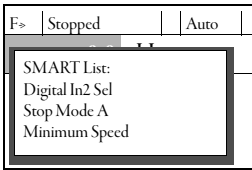
Step	Keys	Example LCD Displays
<ol style="list-style-type: none"> 1. Press ALT and then Esc (S.M.A.R.T.). The S.M.A.R.T. start screen appears. 2. View and change parameter values as desired. For HIM information, see Appendix B. 3. Press Esc to exit the S.M.A.R.T. start. 		

Running an Assisted Startup

IMPORTANT This start-up routine requires an LCD HIM.

The assisted start-up routine prompts you to input required information. Access assisted startup by selecting Start Up from the Main Menu.

To perform an assisted startup, follow the steps in this table:

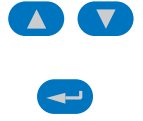
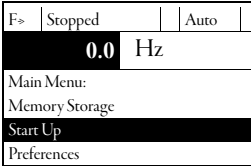
Step	Keys	Example LCD Displays
<ol style="list-style-type: none"> 1. In the Main Menu, press the up arrow or down arrow to scroll to Start Up. 2. Press Enter. 		

IMPORTANT You must select Done/Exit after you complete the start-up routine for the start-up/autotune data to be saved.

Drive Status Indicators

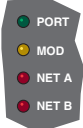
Name	Color	State	Description
	Green	Updating	The drive is ready but is not running, and no faults are present.
		Steady	The drive is running and no faults are present.
	Yellow	Updating, drive stopped	An inhibit condition exists, the drive cannot be started. Check parameter 214 [Start Inhibits].
		Updating, drive running	An intermittent type 1 alarm condition exists. Check parameter 211 [Drive Alarm 1].
		Steady, drive running	A continuous type 1 alarm condition exists. Check parameter 211 [Drive Alarm 1].
	Red	Updating	A fault has occurred.
Steady		A non-resettable fault has occurred.	
	See the communication adapter user manual.		Status of DPI port internal communications (if present).
			Status of communications module (when installed).
			Status of network (if connected).
			Status of secondary network (if connected).

Common I/O Programming Changes

Your application needs can require changing parameters from their factory default settings.

Speed Reference A

Change Speed Reference A from Analog In 2 to Analog In 1 to connect an external potentiometer.

- Set Parameter 090 [Speed Ref A Sel] to option 1, Analog In 1.
Sets the speed reference input to I/O terminals 14 and 15 for voltage, and I/O terminals 16 and 17 for current.
- Set Parameter 096 [TB Man Ref Sel] to option 9, MOP Level.
Minimizes a potential conflict alarm condition. Analog In 2 is not a valid Speed Reference source if selected for any of the following parameters:
 - 117 [Trim In Select]
 - 126 [PI Reference Sel]
 - 128 [PI Feedback Sel]
 - 147 [Current Lmt Sel]
- Set Parameter 091 [Speed Ref A Hi] to the upper value of the desired speed reference range in Hz.
- Set Parameter 092 [Speed Ref A Lo] to the lower value of the desired speed reference range in Hz.

Speed Reference A is now configured for an external potentiometer.

Control Scheme

Change from 3-wire Start/Stop to 2-wire Run/Not Run at Digital In 1 and Digital In 2.

- Set Parameter 361 [Digital In1 Sel] to option 7 Run, or 9 Run Reverse.
- Set Parameter 362 [Digital In2 Sel] to another option such as 8 Run Forward, or 10 Jog.

See I/O wiring examples beginning on page [31](#).

Restoring Factory Defaults

From the HIM Main Menu, select Memory Storage/Reset To Defaults.

Troubleshooting – Abbreviated Fault and Alarm Listing

For a complete listing of faults and alarms, refer to the PowerFlex 70 User Manual, publication [20A-UM001](#).

Abbreviated Fault Table

Fault	No.	Type ⁽¹⁾	Description	Action
Auxiliary Input	2	1	Auxiliary input interlock is open.	Check remote wiring.
Decel Inhibit	24	3	The drive is not following a commanded deceleration because it is attempting to limit bus voltage.	Verify that input voltage is within drive specified limits. Verify that system ground impedance follows proper grounding techniques. Disable bus regulation and/or add dynamic brake resistor and/or extend deceleration time.
FluxAmpsRef Rang	78		The value for flux amps determined by the Autotune procedure exceeds the programmed [Motor NP FLA].	Reprogram [Motor NP FLA] with the correct motor nameplate value. Repeat Autotune.
HW OverCurrent	12	1	The drive output current has exceeded the hardware current limit.	Check programming. Check for excess load, improper DC boost setting, DC brake volts set too high, or other causes of excess current.
IR Volts Range	77		“Calculate” is the autotune default and the value that is determined by the autotune procedure for IR Drop Volts is not in the range of acceptable values.	Reenter motor nameplate data.
Motor Overload	7	1 3	Internal electronic overload trip. Enable/Disable with [Fault Config 1].	An excessive motor load exists. Reduce load so drive output current does not exceed the current set by [Motor NP FLA].
OverSpeed Limit	25	1	Functions such as Slip Compensation or Bus Regulation have attempted to add an output frequency adjustment greater than the value programmed in [Overspeed Limit].	Remove excessive load or overhauling conditions or increase [Overspeed Limit].
OverVoltage	5	1	DC bus voltage exceeded maximum value.	Monitor the AC line for high line voltage or transient conditions. Motor regeneration can also cause a bus overvoltage. Extend the decel time or install dynamic brake option.
SW OverCurrent	36	1	Drive output current has exceeded the 1 ms current rating. This rating is greater than the 3 second current rating and less than the hardware overcurrent fault level. It is typically 200 . . . 250% of the drive continuous rating.	Check for excess load, improper DC boost setting. DC brake volts set too high.

(1) See the PowerFlex 70 User Manual, publication [20A-UM001](#), for a description of fault types.

Abbreviated Alarm Table

Alarm	No.	Type ⁽¹⁾	Description									
Dig In ConflictA	17	2	Digital input functions are in conflict. Combinations that are marked with an "X" cause an alarm.									
				Acc2/Dec2	Accel 2	Decel 2	Jog	Jog Fwd	Jog Rev	Fwd/Rev		
			Acc2 / Dec2		X	X						
			Accel 2	X								
			Decel 2	X								
			Jog					X	X			
			Jog Fwd				X			X		
			Jog Rev				X			X		
Fwd / Rev					X	X						
Dig In ConflictB	18	2	A digital Start input has been configured without a Stop input or other functions are in conflict. Combinations that conflict are marked with an "X" and causes an alarm.									
				Start	Stop-CF	Run	Run Fwd	Run Rev	Jog	Jog Fwd	Jog Rev	Fwd/Rev
			Start			X	X	X		X	X	
			Stop-CF									
			Run	X			X	X		X	X	
			Run Fwd	X		X			X			X
			Run Rev	X		X			X			X
			Jog				X	X				
			Jog Fwd	X		X						
Jog Rev	X		X									
Fwd / Rev				X	X							
Dig In ConflictC	19	2	Multiple physical inputs have been configured to the same input function. Multiple configurations are not allowed for the following input functions: <ul style="list-style-type: none"> • Forward/Reverse, Run Reverse, Bus Regulation Mode B • Speed Select 1, Jog Forward, Acc2 / Dec2 • Speed Select 2, Jog Reverse, Accel 2 • Speed Select 3, Run, Decel 2 • Run Forward, Stop Mode B 									
TB Man Ref Cfct	30	EC	Occurs when: "Auto/Manual" is selected (default) for [Digital In3 Sel], parameter 363 and [TB Man Ref Sel], parameter 96 has been reprogrammed. No other use for the selected analog input can be programmed. Example: If [TB Man Ref Sel] is reprogrammed to "Analog In 2," all factory default uses for "Analog In 2" must be reprogrammed (such as parameters 90, 117, 128 and 179). See the Auto/Manual Examples section of the PowerFlex 70 User Manual, publication 20A-UM001 . To correct: Verify/reprogram the parameters that reference an analog input or Reprogram [Digital In3] to another function or "Unused."									

(1) See PowerFlex 70 User Manual, publication [20A-UM001](#), for a description of alarm types.

Common Symptoms and Corrective Actions

Drive Does Not Start From Start or Run Inputs Wired to the Terminal Block

Cause	Indication	Corrective Action
Drive is Faulted	Updating red status light	Clear fault. <ul style="list-style-type: none"> • Press Stop • Cycle power • Set [Fault Clear] to 1 • "Clear Faults" on the HIM Diagnostic menu
Incorrect input wiring. See page 31 for wiring examples. <ul style="list-style-type: none"> • Two wire control requires Run, Run Forward, Run Reverse or Jog input. • Three wire control requires Start and Stop inputs • Jumper from terminal 7 to 8 is required. 	Updating green status light	Wire inputs correctly and/or install jumper.
Incorrect digital input programming. <ul style="list-style-type: none"> • Mutually exclusive choices have been made (that is, Jog and Jog Forward). • 2-wire and 3-wire programming can be conflicting. • Exclusive functions (for example, direction control) can have multiple inputs that are configured. • Stop is factory default and is not wired. 	None	Program [Digital Inx Sel] for correct inputs. Start or Run programming can be missing.
	Updating yellow status light and "DigIn CflctB" indication on LCD HIM. [Drive Status 2] shows type 2 alarms.	Program [Digital Inx Sel] to resolve conflicts. Remove multiple selections for the same function. Install stop button to apply a signal at stop terminal.
Safe Torque Off Option Installed <ul style="list-style-type: none"> • Hardware Enable Input "Digital In 6" not present. 	Updating yellow status light and "Not Enable" indication on LCD HIM.	Verify correct wiring to "Digital In 6." Check for presence of signal.
Safe Torque Off Option inputs not present.	Updating yellow status light and "Safe Torque Off" indication on LCD HIM.	Wire inputs correctly on Safe Torque Off option terminals 1...4. See the DriveGuard Safe Torque Off Option User Manual, publication PFLEX-UM003 for more information

Drive Does Not Start From the HIM

Cause	Indication	Corrective Action
Drive is programmed for 2-wire control. Human interface module (HIM) Start button is disabled for 2-wire control.	None	If 2-wire control is required, no action is necessary. If 3-wire control is required, program [Digital Inx Sel] for correct inputs.

Drive Does Not Respond to Changes in Speed Command

Cause	Indication	Corrective Action
No value is coming from the source of the command.	LCD HIM Status Line indicates "At Speed" and output is 0 Hz.	<ol style="list-style-type: none"> 1. If the source is an analog input, check wiring and use a meter to check for presence of signal. 2. Check [Commanded Freq] for correct source.
Incorrect reference source has been programmed.	None	<ol style="list-style-type: none"> 1. Check [Speed Ref Source] for the source of the speed reference. 2. Reprogram [Speed Ref A Sel] for correct source.
Incorrect reference source is being selected via remote device or digital inputs.	None	<ol style="list-style-type: none"> 1. Check [Drive Status 1], bits 12 and 13 for unexpected source selections. 2. Check [Dig In Status] to see if inputs are selecting an alternate source. 3. Reprogram digital inputs to correct "Speed Sel x" option.



Motor and/or Drive does Not Accelerate to Commanded Speed

Cause	Indication	Corrective Action
Acceleration time is excessive.	None	Reprogram [Accel Time x].
Excess load or short acceleration times force the drive into current limit, slowing or stopping acceleration.	None	Check [Drive Status 2], bit 10 to see if the drive is in Current Limit. Remove excess load or reprogram [Accel Time x].
Speed command source or value is not as expected.	None	Check for the proper Speed Command by using Drive Does Not Respond to Changes in Speed Command on page 4Z.
Programming is preventing the drive output from exceeding limiting values.	None	Check [Maximum Speed] and [Maximum Freq] to verify that the speed is not limited by programming.

Motor Operation is Unstable

Cause	Indication	Corrective Action
Motor data was incorrectly entered or Autotune was not performed.	None	<ol style="list-style-type: none"> 1. Correctly enter motor nameplate data. 2. Perform "Static" or "Rotate" Autotune procedure.

Manually Clearing Faults

Step	Keys
<ol style="list-style-type: none"> 1. Press Esc to acknowledge the fault. The fault information is removed so that you can use the human interface module (HIM). 2. Address the condition that caused the fault. The cause must be corrected before the fault can be cleared. 3. After corrective action has been taken, clear the fault by one of these methods: <ul style="list-style-type: none"> – Press Stop. – Cycle drive power. – Set parameter 240 [Fault Clear] to "1". – "Clear Faults" on the human interface module (HIM) Diagnostic menu. 	 

Notes:

Notes:

Notes:

Rockwell Automation Support

Use the following resources to access support information.

Technical Support Center	Find help with how-to videos, FAQs, chat, user forums, and product notification updates.	rok.auto/support
Knowledgebase	Access Knowledgebase articles.	rok.auto/knowledgebase
Local Technical Support Phone Numbers	Locate the phone number for your country.	rok.auto/phonesupport
Literature Library	Find installation instructions, manuals, brochures, and technical data publications.	rok.auto/literature
Product Compatibility and Download Center (PCDC)	Download firmware, associated files (such as AOP, EDS, and DTM), and access product release notes.	rok.auto/prdc

Documentation Feedback

Your comments help us serve your documentation needs better. If you have any suggestions on how to improve our content, complete the form at rok.auto/docfeedback.

Rockwell Automation maintains current product environmental compliance information on its website at rok.auto/pec.

Allen-Bradley, PowerFlex, Rockwell Automation, and Rockwell Software are trademarks of Rockwell Automation, Inc. Trademarks not belonging to Rockwell Automation are property of their respective companies.

Rockwell Otomasyon Ticaret A.Ş., Kar Plaza İş Merkezi E Blok Kat:6 34752 İçerenköy, İstanbul, Tel: +90 (216) 5698400

www.rockwellautomation.com

Power, Control and Information Solutions Headquarters

Americas: Rockwell Automation, 1201 South Second Street, Milwaukee, WI 53204-2496 USA, Tel: (1) 414.382.2000, Fax: (1) 414.382.4444

Europe/Middle East/Africa: Rockwell Automation NV, Pegasus Park, De Kleetlaan 12a, 1831 Diegem, Belgium, Tel: (32) 2 663 0600, Fax: (32) 2 663 0640

Asia Pacific: Rockwell Automation, Level 14, Core F, Cyberport 3, 100 Cyberport Road, Hong Kong, Tel: (852) 2887 4788, Fax: (852) 2508 1846



PN-653832

Publication 20A-IN009G-EN-P - April 2022

Supersedes Publication 20A-IN009F-EN-P - April 2018

Copyright © 2022 Rockwell Automation, Inc. All rights reserved. Printed in the U.S.A.