

CLEANTRAY STAINLESS STEEL CABLE TRAY, TYPE 1



INDUSTRY STANDARDS

J A 8A h h ^ Z Y O ^ Z ^ C d # . ' + () &
 I] h e g l v j x i ^ h x a l h ^ z y v h i d ^ t h t j 1 W W h n v h v c z f j ^ e b z c i ^
 \ g l j c y ^ \ x d c y j x i d g d c a r #

C: B 6 6 : B 6 8 1 n e z &

APPLICATION

I] Z ^ 8 a v c 1 g h h i v ^ c a z h h i z z a 8 W W 1 g h ^ h y z h ^ c z y i d ^ e g l i z x i ^
 g m z y x w h c ^ \ ^ c ^ v e e a x m t c h i] v i ^ z f j ^ z [z f j z c i 1 v h] y d l c # 6 ^
 k v g z i n d [h a l e z y i d e ^ i i ^ e h 1 1] t g l c i ! ^ c h y z d g d j i h y z x d k z g
 d e i t c h v a u l h [d g j ^] a r l x j h i d b ^ z y g c h j h ^ e \ h i v c y v g / x m v a l ^
 e g l v j x i v c y h j e e d g h y g z x i t c v a x d c i g l a d [1 v h] y d l c z j z c z #

FEATURES

- 6Yj hiWAZkYZgh
- I dehVcYhYZhXVcXdb eazI ZanideZc
- ; aI XdkZgVcY* %VZ\gZ h a l e z Y X d k Z g b d Y Z a n V k v ^ a W a Z
- E Z g d g m Z Y ^ i i ^ e h v c y h i g / ^] i h z x i t c h
- ; a m l h X d c i v c i] g z X d k Z g d e i t c h [t g l c i ! ^ c h y z v c y d j i h y z
- 8 d c c z x i ^ e \] v g j 1 v g z ^ h ^ e x j y z y 1 1] z v x] b d y z a
- F j V g z g j g ^ a i x] z h

SPECIFICATIONS

- & - \ V j \ z h i v ^ c a z h h i z z a

FINISH

H b d d i] v g h] z y ^ c h j

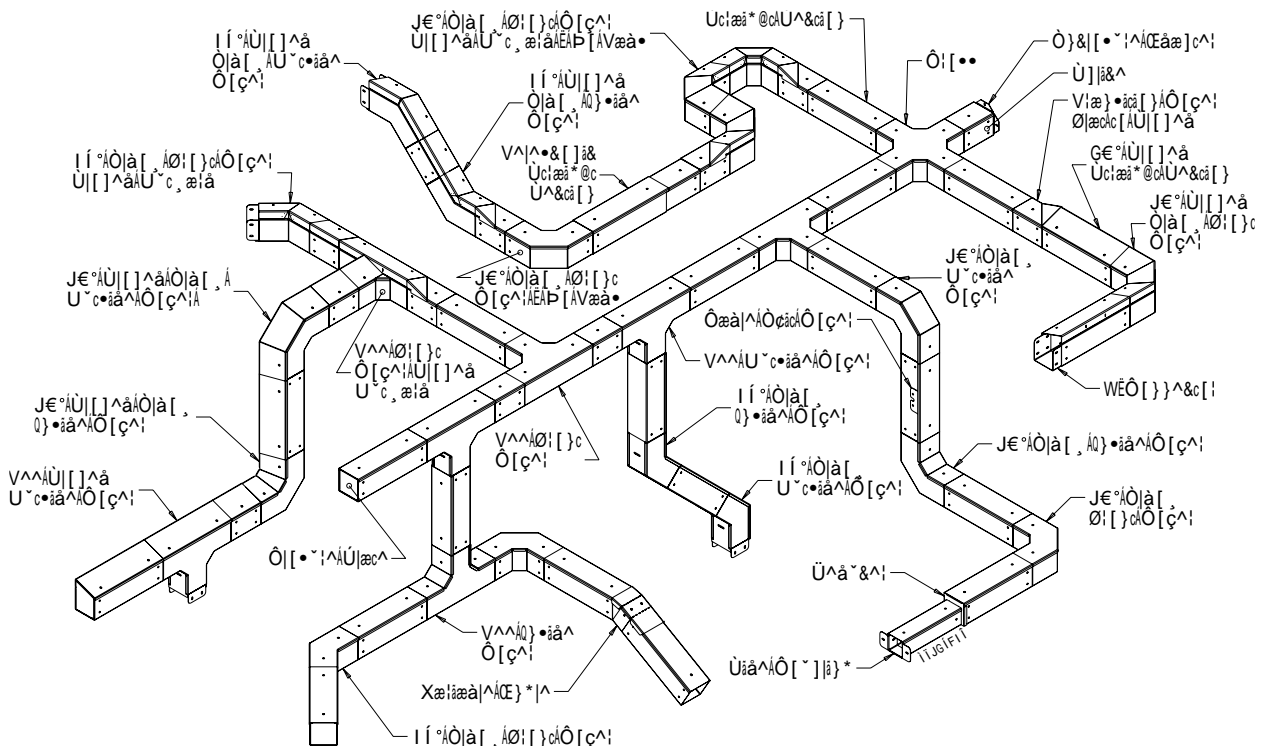

CLEANTRAY STRAIGHT SECTION



High quality stainless steel cable tray straight section.

BULLETIN: F23

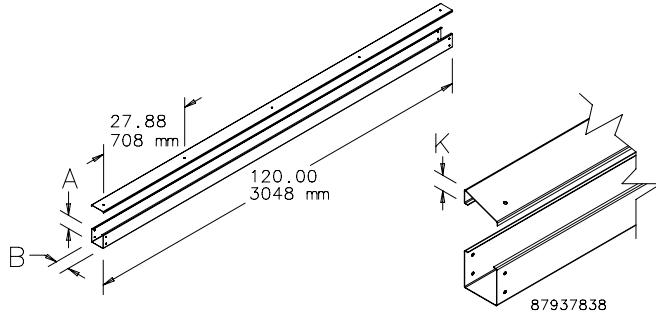

Catalog Number	AxBxC in./mm	Description	K in./mm
CT22120SS	2.00 x 2.00 x 120.00 51 x 51 x 3048	Standard	—
CT33120SS	3.00 x 3.00 x 120.00 76 x 76 x 3048	Standard	—
CT44120SS	4.00 x 4.00 x 120.00 102 x 102 x 3048	Standard	—
CT46120SS	4.00 x 6.00 x 120.00 102 x 152 x 3048	Standard	—
CT66120SS	6.00 x 6.00 x 120.00 152 x 152 x 3048	Standard	—
CT22P120SS	2.00 x 2.00 x 120.00 51 x 51 x 3048	Perforated	—
CT33P120SS	3.00 x 3.00 x 120.00 76 x 76 x 3048	Perforated	—
CT44P120SS	4.00 x 4.00 x 120.00 102 x 102 x 3048	Perforated	—
CT46P120SS	4.00 x 6.00 x 120.00 102 x 152 x 3048	Perforated	—
CT66P120SS	6.00 x 6.00 x 120.00 152 x 152 x 3048	Perforated	—
CTS33120SS	3.00 x 3.00 x 120.00 76 x 76 x 3048	Sloped Top	1.06 24
CTS44120SS	4.00 x 4.00 x 120.00 102 x 102 x 3048	Sloped Top	1.42 36
CTS46120SS	4.00 x 6.00 x 120.00 102 x 152 x 3048	Sloped Top	2.16 55
CTS66120SS	6.00 x 6.00 x 120.00 152 x 152 x 3048	Sloped Top	2.16 55
CTS33P120SS	3.00 x 3.00 x 120.00 76 x 76 x 3048	Sloped Top Perforated	1.06 27
CTS44P120SS	4.00 x 4.00 x 120.00 102 x 102 x 3048	Sloped Top Perforated	1.42 36
CTS46P120SS	4.00 x 6.00 x 120.00 102 x 152 x 3048	Sloped Top Perforated	2.16 55
CTS66P120SS	6.00 x 6.00 x 120.00 152 x 152 x 3048	Sloped Top Perforated	2.16 55

CLEANTRAY DIVIDER STRAIGHT SECTION

High quality stainless steel cable tray divider straight section.

BULLETIN: F23

Catalog Number	H in./mm	L in./mm	Fits Cable Tray Size in./mm
CT33DSS	2.13 54	120 3048	3.00 x 3.00 76 x 76
CT44DSS	3.13 79	120 3048	4.00 x 4.00, 4.00 x 6.00 102 x 102, 102 x 152
CT66DSS	5.13 130	120 3048	6.00 x 6.00 152 x 152

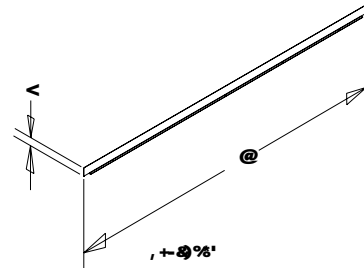

CLEANTRAY TELESCOPIC STRAIGHT SECTION



High quality stainless steel cable tray telescopic straight section.

BULLETIN: F23

Catalog Number	AxB in.	AxB mm
CT22TSS	2.00 x 2.00	51 x 51
CT33TSS	3.00 x 3.00	76 x 76
CT44TSS	4.00 x 4.00	102 x 102
CT46TSS	4.00 x 6.00	102 x 152
CT66TSS	6.00 x 6.00	152 x 152

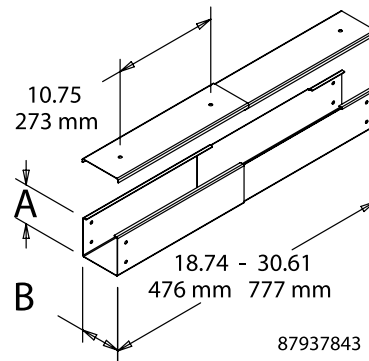

CLEANTRAY DIVIDER, TELESCOPIC STRAIGHT SECTION

Bj hi VZ1gb b ZYid'Zci] #
BULLETIN: F23

Catalog Number	AxB in.	AxB mm
CT33TDSPSS	3.00 x 3.00	76 x 76
CT44TDSPSS	4.00 x 4.00	102 x 102
CT66TDSPSS	6.00 x 6.00	152 x 152

CLEANTRAY 90-DEGREE ELBOWS



BULLETIN: F23

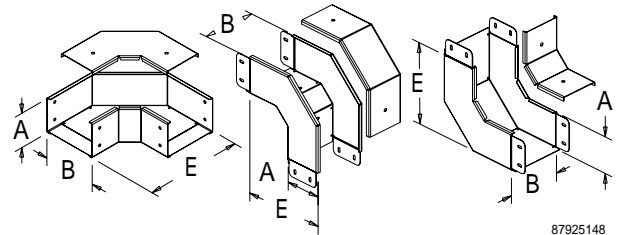

87925148

J hZY1] ZgkZgV. %YZ\gZig'ch'bc'h'gfj gZY#B dYZh1 1] dj i'
iWmXdcCZXi Y'gXiand'Vcdi] ZgZaMl 1 1] dj i j h'e\ VheaXZ#

Catalog Number	AxB in.	AxB mm	Description	E (in.)	E (mm)	K (in.)	K (mm)
CT22EFC90SS	2.00 x 2.00	51 x 51	Top Cover	6.00	152	—	—
CT33EFC90SS	3.00 x 3.00	76 x 76	Top Cover	7.00	178	—	—
CT44EFC90SS	4.00 x 4.00	102 x 102	Top Cover	9.00	229	—	—
CT46EFC90SS	4.00 x 6.00	102 x 152	Top Cover	11.00	279	—	—
CT66EFC90SS	6.00 x 6.00	152 x 152	Top Cover	11.00	279	—	—
CT22EFCNT90SS	2.00 x 2.00	51 x 51	Top Cover without Tabs	6.00	152	—	—
CT33EFCNT90SS	3.00 x 3.00	76 x 76	Top Cover without Tabs	7.00	178	—	—
CT44EFCNT90SS	4.00 x 4.00	102 x 102	Top Cover without Tabs	9.00	229	1.42	36
CT46EFCNT90SS	4.00 x 6.00	102 x 152	Top Cover without Tabs	11.00	279	2.16	55
CT66EFCNT90SS	6.00 x 6.00	152 x 152	Top Cover without Tabs	11.00	279	2.16	55
CT22EIC90SS	2.00 x 2.00	51 x 51	Inside Cover	6.00	152	—	—
CT33EIC90SS	3.00 x 3.00	76 x 76	Inside Cover	7.00	178	—	—
CT44EIC90SS	4.00 x 4.00	102 x 102	Inside Cover	9.00	229	—	—
CT46EIC90SS	4.00 x 6.00	102 x 152	Inside Cover	11.00	279	—	—
CT66EIC90SS	6.00 x 6.00	152 x 152	Inside Cover	11.00	279	—	—
CT22EOC90SS	2.00 x 2.00	51 x 51	Outside Cover	6.00	152	—	—
CT33EOC90SS	3.00 x 3.00	76 x 76	Outside Cover	7.00	178	—	—
CT44EOC90SS	4.00 x 4.00	102 x 102	Outside Cover	9.00	229	—	—
CT46EOC90SS	4.00 x 6.00	102 x 152	Outside Cover	11.00	279	—	—
CT66EOC90SS	6.00 x 6.00	152 x 152	Outside Cover	11.00	279	—	—
CT22PEFC90SS	2.00 x 2.00	51 x 51	Top Cover Perforated	6.00	152	—	—
CT33PEFC90SS	3.00 x 3.00	76 x 76	Top Cover Perforated	7.00	178	—	—
CT44PEFC90SS	4.00 x 4.00	102 x 102	Top Cover Perforated	9.00	229	—	—
CT46PEFC90SS	4.00 x 6.00	102 x 152	Top Cover Perforated	11.00	279	—	—
CT66PEFC90SS	6.00 x 6.00	152 x 152	Top Cover Perforated	11.00	279	—	—

CLEANTRAY 90-DEGREE ELBOWS—TOP COVER SLOPED INWARD



J hZY1] ZgkZgV. %YZ\gZig'ch'bc'h'gfj gZY#B dYZh1 1] dj i'
iWmXdcCZXi Y'gXiand'Vcdi] ZgZaMl 1 1] dj i j h'e\ VheaXZ#

BULLETIN: F23

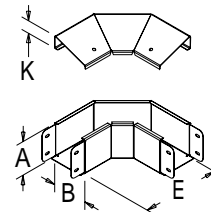

89168777

Catalog Number	AxB in.	AxB mm	Description	E (in.)	E (mm)	K (in.)	K (mm)
CTS33EFC90SS	3.00 x 3.00	76 x 76	Top Cover Sloped Inward	7.00	178	1.06	27
CTS44EFC90SS	4.00 x 4.00	102 x 102	Top Cover Sloped Inward	9.00	229	1.42	36
CTS46EFC90SS	4.00 x 6.00	102 x 152	Top Cover Sloped Inward	11.00	279	2.16	55
CTS66EFC90SS	6.00 x 6.00	152 x 152	Top Cover Sloped Inward	11.00	279	2.16	55
CTS33PEFC90SS	3.00 x 3.00	76 x 76	Top Cover Sloped Inward Perforated	7.00	178	1.06	27
CTS44PEFC90SS	4.00 x 4.00	102 x 102	Top Cover Sloped Inward Perforated	9.00	229	1.42	36
CTS46PEFC90SS	4.00 x 6.00	102 x 152	Top Cover Sloped Inward Perforated	11.00	279	2.16	55
CTS66PEFC90SS	6.00 x 6.00	152 x 152	Top Cover Sloped Inward Perforated	11.00	279	2.16	55

CLEANTRAY 90-DEGREE ELBOWS—PERFORATED WITHOUT TABS



J hZY1] ZgkZgV. %YZ\gZig/ch' dc'h'gfj gZY#
BULLETIN: F23

Catalog Number	AxB in.	AxB mm	E (in.)	E (mm)
CT22PEFCNT90SS	2.00 x 2.00	51 x 51	6.00	152
CT33PEFCNT90SS	3.00 x 3.00	76 x 76	7.00	178
CT44PEFCNT90SS	4.00 x 4.00	102 x 102	9.00	229
CT46PEFCNT90SS	4.00 x 6.00	102 x 152	11.00	279
CT66PEFCNT90SS	6.00 x 6.00	152 x 152	11.00	279

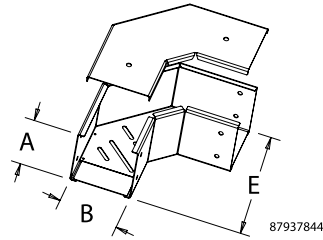

CLEANTRAY 90-DEGREE ELBOWS—TOP COVER SLOPED INWARD WITHOUT TABS



J hZY1] ZgkZgV. %YZ\gZig/ch' dc'h'gfj gZY#
BULLETIN: F23

Catalog Number	AxB in./mm	E in./mm	K in./mm
CTS44EFCNT90SS	4.00 x 4.00	9.00	1.42
	102 x 102	229	36
CTS46EFCNT90SS	4.00 x 6.00	11.00	2.16
	102 x 152	279	55
CTS66EFCNT90SS	6.00 x 6.00	11.00	2.16
	152 x 152	279	55

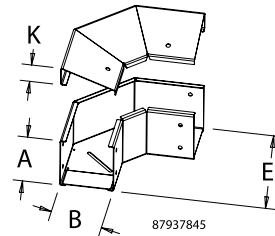

CLEANTRAY 90-DEGREE ELBOWS—TOP COVER SLOPED OUTWARD WITH TABS



J hZY1] ZgkZgV. %YZ\gZig/ch' dc'h'gfj gZY#
BULLETIN: F23

Catalog Number	AxB in./mm	E in./mm	K in./mm
CTS44EFCO90SS	4.00 x 4.00	9.00	1.42
	102 x 102	229	36
CTS46EFCO90SS	4.00 x 6.00	11.00	2.16
	102 x 152	279	55
CTS66EFCO90SS	6.00 x 6.00	11.00	2.16
	152 x 152	279	55

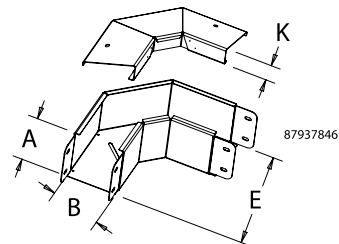

CLEANTRAY 90-DEGREE ELBOWS—TOP COVER SLOPED OUTWARD WITHOUT TABS



J hZY1] ZgkZgV. %YZ\gZig/ch'bc'h'gfj gZY#
BULLETIN: F23

Catalog Number	AxB in./mm	E in./mm	K in./mm
CTS44EFCONT90SS	4.00 x 4.00 102 x 102	9.00 229	1.42 36
CTS46EFCONT90SS	4.00 x 6.00 102 x 152	11.00 279	2.16 55
CTS66EFCONT90SS	6.00 x 6.00 152 x 152	11.00 279	2.16 55

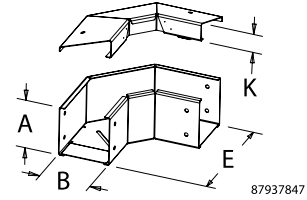

CLEANTRAY 90-DEGREE ELBOWS—INSIDE COVER SLOPED



J hZY1] ZgkZgV. %YZ\gZig/ch'bc'h'gfj gZY#
BULLETIN: F23

Catalog Number	AxB in./mm	E in./mm	K in./mm
CTS44EIC90SS	4.00 x 4.00 102 x 102	9.00 229	1.42 36
CTS46EIC90SS	4.00 x 6.00 102 x 152	11.00 279	2.16 55
CTS66EIC90SS	6.00 x 6.00 152 x 152	11.00 279	2.16 55

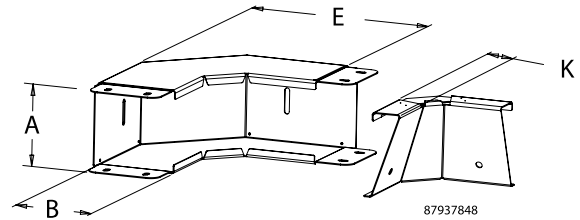

CLEANTRAY 90-DEGREE ELBOWS—OUTSIDE COVER SLOPED



J hZY1] ZgkZgV. %YZ\gZig/ch'bc'h'gfj gZY#
BULLETIN: F23

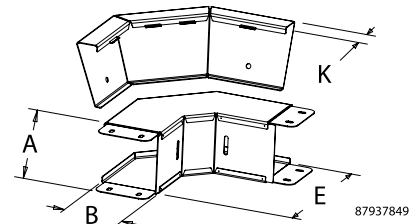

Catalog Number	AxB in./mm	E in./mm	K in./mm
CTS44EOC90SS	4.00 x 4.00 102 x 102	9.00 229	1.42 36
CTS46EOC90SS	4.00 x 6.00 102 x 152	11.00 279	2.16 55
CTS66EOC90SS	6.00 x 6.00 152 x 152	11.00 279	2.16 55

CLEANTRAY 45-DEGREE ELBOWS

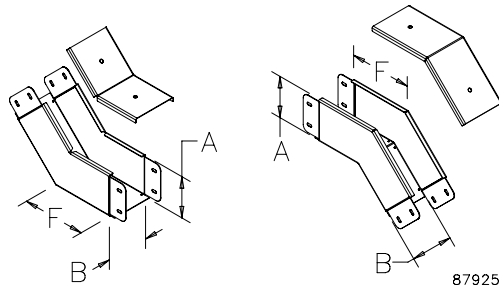

87925149

J hZY1] ZgkZgV) * "YZ\gZigch'dc'h'gfj 'gY#

BULLETIN: F23

Catalog Number	AxB in.	AxB mm	Description	F (in.)	F (mm)
CT22EFC45SS	2.00 x 2.00	51 x 51	Top Cover	4.57	116
CT33EFC45SS	3.00 x 3.00	76 x 76	Top Cover	4.98	127
CT44EFC45SS	4.00 x 4.00	102 x 102	Top Cover	5.96	151
CT46EFC45SS	4.00 x 6.00	102 x 152	Top Cover	6.79	173
CT66EFC45SS	6.00 x 6.00	152 x 152	Top Cover	6.79	173
CT22EIC45SS	2.00 x 2.00	51 x 51	Inside Cover	4.57	116
CT33EIC45SS	3.00 x 3.00	76 x 76	Inside Cover	4.98	127
CT44EIC45SS	4.00 x 4.00	102 x 102	Inside Cover	5.96	151
CT46EIC45SS	4.00 x 6.00	102 x 152	Inside Cover	6.79	173
CT66EIC45SS	6.00 x 6.00	152 x 152	Inside Cover	6.79	173
CT22EOC45SS	2.00 x 2.00	51 x 51	Outside Cover	4.57	116
CT33EOC45SS	3.00 x 3.00	76 x 76	Outside Cover	4.98	127
CT44EOC45SS	4.00 x 4.00	102 x 102	Outside Cover	5.96	151
CT46EOC45SS	4.00 x 6.00	102 x 152	Outside Cover	6.79	173
CT66EOC45SS	6.00 x 6.00	152 x 152	Outside Cover	6.79	173
CT22PEFC45SS	2.00 x 2.00	51 x 51	Top Cover Perforated	4/57	116
CT33PEFC45SS	3.00 x 3.00	76 x 76	Top Cover Perforated	4.98	127
CT44PEFC45SS	4.00 x 4.00	102 x 102	Top Cover Perforated	5.96	151
CT46PEFC45SS	4.00 x 6.00	102 x 152	Top Cover Perforated	6.79	173
CT66PEFC45SS	6.00 x 6.00	152 x 152	Top Cover Perforated	6.79	173

CLEANTRAY 45-DEGREE ELBOWS—TOP COVER SLOPED INWARD BULLETIN: F23

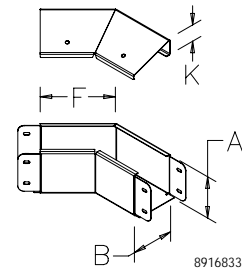

89168333

J hZY1] ZgkZgV) * "YZ\gZigch'dc'h'gfj 'gY#

Catalog Number	AxB in.	AxB mm	Description	F (in.)	F (mm)	K (in.)	K (mm)
CTS33EFC45SS	3.00 x 3.00	76 x 76	Top Cover Sloped Inward	4.98	127	1.06	27
CTS44EFC45SS	4.00 x 4.00	102 x 102	Top Cover Sloped Inward	5.96	151	1.42	36
CTS46EFC45SS	4.00 x 6.00	102 x 152	Top Cover Sloped Inward	6.79	173	2.16	55
CTS66EFC45SS	6.00 x 6.00	152 x 152	Top Cover Sloped Inward	6.79	173	2.16	55
CTS33PEFC45SS	3.00 x 3.00	76 x 76	Top Cover Sloped Inward Perforated	4.98	127	1.06	27
CTS44PEFC45SS	4.00 x 4.00	102 x 102	Top Cover Sloped Inward Perforated	5.96	151	1.42	36
CTS46PEFC45SS	4.00 x 6.00	102 x 152	Top Cover Sloped Inward Perforated	6.79	173	2.16	55
CTS66PEFC45SS	6.00 x 6.00	152 x 152	Top Cover Sloped Inward Perforated	6.79	173	2.16	55

CLEANTRAY 45-DEGREE ELBOWS—TOP COVER SLOPED OUTWARD



J hZY1] ZgkZgV) * "YZ\gZig/ch1'dc'h'gfj 'gZY#
BULLETIN: F23

Catalog Number	AxB in./mm	F in./mm	K in./mm
CTS44EFCO45SS	4.00 x 4.00 102 x 102	5.96 151	1.42 36
CTS46EFCO45SS	4.00 x 6.00 102 x 152	6.79 173	2.16 55
CTS66EFCO45SS	6.00 x 6.00 152 x 152	6.79 173	2.16 55

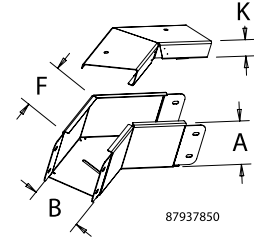

CLEANTRAY 45-DEGREE ELBOWS—INSIDE COVER SLOPED



J hZY1] ZgkZgV) * "YZ\gZig/ch1'dc'h'gfj 'gZY#
BULLETIN: F23

Catalog Number	AxB in./mm	F in./mm	K in./mm
CTS44EIC45SS	4.00 x 4.00 102 x 102	5.96 151	1.42 36
CTS46EIC45SS	4.00 x 6.00 102 x 152	6.79 173	2.16 55
CTS66EIC45SS	6.00 x 6.00 152 x 152	6.79 173	2.16 55

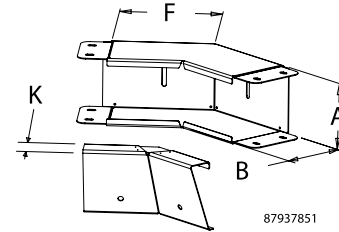

CLEANTRAY 45-DEGREE ELBOWS—OUTSIDE COVER SLOPED



J hZY1] ZgkZgV) * "YZ\gZig/ch1'dc'h'gfj 'gZY#
BULLETIN: F23

Catalog Number	AxB in./mm	F in./mm	K in./mm
CTS44EOC45SS	4.00 x 4.00 102 x 102	5.96 151	1.42 36
CTS46EOC45SS	4.00 x 6.00 102 x 152	6.79 173	2.16 55
CTS66EOC45SS	6.00 x 6.00 152 x 152	6.79 173	2.16 55

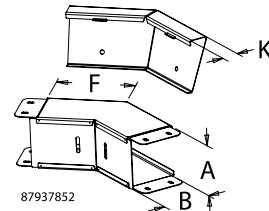

CLEANTRAY VARIABLE-ANGLE ELBOW FITTING



Catalog Number	AxB in.	AxB mm
CT22VSS	2.00 x 2.00	51 x 51
CT33VSS	3.00 x 3.00	76 x 76
CT44VSS	4.00 x 4.00	102 x 102
CT46VSS	4.00 x 6.00	102 x 152
CT66VSS	6.00 x 6.00	152 x 152

6Yj hiWVZ [g]b %ad: %YZ\gZ#Hb ea ZhVcYhMkZh` Za`
 'ciZ\g] 'dcVcY`chiVaM 'dc]b Z#

BULLETIN: F23

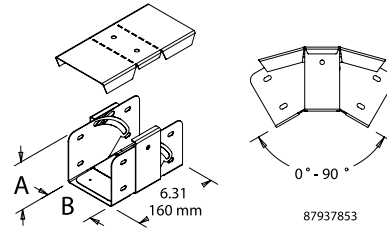

CLEANTRAY 90-DEGREE TEE



BULLETIN: F23

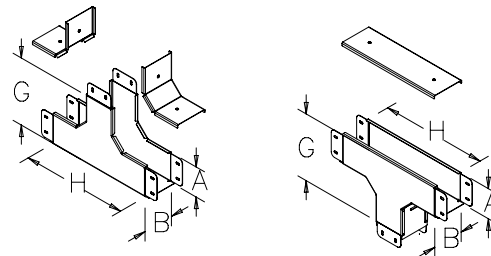

6kVAVZ1 1] 'dgi 1] dj i 'eZjdgM 'dch'c] gZZ\XdkZgdei 'dch'idei`
 'chYZVcY'dj ihYZ#] hZY1]ZgkZg]l d: %YZ\gZ]g]ch' 'dchVg`
 g]f j gY#

87925153

Catalog Number	AxB in.	AxB mm	Description	G (in.)	G (mm)	H (in.)	H (mm)
CT22TFCSS	2.00 x 2.00	51 x 51	Top Cover	3.00	152	10.00	254
CT33TFCSS	3.00 x 3.00	76 x 76	Top Cover	9.00	229	14.00	356
CT44TFCSS	4.00 x 4.00	102 x 102	Top Cover	7.00	178	11.00	279
CT46TFCSS	4.00 x 6.00	102 x 152	Top Cover	11.00	279	16.00	406
CT66TFCSS	6.00 x 6.00	152 x 152	Top Cover	11.00	279	16.00	406
CT33TICSS	3.00 x 3.00	76 x 76	Inside Cover	7.00	178	11.00	279
CT44TICSS	4.00 x 4.00	102 x 102	Inside Cover	9.00	229	14.00	356
CT46TICSS	4.00 x 6.00	102 x 152	Inside Cover	11.00	279	16.00	406
CT66TICSS	6.00 x 6.00	152 x 152	Inside Cover	11.00	279	16.00	406
CT22TOCSS	2.00 x 2.00	51 x 51	Outside Cover	6.00	152	10.00	254
CT33TOCSS	3.00 x 3.00	76 x 76	Outside Cover	7.00	178	11.00	279
CT44TOCSS	4.00 x 4.00	102 x 102	Outside Cover	9.00	229	14.00	356
CT46TOCSS	4.00 x 6.00	102 x 152	Outside Cover	11.00	279	16.00	406
CT66TOCSS	6.00 x 6.00	152 x 152	Outside Cover	11.00	279	16.00	406
CT22PTFCSS	2.00 x 2.00	51 x 51	Top Cover Perforated	6.00	152	10.00	254
CT33PTFCSS	3.00 x 3.00	76 x 76	Top Cover Perforated	7.00	178	11.00	279
CT44PTFCSS	4.00 x 4.00	102 x 102	Top Cover Perforated	9.00	229	14.00	356
CT46PTFCSS	4.00 x 6.00	102 x 152	Top Cover Perforated	11.00	279	16.00	406
CT66PTFCSS	6.00 x 6.00	152 x 152	Top Cover Perforated	11.00	279	16.00	406

CLEANTRAY 90-DEGREE TEE—TOP COVER SLOPED INWARD

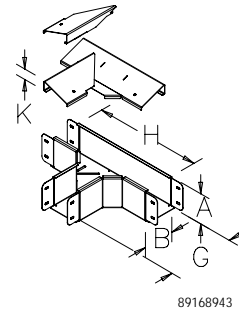

BULLETIN: F23

Catalog Number	AxB in.	AxB mm	Description	G (in.)	G (mm)	H (in.)	H (mm)	K (in.)	K (mm)
CTS33TFCSS	3.00 x 3.00	76 x 76	Top Cover Sloped	7.00	178	11.00	279	1.06	27
CTS44TFCSS	4.00 x 4.00	102 x 102	Top Cover Sloped	9.00	229	14.00	356	1.42	36
CTS46TFCSS	4.00 x 6.00	102 x 152	Top Cover Sloped	11.00	279	16.00	406	2.16	55
CTS66TFCSS	6.00 x 6.00	152 x 152	Top Cover Sloped	11.00	279	16.00	406	2.16	55
CTS33PTFCSS	3.00 x 3.00	76 x 76	Top Cover Sloped Perforated	7.00	178	11.00	279	1.06	27
CTS44PTFCSS	4.00 x 4.00	102 x 102	Top Cover Sloped Perforated	9.00	229	14.00	356	1.42	36
CTS46PTFCSS	4.00 x 6.00	102 x 152	Top Cover Sloped Perforated	11.00	279	16.00	406	2.16	55
CTS66PTFCSS	6.00 x 6.00	152 x 152	Top Cover Sloped Perforated	11.00	279	16.00	406	2.16	55

CLEANTRAY 90-DEGREE TEE—TOP COVER SLOPED OUTWARD

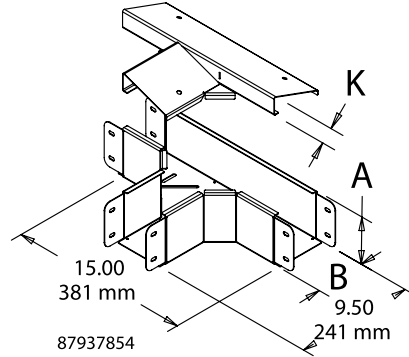

JhZY1 JZgkZgjl d: %YZ\gZZ1g\chf\chVg'gfj gZY#

BULLETIN: F23

Catalog Number	AxB in.	AxB mm	K (in.)	K (mm)
CTS44TFCOSS	4.00 x 4.00	102 x 102	1.42	36
CTS46TFCOSS	4.00 x 6.00	102 x 152	2.16	55
CTS66TFCOSS	6.00 x 6.00	152 x 152	2.16	55

CLEANTRAY 90-DEGREE TEE—INSIDE COVER SLOPED



Catalog Number	AxB in.	AxB mm	K (in.)	K (mm)
CTS44TICSS	4.00 x 4.00	102 x 102	1.42	36
CTS46TICSS	4.00 x 6.00	102 x 152	2.16	55
CTS66TICSS	6.00 x 6.00	152 x 152	2.16	55

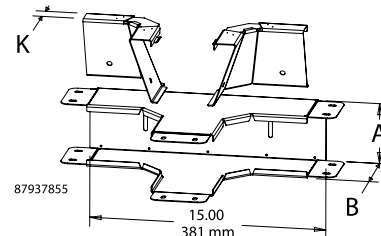

JhZY1 JZgkZgjl d: %YZ\gZZ1g\chf\chVg'gfj gZY#

BULLETIN: F23

CLEANTRAY 90-DEGREE TEE—OUTSIDE COVER SLOPED



J hZY1] ZgZgi d. %VZgZi gchf chVgZgfj gZY#

BULLETIN: F23

Catalog Number	AxB in.	AxB mm	G (in.)	G (mm)	K (in.)	K (mm)
CTS44TOCSS	4.00 x 4.00	102 x 102	9.00	229	1.42	36
CTS46TOCSS	4.00 x 6.00	102 x 152	11.00	279	2.16	55
CTS66TOCSS	6.00 x 6.00	152 x 152	11.00	279	2.16	55

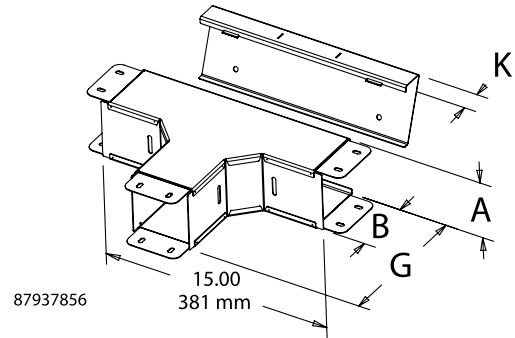

CLEANTRAY CROSS



6kVAVZ1 1] dgj 1] dj i eZgdgM ch#J hZY1] ZgZi] ZgZVgZdj g Vg/cX] Zh#

BULLETIN: F23

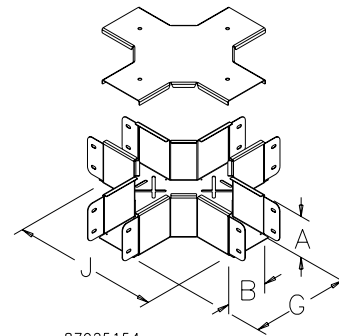

Catalog Number	AxB in.	AxB mm	Description	G (in.)	G (mm)	J (in.)	J (mm)
CT22CSS	2.00 x 2.00	51 x 51	Standard	6.00	152	10	254
CT33CSS	3.00 x 3.00	76 x 76	Standard	7.00	178	11.00	279
CT44CSS	4.00 x 4.00	102 x 102	Standard	9.00	229	14.00	356
CT46CSS	4.00 x 6.00	102 x 152	Standard	11.00	279	16.00	406
CT66CSS	6.00 x 6.00	152 x 152	Standard	11.00	279	16.00	406
CT22PCSS	2.00 x 2.00	51 x 51	Perforated	6.00	152	10.00	254
CT33PCSS	3.00 x 3.00	76 x 76	Perforated	7.00	178	11.00	279
CT44PCSS	4.00 x 4.00	102 x 102	Perforated	9.00	229	14.00	356
CT46PCSS	4.00 x 6.00	102 x 152	Perforated	11.00	279	16.00	406
CT66PCSS	6.00 x 6.00	152 x 152	Perforated	11.00	279	16.00	406

CLEANTRAY CROSS-SLOPED TOP

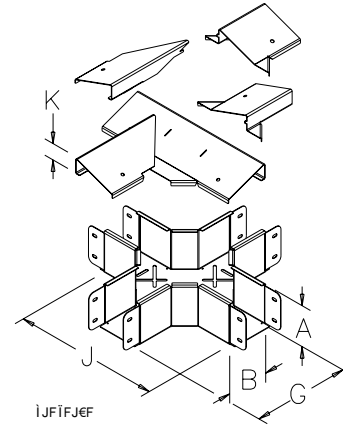

6kVAVZ1 4] dgi 1] dj i eZgdM dch#J hZY1] Zg'i] Zg' VgZ [dj g Vg/cX] Zh#@1'cXg YZhVdi] z[i VcY'g\] i hadeZY'XdkZgnid XgVIZ' VcnXdc \j g/i dlc#

BULLETIN: F23

Catalog Number	AxB in./mm	Description	G in./mm	J in./mm	K in./mm
CTS33CSS	3.00 x 3.00 76 x 76	Sloped Top	7.00 178	11.00 279	1.06 27
CT44CSS	4.00 x 4.00 102 x 102	Sloped Top	9.00 229	14.00 356	1.42 36
CTS46CSS	4.00 x 6.00 102 x 152	Sloped Top	11.00 279	16.00 406	2.16 55
CTS66CSS	6.00 x 6.00 152 x 152	Sloped Top	11.00 279	16.00 406	2.16 55
CTS33PCSS	3.00 x 3.00 76 x 76	Perforated Sloped Top	7.00 178	11.00 279	1.06 27
CTS44PCSS	4.00 x 4.00 102 x 102	Perforated Sloped Top	9.00 229	14.00 356	1.42 36
CTS46PCSS	4.00 x 6.00 102 x 152	Perforated Sloped Top	11.00 279	16.00 406	2.16 55
CTS66PCSS	6.00 x 6.00 152 x 152	Perforated Sloped Top	11.00 279	16.00 406	2.16 55

CLEANTRAY DIVIDER 90-DEGREE TEE



Catalog Number	Fits Cable		Description	L (in.)	L (mm)	M (in.)	M (mm)
	Tray Size						
CT33DTFCSS	3 x 3	Top Cover	2.13	54	—	—	
CT44DTFCSS	4 x 4	Top Cover	3.13	79	—	—	
CT46DTFCSS	4 x 6	Top Cover	3.13	79	—	—	
CT66DTFCSS	6 x 6	Top Cover	5.13	130	—	—	
CT33DTICSS	3 x 3	Inside Cover	2.13	54	1.75	45	
CT44DTICSS	4 x 4	Inside Cover	3.13	79	2.75	70	
CT66DTICSS	6 x 6	Inside Cover	5.13	130	4.75	121	
CT33DTCSS	3 x 3	Outside Cover	2.13	54	2.58	66	
CT44DTCSS	4 x 4	Outside Cover	3.13	79	3.70	94	
CT66DTCSS	6 x 6	Outside Cover	5.13	130	5.70	145	

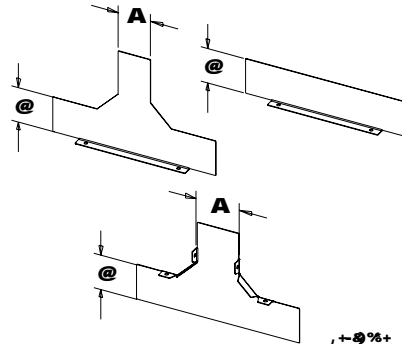

JhZYidY'k'YZV. %YZ\gZiZZ'cidil d'hZXi dlc#

BULLETIN: F23

CLEANTRAY DIVIDER 90-DEGREE ELBOW



J hZYidYkYZV. %YZ\gZZaMl 'cidil d'hZXi'dch#
 BULLETIN: F23

Catalog Number	Description	Fits Cable		
		Tray Size	L (in.)	L (mm)
CT33DEFC90SS	Top Cover	3 x 3	2.13	54
CT44DEFC90SS	Top Cover	4 x 4	3.13	79
CT46DEFC90SS	Top Cover	4 x 6	3.13	79
CT66DEFC90SS	Top Cover	6 x 6	5.13	130
CT33DEIC90SS	Inside Cover	3 x 3	2.13	54
CT44DEIC90SS	Inside Cover	4 x 4, 4 x 6	3.13	79
CT66DEIC90SS	Inside Cover	6 x 6	5.13	130
CT33DEOC90SS	Outside Cover	3 x 3	2.13	54
CT44DEOC90SS	Outside Cover	4 x 4, 4 x 6	3.13	79
CT66DEOC90SS	Outside Cover	6 x 6	5.13	130

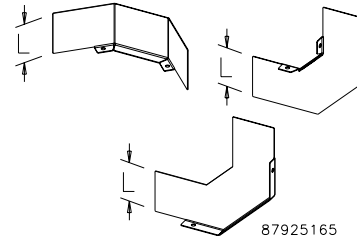

CLEANTRAY DIVIDER 45-DEGREE ELBOW



J hZYidYkYZV) *'YZ\gZZaMl 'cidil d'hZXi'dch#
 BULLETIN: F23

Catalog Number	Description	Fits Cable		
		Tray Size	L (in.)	L (mm)
CT33DEFC45SS	Top Cover	3 x 3	2.13	54
CT44DEFC45SS	Top Cover	4 x 4	3.13	79
CT46DEFC45SS	Top Cover	4 x 6	3.13	79
CT66DEFC45SS	Top Cover	6 x 6	5.13	130
CT33DEIC45SS	Inside Cover	3 x 3	2.13	54
CT44DEIC45SS	Inside Cover	4 x 4, 4 x 6	3.13	79
CT66DEIC45SS	Inside Cover	6 x 6	5.13	130
CT33DEOC45SS	Outside Cover	3 x 3	2.13	54
CT44DEOC45SS	Outside Cover	4 x 4, 4 x 6	3.13	79
CT66DEOC45SS	Outside Cover	6 x 6	5.13	130

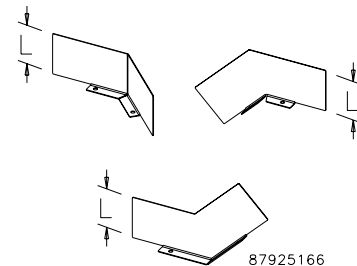

CLEANTRAY U-CONNECTOR



J hZYidXdccZXi il d'hig/\]i hZXi'dch#
 BULLETIN: F23

Catalog Number	AxB in./mm
CT22UCSS	2.00 x 2.00 51 x 51
CT33UCSS	3.00 x 3.00 76 x 76
CT44UCSS	4.00 x 4.00 102 x 102
CT46UCSS	4.00 x 6.00 102 x 152
CT66UCSS	6.00 x 6.00 152 x 152

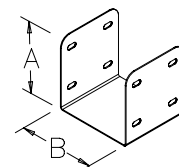

CLEANTRAY CLOSURE PLATE



8ahZhi] ZZcY'd[VXWZ'ig/nhZi'bc'dgg c#
BULLETIN: F23

Catalog Number	AxB in.	AxB mm	Description
CT22CPSS	2.00 x 2.00	51 x 51	Standard
CT33CPSS	3.00 x 3.00	76 x 76	Standard
CT44CPSS	4.00 x 4.00	102 x 102	Standard
CT46CPSS	4.00 x 6.00	102 x 152	Standard
CT66CPSS	6.00 x 6.00	152 x 152	Standard

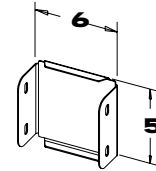

, +.0%*

CLEANTRAY CLOSURE PLATE—SLOPED TOP



Catalog Number	AxB in.	AxB mm	Description	K (in.)	K (mm)
CTS44CPRSS	4.00 x 4.00	102 x 102	Sloped Right	1.42	36
CTS44CPLSS	4.00 x 4.00	102 x 102	Sloped Left	1.42	36
CTS46CPRSS	4.00 x 6.00	102 x 152	Sloped Right	2.16	55
CTS46CPLSS	4.00 x 6.00	102 x 152	Sloped Left	2.16	55
CTS66CPRSS	6.00 x 6.00	152 x 152	Sloped Right	2.16	55
CTS66CPLSS	6.00 x 6.00	152 x 152	Sloped Left	2.16	55

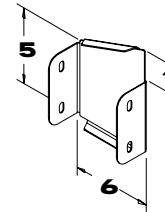

, -.0%+K

8ahZhi] ZZcY'd[VXWZ'ig/nhZi'bc'dgg c#z[i'haleZi] dl c#
BULLETIN: F23

Catalog Number	AxB in.	AxB mm	Description	K (in.)	K (mm)
CTS33CPRSS	3.00 x 3.00	76 x 76	Sloped Right	1.06	27
CTS33CPLSS	3.00 x 3.00	76 x 76	Sloped Left	1.06	27

CLEANTRAY ENCLOSURE ADAPTER



Catalog Number	AxB in./mm
CT22AESS	2.00 x 2.00 51 x 51
CT33AESS	3.00 x 3.00 76 x 76
CT44AESS	4.00 x 4.00 102 x 102
CT46AESS	4.00 x 6.00 102 x 152
CT66AESS	6.00 x 6.00 152 x 152

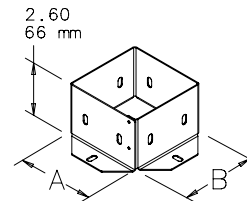

87925157

6adl hi] ZXWZ'ig/nidV'hZj g'anXdccZiZY'id'Ve'ZcXahj g#
BULLETIN: F23

CLEANTRAY STRAIGHT SECTION SPLICE



JhZYidXdccZXil d° ii c\h1 1j 1WM#
 BULLETIN: F23

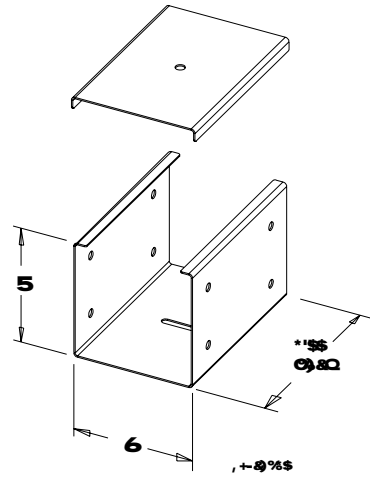

Catalog Number	AxB in.	AxB mm	Description
CT22SPSS	2.00 x 2.00	51 x 51	Standard
CT33SPSS	3.00 x 3.00	76 x 76	Standard
CT44SPSS	4.00 x 4.00	102 x 102	Standard
CT46SPSS	4.00 x 6.00	102 x 152	Standard
CT66SPSS	6.00 x 6.00	152 x 152	Standard
CT22PSPSS	2.00 x 2.00	51 x 51	Perforated
CT33PSPSS	3.00 x 3.00	76 x 76	Perforated
CT44PSPSS	4.00 x 4.00	102 x 102	Perforated
CT46PSPSS	4.00 x 6.00	102 x 152	Perforated
CT66PSPSS	6.00 x 6.00	152 x 152	Perforated

CLEANTRAY STRAIGHT SECTION SPLICE—SLOPED TOP



JhZYidXdccZXil d° ii c\h1 1j 1WM#
 BULLETIN: F23

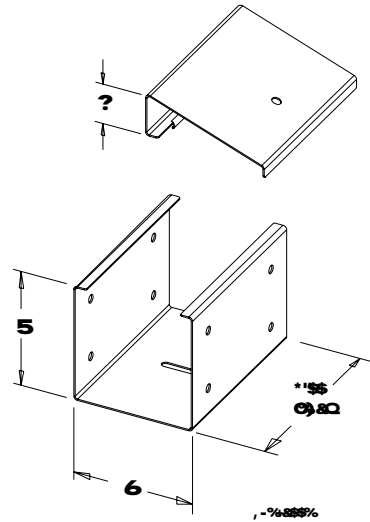

Catalog Number	AxB in.	AxB mm	Description	K (in.)	K (mm)
CTS33SPSS	3.00 x 3.00	76 x 76	Sloped Top	1.06	27
CTS44SPSS	4.00 x 4.00	102 x 102	Sloped Top	1.42	36
CTS46SPSS	4.00 x 6.00	102 x 152	Sloped Top	2.16	55
CTS66SPSS	6.00 x 6.00	152 x 152	Sloped Top	2.16	55
CTS33PSPSS	3.00 x 3.00	76 x 76	Sloped Top, Perforated	1.06	27
CTS44PSPSS	4.00 x 4.00	102 x 102	Sloped Top, Perforated	1.42	36
CTS46PSPSS	4.00 x 6.00	102 x 152	Sloped Top, Perforated	2.16	55
CTS66PSPSS	6.00 x 6.00	152 x 152	Sloped Top, Perforated	2.16	55

CLEANTRAY REDUCER



J hZYid'gYj XZidVhb VazZghbZ XWZidgH#

BULLETIN: F23

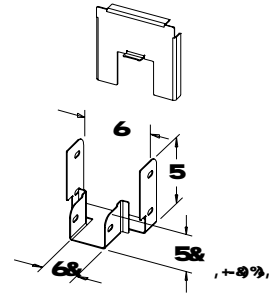

Catalog Number	AxB in.	AxB mm	Description	A2 (in.)	A2 (mm)	B2 (in.)	B2 (mm)
CT3322RSS	3.00 x 3.00	76 x 76	3 x 3 2 x 2 Standard	2.00	51	2.00	51
CT4433RSS	4.00 x 4.00	102 x 102	4 x 4 3 x 3 Standard	3.00	76	3.00	76
CT4422RSS	4.00 x 4.00	102 x 102	4 x 4 2 x 2 Standard	2.00	51	2.00	51
CT4644RSS	4.00 x 6.00	102 x 152	4 x 6 4 x 4 Standard	4.00	102	4.00	102
CT4633RSS	4.00 x 6.00	102 x 152	4 x 6 3 x 3 Standard	3.00	76	3.00	76
CT6622RSS	6.00 x 6.00	152 x 152	6 x 6 2 x 2 Standard	2.00	51	2.00	51
CT6646RSS	6.00 x 6.00	152 x 152	6 x 6 4 x 6 Standard	4.00	102	6.00	152
CT6644RSS	6.00 x 6.00	152 x 152	6 x 6 4 x 4 Standard	4.00	102	4.00	102
CT6633RSS	6.00 x 6.00	152 x 152	6 x 6 3 x 3 Standard	3.00	76	3.00	76

CLEANTRAY REDUCER—SLOPED TOP

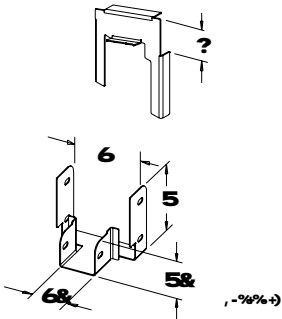

J hZYid'gYj XZidVhb VazZghbZ XWZidgH# | i haleZ'hj dl d#

BULLETIN: F23

Catalog Number	AxB in.	AxB mm	Description	A2 (in.)	A2 (mm)	B2 (in.)	B2 (mm)	K (in.)	K (mm)
CTS4433RRSS	4.00 x 4.00	102 x 102	4x4 3x3 Sloped Right	3.00	76	3.00	76	1.42	36
CTS4433RLSS	4.00 x 4.00	102 x 102	4x4 3x3 Sloped Left	3.00	76	3.00	76	1.42	36
CTS4633RRSS	4.00 x 6.00	102 x 152	4x6 3x3 Sloped Right	3.00	76	3.00	76	2.16	55
CTS4633RLSS	4.00 x 6.00	102 x 152	4x6 3x3 Sloped Left	3.00	76	3.00	76	2.16	55
CTS4644RRSS	4.00 x 6.00	102 x 152	4x6 4x4 Sloped Right	4.00	102	4.00	102	2.16	55
CTS4644RLSS	4.00 x 6.00	102 x 152	4x6 4x4 Sloped Left	4.00	102	4.00	102	2.16	55
CTS6633RRSS	6.00 x 6.00	152 x 152	6x6 3x3 Sloped Right	3.00	76	3.00	76	2.16	55
CTS6633RLSS	6.00 x 6.00	152 x 152	6x6 3x3 Sloped Left	3.00	76	3.00	76	2.16	55
CTS6644RRSS	6.00 x 6.00	152 x 152	6x6 4x4 Sloped Right	4.00	102	4.00	102	2.16	55
CTS6644RLSS	6.00 x 6.00	152 x 152	6x6 4x4 Sloped Left	4.00	102	4.00	102	2.16	55
CTS6646RRSS	6.00 x 6.00	152 x 152	6x6 4x6 Sloped Right	4.00	102	4.00	102	2.16	55
CTS6646LSS	6.00 x 6.00	152 x 152	6x6 4x6 Sloped Left	4.00	102	4.00	102	2.16	55

CLEANTRAY CABLE EXIT COVER



8dkZghXWZhi] Vi Zm'i] Z'hYZ'd[i] Z'XWZ'ig/n#L 'adXdkZgV
 ~Zn] daz'dghati j hZY'ideVhhi] Z'XWZ'i] gij \] #

BULLETIN: F23

Catalog Number	T in./mm
CT2233CEC	1.50 38
CT4466CEC	3.00 76

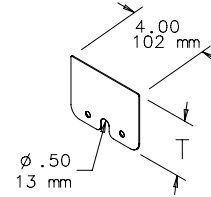

87925159

CLEANTRAY DIVIDER STRAIGHT SECTION SPLICE



J hZY'idYk'YZVhig/\] i hZXi'dc'headZ'cidil d'hZXi'dch#
 BULLETIN: F23

Catalog Number	H in./mm	L in./mm	Fits Cable Tray Size
CT33DSPSS	2.13 54	6.00 152	3x3
CT44DSPSS	3.13 79	6.00 152	4x4, 4x6
CT66DSPSS	5.13 130	6.00 152	6x6

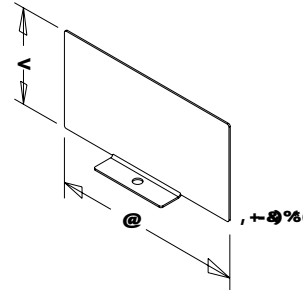

CLEANTRAY TRANSITION COVER



I g]chf'dchTgib VhaleZY'idhiVcYVg'XWZ'ig/n#kv'AWZ'i f] °
 g\]i"VcY'z[i"] VcY'haleZ#L 'ai i] Z'HeaX'ldgZghZeVgM'Zat'dg
 Vcn]]Zg'dcVhig/\] i hZXi'dc'ig]chf'dc'XdkZghaleZY'id' Vi'z[i]"
]VcY'h]dl c'c'YgM 'c\#

BULLETIN: F23

Catalog Number	Description	Fits Cable Tray Size	B in./mm	K in./mm
CTS33TCRSS	Transition Cover Sloped to Flat Right Hand	3 x 3	3.00 76	1.06 27
CTS33TCLSS	Transition Cover Sloped to Flat Left Hand	3 x 3	3.00 76	1.06 27
CTS44TCRSS	Transition Cover Sloped to Flat Right Hand	4 x 4	4.00 102	1.42 36
CTS44TCLSS	Transition Cover Sloped to Flat Left Hand	4 x 4	4.00 102	1.42 36
CTS46TCRSS	Transition Cover Sloped to Flat Right Hand	4 x 6, 6 x 6	6.00 152	2.16 55
CTS46TCLSS	Transition Cover Sloped to Flat Left Hand	4 x 6, 6 x 6	6.00 152	2.16 55

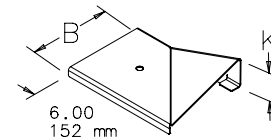

87925161

CLEANTRAY SIDE COUPLING



J hZYidXdccZXi hV\ i hZi bchdg ii c\hid i] ZhYZd[VXWZ[®] ig hñg c#6Xj idj i l aVZgfj gYci] ZhYZd[i] ZXWZig hñg

BULLETIN: F23

Catalog Number	AxB in.	AxB mm
CT22SCSS	2.00 x 2.00	51 x 51
CT33SCSS	3.00 x 3.00	76 x 76
CT44SCSS	4.00 x 4.00	102 x 102
CT46SCSS	4.00 x 6.00	102 x 152
CT66SCSS	6.00 x 6.00	152 x 152

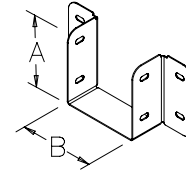

87925162

CLEANTRAY FASTENER PACKAGE

89 " %hVcZhhiZZa[VhiZcZhg hZYidXdccZXi XWZig hñg components.

BULLETIN: F23

Catalog Number	Screws	Nuts
CT1420SS	100	100

CLEANTRAY HANGER BRACKET

J hZYidhj eedg VXWZig hñg c# %eZgeVX VZ#

BULLETIN: F23

Catalog Number	Fits Cable Tray Size	M in./mm
CT22HB	2x2	3.58 91
CT33HB	3x3	4.58 116
CT44HB	4x4	5.58 142
CT66HB	6x6	7.58 193

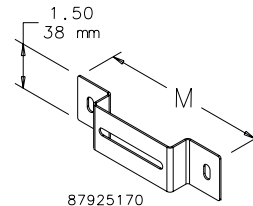

87925170

CLEANTRAY L-BRACKET

J hZYidhj eedg VXWZig hñg c#8VcVZb dj ciZYidVKZg XVá UNISTRUT[®] X] VccZa# %eZgeVX VZ#

J C#Hl G] hVg\ hZgYigVZb Vg d[J cñig i 8dgedM dc#

BULLETIN: F23

Catalog Number	AxB in./mm	Fits Cable Tray Size	N in./mm	P in./mm
CT22LB	2.00 x 2.00	2x2	3.00	3.64
	51 x 51		76	92
CT33LB	3.00 x 3.00	3x3	4.00	4.64
	76 x 76		102	118
CT44LB	4.00 x 4.00	4x4	5.00	5.64
	102 x 102		127	143
CT66LB	6.00 x 6.00	6x6	7.64	7.64
	152 x 152		194	194

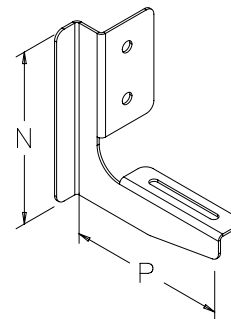

87925169

CLEANTRAY WALL BRACKET

9 WIH XS WYTTSVX E GEFPI XVEJ VYR TIV TEGOEKI
 BULLETIN: F23

Catalog Number	AxB in./mm	Fits Cable Tray Size	R in./mm	S in./mm
CT22WB	2.00 x 2.00 51 x 51	2 x	1.55 39	2.25 57
CT33WB	3.00 x 3.00 76 x 76	3 x 3	2.55 65	3.25 83
CT44WB	4.00 x 4.00 102 x 102	4 x 4	3.55 90	4.25 108
CT66WB	6.00 x 6.00 152 x 152	6 x 6	5.55 141	6.25 159

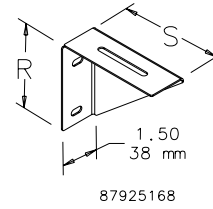

CLEANTRAY LATCH HARDWARE KITS

BULLETIN: F23

Catalog Number	Use with Cable Tray Size
CTLCHSS	2 x 2, 4 x 6, 6 x 6
CTLCH3SS	3 x 3
CTLCH4SS	4 x 4
CTSLCHSS	Sloped