



1492-J Terminal Blocks
1492-J Bornes
1492-J Reihenklemmen
1492-J Morsetti
1492-J Tablillas terminales

USE COPPER WIRE ONLY
UTILISER SEULEMENT DU FIL DE CUIVRE
NUR KUPFERDRAHT VERWENDEN
SOLO USARE FILO DI RAME
SOLO USAR ALAMBRE DE COBRE



ATTENTION: To prevent electrical shock, disconnect from power source before installing or servicing.

ATTENTION: Avant le montage et la mise en service, couper l'alimentation secteur pour éviter toute décharges.

ACHTUNG: Vor Installations- oder Servicearbeiten Stromversorgung unterbrechen, um Electroshocks zu vermeiden.

ATTENZIONE: Per prevenire infortuni, togliere tensione prima dell'installazione o manutenzione.

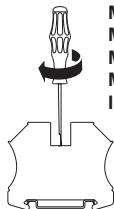
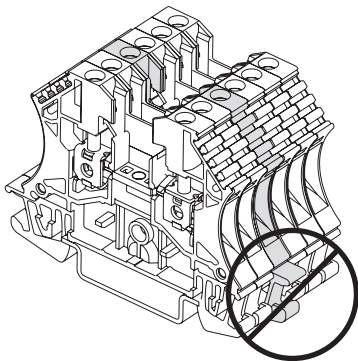

Mount
Monter
Montieren
Montare
Instalar

CAT

1492-J4M	0.5 - 0.8 Nm (4.4 - 7.1 lb-in)
1492-JG2Q	0.4 - 0.6 Nm (3.5 - 5.3 lb-in)
1492-JG3	0.4 - 0.7 Nm (3.5 - 6.2 lb-in)
1492-JG3TW	0.4 - 0.6 Nm (3.5 - 5.3 lb-in)
1492-JG4	0.5 - 0.8 Nm (4.4 - 7.1 lb-in)
1492-JG6	0.5 - 1.0 Nm (4.4 - 8.9 lb-in)
1492-JG10	0.5 - 1.0 Nm (4.4 - 8.9 lb-in)
1492-JG16	1.2 - 2.4 Nm (10.6 - 21.2 lb-in)
1492-JG35	1.2 - 2.4 Nm (10.6 - 21.2 lb-in)
1492-JG50	2.0 - 4.0 Nm (17.7 - 35.4 lb-in)
1492-JG70	2.0 - 4.0 Nm (17.7 - 35.4 lb-in)
1492-JG120	2.0 - 4.0 Nm (17.7 - 35.4 lb-in)
1492-J3	0.5 - 0.8 Nm (4.4 - 7.1 lb-in)
1492-J4	1.0 Nm (9.0 lb-in)
1492-J6	1.6 Nm (14.2 lb-in)
1492-J10	2.3 Nm (20.4 lb-in)
1492-J16	4.0 Nm (35.0 lb-in)
1492-J35	5.8 Nm (51.0 lb-in)
1492-J50	3.6 Nm (31.5 lb-in)
1492-J70	9.8 Nm (87.0 lb-in)
1492-J120	16.0 Nm (141.6 lb-in)

Rockwell Automation
1201 South Second Street
Milwaukee, WI 53204
USA

PN 41063-167-01
DIR 41063-167 (Version 07)
Publication 1492-IN186G-EN-E
4295980000
Printed in Germany

**Rockwell
Automation**